



SUBMITTAL DATA

UNIX Ultra 18 Seer 36KBTU

Model: TUD36-R32AHEDU/ TU36-R32WEDU

Job Name

Purchaser

Submitted to

Unit Designation

Location

Date

Engineer

For

Schedule No.

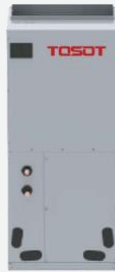

TUD36-R32AHEDU



TU36-R32WEDU

GENERAL FEATURES:

- High Efficiency DC Inverter Technology
- 24VAC Thermostat Compatible
- Zero Lot Line Design
- 8 Speed Fan Motor
- Matched with Tosot Indoor Units
- Designed for New Construction or Replacement Market
- Compact and Quiet, as low as 56 dB(A) Side Discharge outdoor unit
- Cooling down to -15°C (5°F)
- Heating down to -30°C (-22°F)
- Coil (Outdoor) Copper Tube/Aluminum Fin with Anti-Corrosion
- Coil Coating (Gold Colored Fin - 1500Hr Salt Spray Rating)
- Coil (Indoor) Copper Tube/Aluminum Fin with Anti-Corrosion
- Coil Coating (Blue Colored Fin - 500Hr Salt Spray Rating)



SPECIFICATIONS & FUNCTIONS:

Air Handler		TUD36-R32AHEDU
Power Supply	V~/Phases/Hz	208~230/1/60
Air Flow Volume	CFM	1000
External Static Pressure	W.C.	0.5
External Static Pressure Range	W.C.	0~1
Sound Pressure Level	dB	51
Rated Voltage	V	208/230
Rated Frequency	Hz	60
Phases	-	1
Fuse Current	A	3.15
Circuit Breaker	A	15
Output of Heater	W	6000/9000/12000
MOCP	A	15
Motor Full Load Amp(FLA)	A	3.20
Fan Motor Drive Type	-	Direct-driven
Fan Motor Speed	rpm	1010
Fan Motor Power Output	HP	1/2
Evaporator Material	-	Inner groove copper tube-Aluminum fin
Evaporator Face Area	sq.ft	4.09
Evaporator Pipe Diameter	inch	0.28
Evaporator Number of Rows	-	4
Evaporator Tube Pitch×Row Pitch	inch	0.75×0.50
Evaporator Fin Pitch	inch	0.055
Evaporator Number of Circuits	-	12
Evaporator L×H×W	inch	16.3×18×2
Evaporator Max. Allowable Pressure	MPa	12.7
Air Filter	-	Metal
Air Filter Size L×W/NO.	inch	19.3×20.3/1
Air Filter Size (Thickness)	inch	0.6
Drainage Connection Size	inch	φ1×0.05
Cooling Temperature Range	°F	64.4~89.6
Heating Temperature Range	°F	50~80.6
Refrigerant	-	R32
Dimension of Outline(W×D×H)	inch	21.26×21.26×48.19
Dimension of Package(L×W×H)	inch	25.98×23.74×50.98
Net Weight	lbs	163.1
Gross Weight	lbs	178.6

Product Model		TU36-R32WEDU
Power Supply	VAC/Phase/Hz	208~230/1/60
Cooling Capacity	Btu/h	34000
Heating Capacity	Btu/h	34000
EER	(Btu/h)/W	12
COP	(Btu/h)/W	10.92
SEER	-	18
HSPF	-	10.0
Air Flow Volume	CFM	3176
Sound Pressure Level	dB(A)	52
MOCP	A	30
MCA	A	27.7
Compressor Model	-	QXFT-F310zN450B
Compressor Type	-	Inverter Rotary
Compressor Refrigerant Oil Type	-	FW68DA(FW68L)
Compressor Refrigerant Oil Charge Volume	L	1.12
Condenser Material	-	Inner Groove Copper Tube-Aluminum Fin
Condenser Face Area	sq.ft	9.94
Condenser Pipe Diameter	inch	φ0.31
Condenser Number of Rows	-	2
Condenser Tube Pitch(a)×Row Pitch(b)	inch	0.87×0.75
Condenser Fin Pitch	inch	0.055
Condenser Fins per Inch (FPI)	-	18
Condenser Number of Circuits	-	8
Condenser L×H×W	inch	30.1×36.4×1.5
Cooling Temperature Range	°F	5~129.2
Heating Temperature Range	°F	-22~75.2
Defrosting Method	-	Automatic Defrosting
Refrigerant Charge-R32	oz	102.3
Dimension of Outline(W×D×H)	inch	39×14.6×37.8
Dimension of Package(L×W×H)	inch	45.4×18.8×43.7
Net Weight	lbs	187.4
Gross Weight	lbs	211.6
Connection Pipe Length	ft	24.6
Not Additional Gas Connection Pipe Length	ft	31.2
Connection Pipe Gas Additional Charge	oz/ft	0.323
Line Set Size (Liquid - Gas)	inch	3/8"-3/4"
Connection Pipe Max. Distance H×L	ft	49.2×98.4

FAN PERFORMANCE

Static Pressure (Inches W.C.)	0	0.1	0.15	0.2	0.3	0.4	0.5	0.6	0.7	0.8	0.9	1
Speed 1 (CFM)	1050	950										
Speed 2 (CFM)	1220	1120	1020	960								
Speed 3 (CFM)	1380	1260	1200	1100	950							
Speed 4 (CFM)	1630	1580	1500	1430	1370	1200	1050	970				
Speed 5 (CFM)	1710	1650	1600	1560	1480	1400	1250	1130	960			
Speed 6 (CFM)	1775	1725	1675	1635	1560	1495	1405	1315	1205	1040		
Speed 7 (CFM)	1840	1800	1750	1710	1640	1590	1500	1420	1330	1220	1100	930
Speed 8 (CFM)	1870	1830	1810	1800	1760	1690	1620	1520	1440	1350	1250	1150

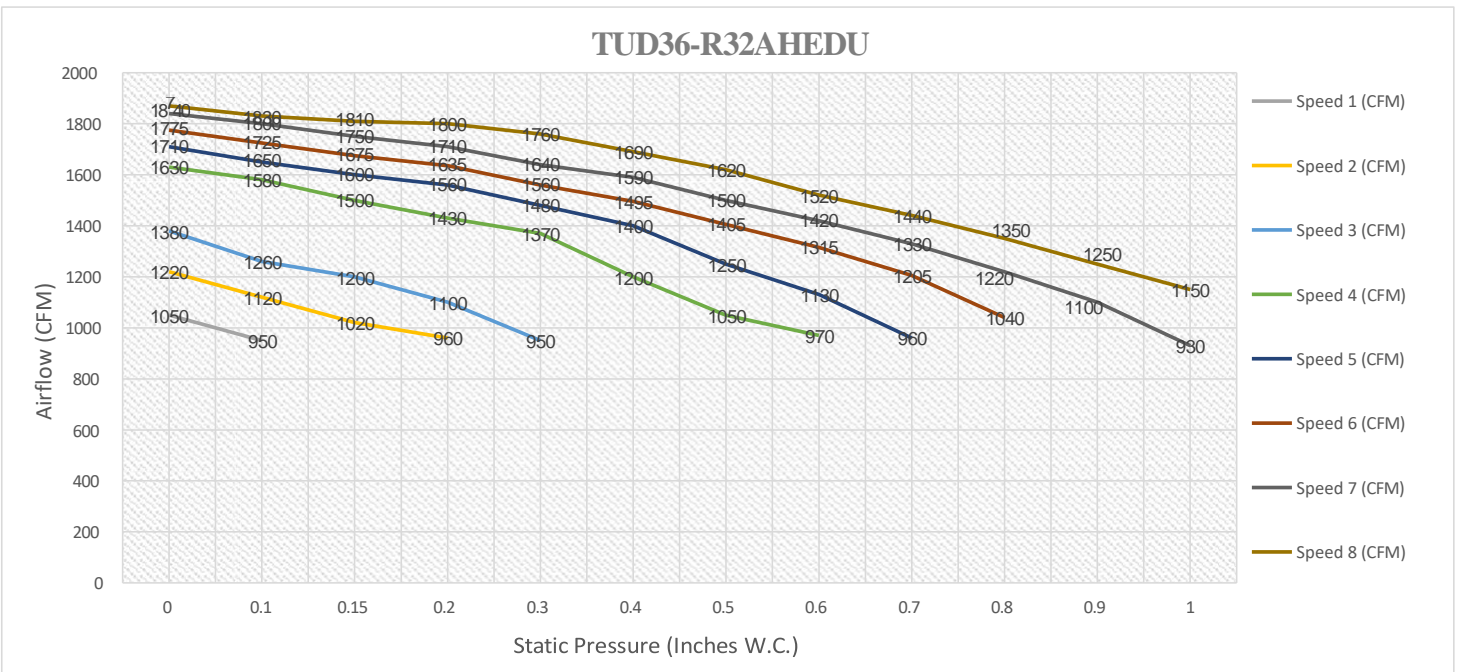

NOTE:

1. Above chart CFM ratings are based on dry coil with factory filter installed.
2. For wet coil CFM ratings, multiply the CFM by 0.96 correction factor.

DIMENSIONS

INDOOR UNIT

Unit: inch

TUD36-R32AHEDU

DIMENSIONS

A	11-5/8
B	20
H	48-1/4
W	21-1/4
D	21-1/4

FILTER SIZE

Supplied*	19-1/4 x 20-3/8 x 5/8
Suggested	19-1/4 x 20-3/8 x 1

*Supplied filter is metal mesh

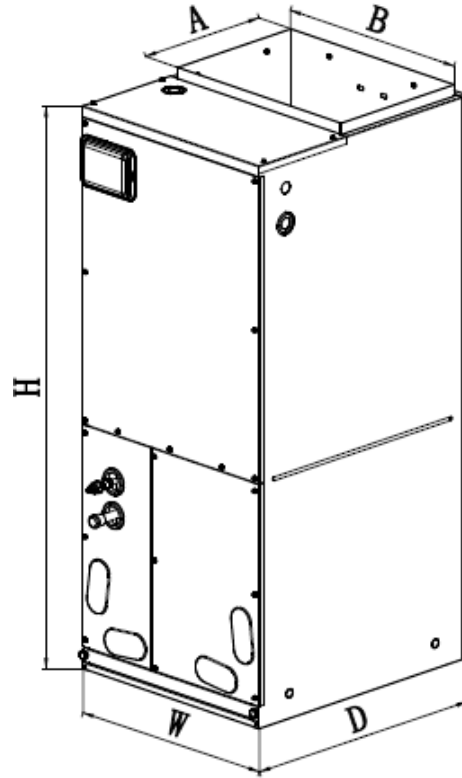

OUTDOOR UNIT

Unit: inch

TU36-R32WEDU

DIMENSIONS

A	36-3/8
B	15-13/16
C	29-3/8
D	22-7/16
E	14-9/16
F	38-1/4
G	14-5/8

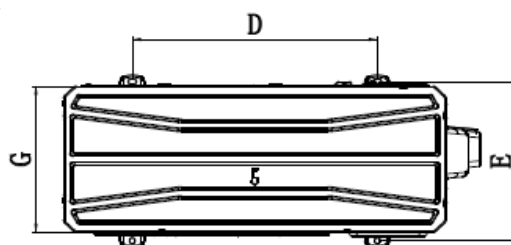
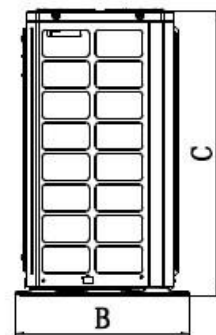
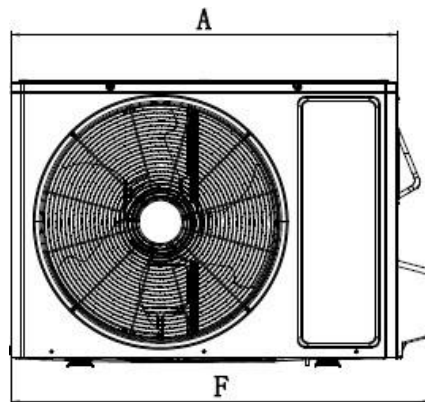

ACCESSORY HEATER AND GENERAL INFORMATION

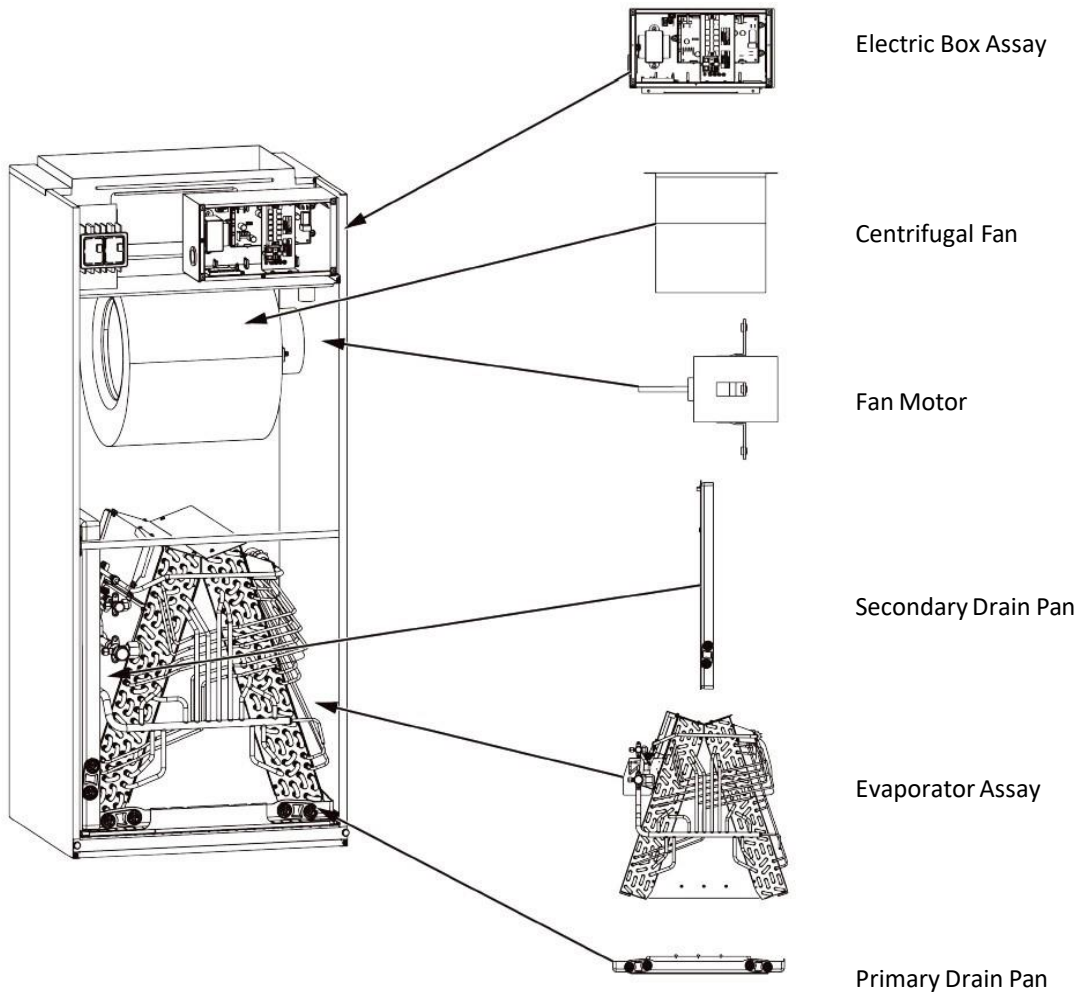

Model	Heat Kit Model	Electric Heat (kW)		Min. Circuit Ampacity (A)		Max Fuse or Breaker (A)	
		208V	230V	208V	230V	208V	230V
TUD36-R32AHEDU	ELEMHT16-5KW	3.74	4.6	31	33	35	35
	ELEMHT16-8KW	6.03	7.36	44	48	45	50
	ELEMHT16-10KW	7.49	9.2	53	58	60	60

CLEARANCES

INDOOR UNIT

Minimum clearance

FRONT

> 24

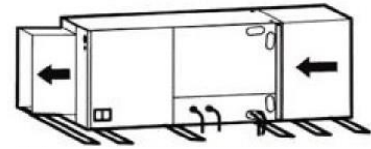
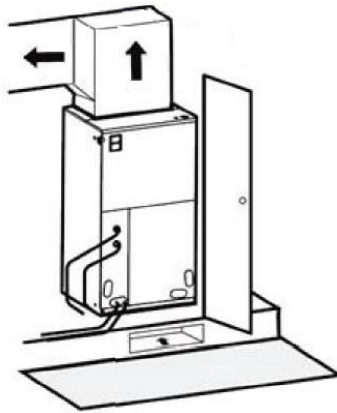

Horizontal Left Configuration - No Modification Needed

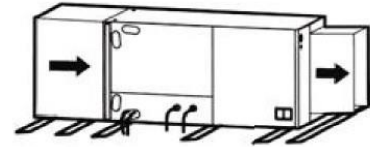

Horizontal Right Configuration - Must Relocate Drain Pan

NOTE:

Allow a minimum of 24" in front of the unit for service clearance. When installing in an area directly over a finished ceiling (such as an attic), an emergency drain pan is required directly under the unit. **See local and state codes for requirements.** When installing this unit in an area that may become wet, elevate the unit with a sturdy, non-porous material. In installations that may lead to physical damage (i.e. a garage) it is advised to install a protective barrier to prevent such damage. This air handler is designed for a complete supply and return ductwork system.

OUTDOOR UNIT

Minimum clearance

NOTE:

Install the Outdoor Unit **2 Inches** Above the Expected Snow Line

1. When one outdoor unit is to be installed.

A - E	H_b H_d H		(in)				
			a	b	c	d	e
B	-	-	-	≥ 4	-	-	-
A, B, C	-	-	≥ 12	≥ 4	≥ 4	-	-
B, E	-	-	-	≥ 4	-	-	≥ 40
A, B, C, E	-	-	≥ 12	≥ 6	≥ 6	-	≥ 40
D	-	-	-	-	-	≥ 40	-
D, E	-	-	-	-	-	≥ 40	≥ 40
B, D	$H_b < H_d$	$H_d < H$	-	≥ 4	-	≥ 40	-
	$H_b > H_d$	$H_d > H$	-	≥ 4	-	≥ 40	-
B, D, E	$H_b < H_d$	$H_d \leq 1/2H$	-	≥ 10	-	≥ 80	≥ 40
		$1/2H < H_d \leq H$	-	≥ 10	-	≥ 80	≥ 40
	$H_b > H_d$	$H_d > H$	Prohibited				
		$H_d \leq 1/2H$	-	≥ 4	-	≥ 80	≥ 40
$H_b > H_d$	$1/2H < H_d \leq H$	-	≥ 8	-	≥ 80	≥ 40	
	$H_d > H$	Prohibited					

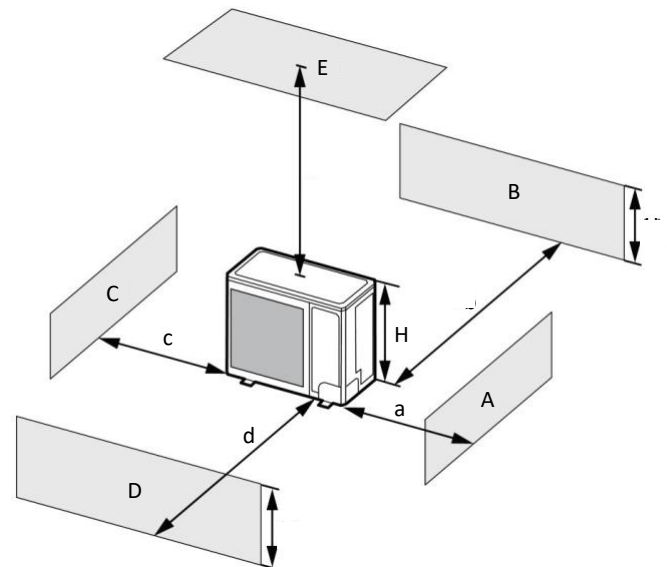

CLEARANCES

2. When two or more outdoor units are to be installed side by side.

A - E	H_b H_d H	(in)					
		a	b	c	d	e	
A, B, C	-	≥ 12	≥ 12	≥ 40	-	-	
A, B, C, E	-	≥ 12	≥ 12	≥ 40	-	≥ 40	
D	-	-	-	-	≥ 80	-	
D, E	-	-	-	-	≥ 80	≥ 40	
B, D	$H_b < H_d$	-	≥ 12	-	≥ 80	-	
	$H_b > H_d$	$H_d \leq 1/2H$	≥ 10	-	≥ 80	-	
B, D, E	$H_b > H_d$	$1/2H < H_d \leq H$	≥ 12	-	≥ 100	≥ 40	
		$H_b \leq 1/2H$	≥ 12	-	≥ 80	≥ 40	
	$H_b < H_d$	$1/2H < H_b \leq H$	≥ 12	-	≥ 100	≥ 40	
		$H_b > H$	Prohibited				
	$H_b > H_d$	$H_d \leq 1/2H$	-	≥ 10	-	≥ 100	≥ 40
		$1/2H < H_d \leq H$	-	≥ 12	-	≥ 100	≥ 40
	$H_d > H$	Prohibited					

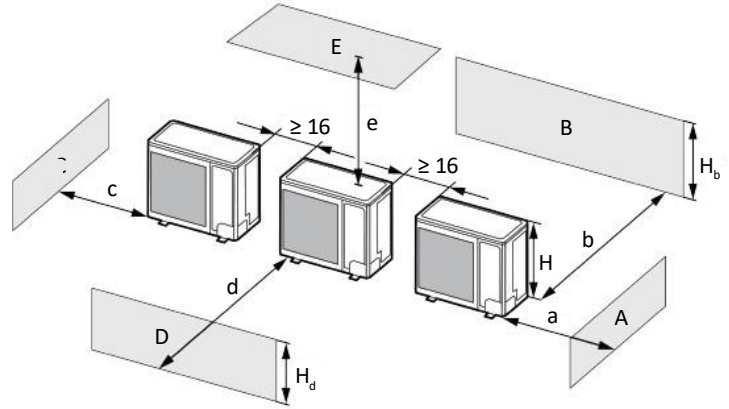

3. When outdoor units are installed in rows.

H_b H_d	(in)
$H_b \leq 1/2H$	$b \leq 10$
$1/2H < H_b \leq H$	$b \leq 12$
$H_b > H_d$	Prohibited

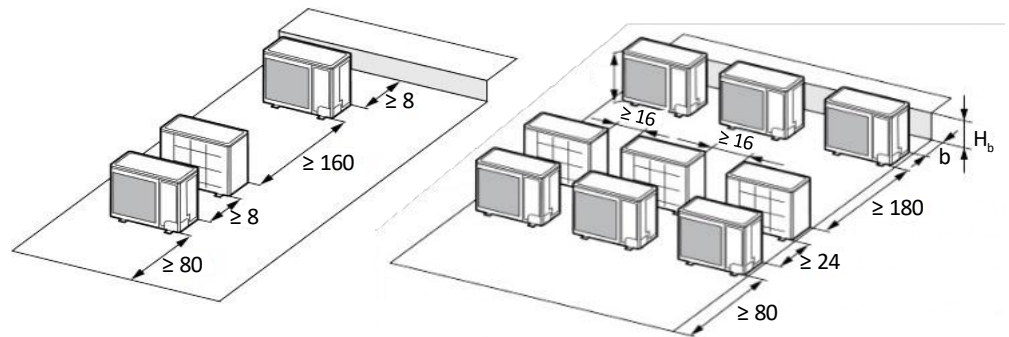

4. When outdoor units are installed one above another.

