

E3-M FILTRATION SYSTEM

INTEGRATED BYPASS, METER &
DRAIN CONNECTION SYSTEM



The E3-M connection system is a metered option and is available to use with all POE (point-of-entry) filters.

EASY REPLACEMENTS NO TOOLS REQUIRED

1. PRESS THE RED PRESSURE RELIEF VALVE TO UNSEAT THE RING



2. REMOVE SNAP RING



3. LIFT TOP CAP



WATER QUALITY OPTIMUM WORKING CONDITIONS†

ATOMUS® F11 outperforms competitive medias when one or more of the ideal water characteristics are exceeded.

Total arsenic: 0.010–0.100 mg/L	Total suspended solids: < 5 mg/L
pH: 5.5–9.5	Sulphate: < 100 mg/L
Fluoride: < 1 mg/L	Sulfides: < detect mg/L
Iron: < 0.3 mg/L	Vanadium: < 0.05 mg/L
Phosphate: < 0.55 mg/L	Hardness: < 300 mg/L
Manganese: < 0.05 mg/L	Turbidity: 5 NTU
Silica: < 35 mg/L	

NOTE: A ratio of 1:3 silica vs total hardness will maintain silica in solution and optimize performance.

APPLICATIONS

Ideal for residential, food service, rental fleets, commercial and industrial applications

Make-up water, RO pre-filtration, cooling towers, chill water loops

Process water (turbidity, particulate, colloidal suspensions)

Reduction in frequency of replacing common 2½" or 4½" housings (bigger is better)

Other water-based fluid solutions

PIONEER® As

PIONEER® As FILTRATION CARTRIDGE

The PIONEER® As utilizes an engineered binary mixed metal adsorption media (ATOMUS® F11) for the simultaneous removal of both arsenic III and V from potable water in a non-backwashing filtration design for use in both residential and commercial point-of-entry (POE) applications. PIONEER® As meets or exceeds USEPA enforceable maximum contaminant level (MCL) regulations in public drinking water of 10 parts per billion (ppb) for arsenic in water systems.

PIONEER® As is the first-of-its-kind non-backwashing whole-house filtration solution that removes both forms of arsenic (III and V) and is certified to NSF/ANSI 53 Standard for service flow rates up to 7 gpm (26.50 lpm) for 125,000 gallons of certified filtration life. This technology is so advanced that there is no required converting of arsenic III to V prior to filtration, no air-oxidation control valves, and no backwashing! This innovative POE (point-of-entry) filtration system provides FILTRATION EVERYWHERE TECHNOLOGY®.

Powdered ATOMUS® F11 media is used in the magenta series radial flow cartridge. The media is independently certified to NSF/ANSI Standard 61 and is more resistant to interference from silica, phosphorus and vanadium than other arsenic removal medias on the market today. Powder has more surface area than granular medias, which gives it the ability to address arsenic in a water stream in less than 30 seconds (versus 3 to 5 minutes with traditional granular media). Rapid kinetics is precisely what makes our unique, non-backwashing ATOMUS® F11 technology possible.

ATOMUS® F11 has been tested and proven to provide a maximum removal capacity and improved stability against pH upset to prevent possible desorption of bound arsenic both during use and in landfill conditions, ensuring successful evaluation against USEPA TCLP[®] and California Wet Tests solutions with an unparalleled, non-leachable arsenic bond.

The E3-M Cartridge Tank utilizes ENPRESS' patented industry-exclusive liner and no-tools-necessary snap ring design. Full radial seal top and bottom caps make replacement simple and allow for easy access and removal of the internal filtration solution.

For best results: use with pre- and post-filtration product solutions, including pleated filters (orange/yellow series) and carbon blocks (blue series).

TECHNICAL SCHEMATICS

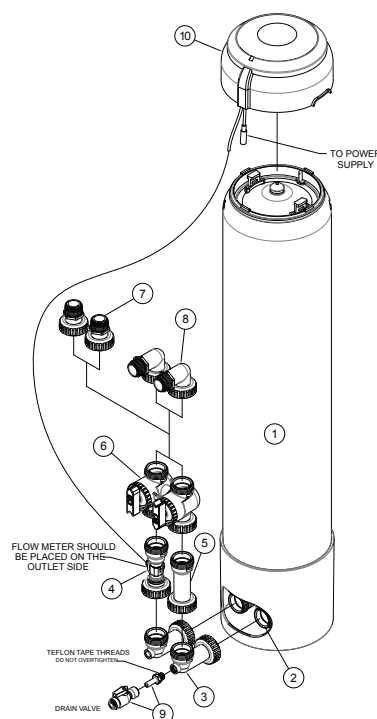

PART IDENTIFICATION

- ONE E3-M Filtration System/Housing
- In/Out Head for 1.050" Riser Pipe
- 90 Degree Vertical Elbow With/without Machined Drain Port
- Flow Meter Assembly With Cord
- Meter Spacer Assembly
- Bypass Manifold
- 1" MNPT Straight Connector
- 1" MNPT 90 Degree Elbow Connector
- 3/8" PEX Drain Valve Kit Assembly With Shut-off
- PCB Umbrella With Electronics Non-WIFI, Version 1

PIONEER® As FILTER CARTRIDGE

Thank you for choosing PIONEER®

SPECIFICATIONS

ONE E3-M Name and Part Number	Size and Micron Rating	Rated Capacity and Flow Rate	Arsenic V @ pH 6.5/8.5 and Arsenic III @ pH 6.5 Reduction*	Pressure Drop Spec
ONE E3-M System and PIONEER® As Filter				
ONE E3-M System CTA0840BBBKP5-06L00	8" x 40" / 20 Microns	Arsenic Reduction 125,000 Gallons @ 7 GPM 473,176 Liters @ 26.5 lpm @ 99.9% Arsenic Reduction	>375,000 Gallons @ 7 GPM (>1,419,529 Liters @ 26.5 lpm) @ 99.9% Arsenic Reduction	9 psid @ 7 GPM (26.5 lpm)

PIONEER® As—Arsenic III and V Removal Cartridge // PART NUMBER: CT-5020-0640RD-F11

*Claims are not performance tested by WQA, IAPMO or NSF. Performance claims are based on independent laboratory and manufacturer's internal test data. Actual performance is dependent on influent water quality, flow rates, system design and application. Results may vary. The model number of the system in which the filter component is to be used in is CTA0840BBBKP5-06L00.



IMPORTANT

DO NOT USE extra lubricants, unapproved sealants and/or tools to tighten hand-tighten only parts. Use of tools other than hand-tighten only parts voids warranty. Testing was performed under standard laboratory conditions; actual performance may vary. Flush the system and change the filter as suggested. The contaminants or other substances removed or reduced by this water filter are not necessarily in all users' water.

PERFORMANCE

Performance claims are based on independent lab results and manufacturer's internal test data. Actual performance is dependent on influent water quality, flow rates, system design and applications. Your results may vary. Performance claims are based on a complete system, including a filter, housing, and connection to a pressurized water source. This filter must be operated according to the system's specifications in order to deliver the claimed performance. It is essential to follow operational, maintenance, and filter replacement requirements, as directed for each application, for this filter and system to perform correctly. Read the Manufacturer's Performance Data Sheet accompanying the system and change the filter as suggested. The contaminants or other substances removed or reduced by this water filter are not necessarily in all users' water.

WARRANTY

LIMITED LIABILITY: ENPRESS LLC makes no warranties of any kind, expressed or implied, statutory or otherwise, and expressly disclaims all warranties of every kind concerning the product, including, without limitation, warranties of merchantability and fitness for a particular purpose, except that this product should be capable of performing as described in this product's data sheet. ENPRESS LLC's obligation shall be limited solely to the refund of the purchase price or replacement of the product proven defective, in ENPRESS LLC's sole discretion. Determination of suitability of this product for uses and applications contemplated by Buyer shall be the sole responsibility of Buyer. Use of this product constitutes Buyer's acceptance of this Limited Liability.

NOTES:

- Water conditions outside of the above specified limits may lead to a shortened filtration life.
- Cartridges may contain a very small amount of fines. After installation, flush the cartridges for at least 30 minutes prior to use.
- Micron ratings based on 85% or greater removal of a given particle size. Flush new cartridges until water runs clear prior to use.

*Water with pH > 9 may require pH adjustment for best performance. Economical treatment can still be achieved if ideal range is exceeded. Particularly for increased levels of silica and phosphate, arsenic removal media will often provide the most economical treatment when compared to other adsorptive arsenic removal medias.

^USEPA TCLP tested as non-hazardous waste safe for landfill, but due to variances in influent water quality, users are urged to perform independent verification of the non-hazardous character of spent media cartridges. Additionally, some states may have disposal criteria different from federal guidelines (TCLP). Notice: Information is believed to be reliable and is offered in good faith with no warranties or implied warranties or fitness for a particular use. Customer is responsible for determining whether use conditions and information in this document are appropriate for specific applications and for ensuring compliance with applicable laws and regulations.

This system has been tested for the reduction of the substances listed below. The concentration of the indicated substances in water entering the system was reduced to a concentration less than equal to the permissible limit for water leaving the system, as specified in NSF/ANSI 53 and P473. Minimum substance reductions are as follows:

Substance	Influent Challenge Concentration (MG/L)	Maximum Permissible Product Water Concentration (MG/L)	NSF/ANSI Standard
Arsenic	0.050 +/- 10%	0.010	53

Minimum Operating Temperature: 34 °F / 1 °C
Maximum Operating Temperature: 120 °F / 50 °C
Minimum Operating Pressure: 20 psig / 1.38 bar
Maximum Operating Pressure: 125 psig / 8.6 bar
Electrical Requirements: Grounded and unswitched 115 V outlet and 3 AAA batteries

Filter Replacement Operating Instructions: New cartridges must be flushed for a minimum of 30 minutes prior to use. System and installation to comply with federal, state, and local laws and regulations. Do not use with water that is microbiologically unsafe or unknown quality without adequate disinfection before or after the system. Manufactured from NSF/ANSI standard 61 and California Prop 65 Compliant raw materials.

CERTIFICATIONS



The ENPRESS CTA0838BBxP5-06Lyyy, CTA0840BBxP5-06Lyyy and CTA0842BBxP5-06Lyyy are certified by IAPMO R&T and WQA to NSF/ANSI 53 for Material Safety, Structural Integrity, and for the reduction of claims specified on the Performance Data Sheet.

The ENPRESS ATOMUS® F11 media inside this system is certified to NSF/ANSI 61 for Material Safety and NSF/ANSI 372 for Low Lead Content.

USEPA TCLP and WET Approved: Engineered and proven to provide maximum removal capacity and improved stability against pH upset to prevent possible desorption of bound contaminants both during operation and in landfill conditions. This ensures successful evaluation against USEPA TCLP and California WET Tests with our unparalleled, non-leachable bond.

MANUFACTURED BY



For more information, visit enpress.com or onefiltration.com

ENPRESS, LLC. // 34899 Curtiss Blvd., Eastlake Ohio 44095 // Phone: 866.859.9274 // Fax: 440.510.0202 // info@enpress.com

ENPRESS®, ONE®, CARTRIDGE TANK®, E3-M®, PIONEER®, ATOMUS® AND UMBRELLA CAP® are trademarks of ENPRESS, LLC. US and International patents, and patent pending. © ENPRESS LLC 2023 | ONE® is an ENPRESS Filtration Technology | 09/2023