

# **Citronix ci5000 Series Printer Technical Service Manual**

ci5200

ci5300

ci5500

ci5650

Revision 0.1

Part Number: 012-1002-007

**THIS PAGE INTENTIONALLY LEFT BLANK.**

## Preface

The Citronix team welcomes you to the ci5000 Series Continuous Inkjet Printer range. We are proud of this product range and the features it has to offer and are confident that this product will exceed the high expectations that you, our customers, have placed with us.

We have prepared this manual to provide comprehensive technical information on the ci5000s printers. It contains important information on how to:

- Operate the equipment safely.
- Care for and maintain the printer.
- Use the day to day functionality of the printer.
- Calibration & troubleshooting.

All rights reserved. No part of this publication may be reproduced, stored on a retrieval system, or transmitted in any form, or by any means, electronic, mechanical, photocopying, recording or otherwise, without the prior permission of Citronix Inc.

To the best of our knowledge, the information contained in this guide was correct at the time of printing. Continual enhancement of our products may result in some differences between instructions represented in this guide and your ci5000 Series Printer.

Citronix and Codes of Excellence are trademarks of Citronix Inc.

This guide was written by:

Citronix Inc.  
2241 S. Watson Road, Suite 111  
Arlington, Texas 76010  
United States of America  
[www.citronix.com](http://www.citronix.com)  
[info@citronix.com](mailto:info@citronix.com)

© Copyright Citronix Inc. 2003 – 2016



## DECLARATION of CONFORMITY

**Issuer's name:** Citronix Inc.

**Issuer's Address:** 2241 S. Watson Road, Suite 111, Arlington, Texas 76010, United States of America  
Tel: +1-817-633-3200 Fax: +1-817-633-3207 Email: info@citronix.com

Declare under sole responsibility that the products identified herein, have been designed, manufactured and tested in accordance with the following documents:

EN55022:2011	Information Technology Equipment – Radio Disturbance Characteristics – Limits and Methods of Measurement.
EN55024:2010 A1:2015	Information Technology Equipment – Immunity Characteristics – Limits and Methods of Measurement.
IEC60950-1:2005(2 <sup>nd</sup> ed)/ A1:2009/A2:2013	Information Technology Equipment - Safety - Part 1: General Requirements.
2014/35/EU	Low Voltage Directive
2014/30/EU	EMC Directive

CE-Marked accordingly



certification date May 20, 2016

Each product marketed, is identical to the representative unit tested and found to meet the standards.

Trade Name: Citronix  
Type of Product: Continuous Ink Jet Printer  
Model: ci5200, ci5300, ci5500, ci5650

### ***Signed for and on behalf of***

Citronix Inc.  
2241 S. Watson Road, Suite 111  
Arlington, Texas 76010

***\*Original signed and available from local distributor\****

\_\_\_\_\_  
Michael Embree  
Engineering Director

Signature Dated May 20, 2016

**FCC Notice**

This equipment has been tested and found to comply with the limits for a Class A digital device, pursuant to part 15 of the FCC Rules. These limits are designed to provide reasonable protection against harmful interference when the equipment is operated in a commercial environment. This equipment generates, uses, and can radiate radio frequency energy and, if not installed and used in accordance with the instruction manual, may cause harmful interference to radio communications. Operation of this equipment in a residential area is likely to cause harmful interference in which case the user will be required to correct the interference at own expense.

Any changes or modifications not expressly approved by the manufacturer could void the user's authority to operate the equipment.

### **FCC/Industry Canada Statement**

This device complies with FCC Part 15 and Industry Canada license exempt RSS standard(s). Operation is subject to the following two conditions: (1) this device may not cause interference, and (2) this device must accept any interference, including interference that may cause undesired operation of the device.

This device complies with Health Canada's Safety Code. The installer of this device should ensure that RF radiation is not emitted in excess of the Health Canada's requirement.

Changes or modifications not expressly approved by the party responsible for compliance could void the user's authority to operate the equipment.

### **French Version:**

Le présent appareil est conforme aux CNR d'Industrie Canada applicables aux appareils radio exempts de licence. L'exploitation est autorisée aux deux conditions suivantes : (1) l'appareil ne doit pas produire de brouillage, et (2) l'utilisateur de l'appareil doit accepter tout brouillage radioélectrique subi, même si le brouillage est susceptible d'en compromettre le fonctionnement

Cet appareil est conforme avec Santé Canada Code de sécurité 6. Le programme d'installation de cet appareil doit s'assurer que les rayonnements RF n'est pas émis au-delà de l'exigence de Santé Canada.

Les changements ou modifications non expressément approuvés par la partie responsable de la conformité pourraient annuler l'autorité de l'utilisateur à utiliser cet équipement.

### **European EMC Statement**

This product may cause interference if used in residential areas. Such use must be avoided unless the user takes special measures to reduce electromagnetic emissions to prevent interference to the reception of radio and television broadcasts.

## **CONTENT**

- SECTION 1: GENERAL INFORMATION**
- SECTION 2: GRAPHICAL USER INTERFACE**
- SECTION 3: PRINTER OPERATION**
- SECTION 4: INSTALLATION AND COMMISSIONING**
- SECTION 5: STATUS BAR/TROUBLESHOOTING**
- SECTION 6: CLEANING AND MAINTENANCE**
- SECTION 7: COMMUNICATIONS**
- SECTION 8: SPARES & ACCESSORIES**
- SECTION 9: CALIBRATION**
- SECTION 10: ci5650 AIR SYSTEM**
- SECTION 11: REFERENCE**

## SECTION 1: GENERAL INFORMATION

### CONTENTS

	Page
Introduction.....	1-3
Before You Begin.....	1-3
Safety Information .....	1-3
Specific Warnings .....	1-4
Health and Safety .....	1-4
Introduction.....	1-4
Basic Requirements.....	1-4
Storage .....	1-5
Fire Risk .....	1-5
Printer Overview.....	1-5
Controller Cabinet .....	1-7
Hardware Specification: .....	1-8
Interfaces:.....	1-8
Inputs (opto-isolated, open collector or TTL type): .....	1-8
Outputs:.....	1-9
User Interface and Firmware Capabilities: .....	1-9
Operating Environment: .....	1-9
Electrical Requirements: .....	1-9
Controller and Printhead Physical Characteristics:.....	1-9
Printhead and Umbilical.....	1-11
Printhead: .....	1-11
Umbilical: .....	1-11
Printhead Dimension Drawings:.....	1-11
Print Speeds and Print Quality Charts.....	1-13
Print Speed Chart - Drop Size: Normal/Internal Encoder.....	1-14
Print Speed Chart - Drop Size: Normal/External Encoder .....	1-14
Print Speed Chart - Drop Size: Macro/Internal Encoder .....	1-15

Print Speed Chart - Drop Size: Macro/External Encoder .....	1-16
Print Speed Chart - Drop Size: Micro/Internal Encoder .....	1-17
Print Speed Chart - Drop Size: Micro/External Encoder .....	1-18
Print Speed Chart - Drop Size: HS50/Internal Encoder .....	1-19
Print Speed Chart - Drop Size: HS50/External Encoder .....	1-20
Consumables and Delivery .....	1-21
Ink System .....	1-22
Ink and Makeup Tanks .....	1-24
Ink Pump .....	1-24
Ink System Valves & Manifold .....	1-24
Pressure Transducer .....	1-26
Viscometer .....	1-26
The ciEasyServ Filter Module .....	1-26
Ink System Diagram .....	1-28
Print Head .....	1-29
Drop Generator .....	1-30
Nozzle .....	1-30
Charge Electrode and Strobe .....	1-30
Phase Detector .....	1-30
Deflector Plates .....	1-30
Gutter .....	1-30
Printhead Valve .....	1-30
Phase Circuit Board .....	1-31
Printhead Cover Sensor .....	1-31
Printhead Temperature Sensor .....	1-31

## Introduction

The Citronix ci5000 Series Continuous Ink Jet Printer applies identifying marks such as “best before” dates, traceability codes, logos and batch codes onto almost any kind of material or surface. The printers comprise of hardware, software, and printing fluids that work seamlessly together to provide reliable, high quality, product coding.

This guide applies to all ci5000 Series Printers, namely ci5200, ci5300, ci5500 and ci5650 as well as specialty Printers (micro, HS50, Pigment and Heavy Pigment). Any differences between product variants are identified or highlighted.

It is intended for use by Maintenance and Distributor Service Department technicians and contains important information on how to:

- Operate the equipment safely.
- Care for and maintain the printer.
- Use the day to day functionality of the printer.
- Calibration & troubleshooting
- Component replacements

## **Before You Begin**

Before printing, make sure:

1. All warnings and notes have been read and understood.
2. The ci5000 Series Printer is correctly installed and integrated with your production line.
3. At least one message has been created, programmed and saved (refer to Section 3 Printer Operation) or select the default message.

## Safety Information

The following symbols are used in this manual. Where they appear next to a procedure or instruction, they have the significance and importance of written warnings and cautions. WARNINGS, CAUTIONS and NOTES are provided to avoid hazards and to safely operate the Printer.



A **WARNING** symbol identifies an operating procedure that if not strictly followed could result in injury or death. Warnings will be identified by a general warning symbol or a specific warning symbol.



A **CAUTION** symbol identifies an operating procedure that if not strictly followed could result in equipment damage.

## Specific Warnings

The following **Warnings** should be read and understood by all personnel involved in the operation and maintenance.



**PERSONAL INJURY:** The Printer uses extremely high voltages. Only trained and authorized personnel are allowed to perform maintenance work.



**PERSONAL INJURY:** Use safety goggles or a face mask when using Ink, Make-up or Cleaning Solvents to prevent fluids from entering the eyes.



**FIRE HAZARD:** The Ink, Make-up and Cleaning Solvents are flammable; do not smoke or use a flame in the vicinity of the Printer, servicing area or chemical storage.



**PERSONAL INJURY:** Wear protective gloves and clothing when handling Ink, Makeup or Cleaning Solvent.

## Health and Safety

### Introduction

Citronix supplies Safety Data Sheets (SDS) giving specific safety information with each of its ink, make-up and wash fluids. There are also warnings on each container. The following notes are for general guidance only.

### Basic Requirements

When used correctly, printing inks do not cause problems. However, everybody using them should be familiar with the appropriate safety standards and be aware of the precautions that should be taken. The following are basic requirements:

- Proper standards of industrial practice relating to cleanliness and tidiness must be maintained.
- Inks and their containers must be stored and handled with care.
- Smoking or the use of open flames (or other sources of ignition) in the vicinity of any inks or solvents is highly dangerous and therefore strictly inadvisable.
- All who come into contact with inks must be properly instructed in their use.

Directions for safe working practices vary according to the environment. The following are broad principles so that necessary precautions may be taken:

- Contact with the mouth must be avoided. Therefore, eating, drinking or smoking, or any personal habits or actions which may transfer ink to the mouth, must be avoided.
- Contact with the eyes must be avoided. Suitable eye protection must always be worn whenever there is any risk of splashing or misting. If ink does get into the eyes, first aid treatment is to flood the affected eye for 15 minutes with saline solution, (or clean water if saline solution is not

available), taking care not to allow the water to run into an unaffected eye. Medical aid must be obtained immediately.

- After exposure to ink, all possible traces must be washed off as soon as possible at the nearest washing facility.
- Most inks contain solvents which may injure the skin. Good working practice must always be employed and risk assessments carried out. Safety Data Sheets are available that give advice on personal protective equipment. Most gloves only offer limited and short term exposure protection and must be changed after any splashing and on a frequent basis.
- Many inks contain materials which vaporize easily and can be inhaled. Good ventilation is necessary.
- Any used cleaning materials, e.g. rags, paper wipes, are a potential fire hazard. They must be collected for safe disposal after use.
- Certain inks are allowed for use where they can be in indirect contact with food. In these cases, the following precautions must be observed in addition to those appropriate to hygiene:
- The inks must only be used in printers supplied from new for use with these inks. Any repairs and replacements must use genuine, new and unused spare parts.
- The inks must not be used in printers which have previously been used, at any time, for any other purpose.

## Storage

Printing inks must be stored in well-ventilated buildings, in areas set aside for the purpose, chosen for safety in case of fire. Materials based on volatile, flammable solvents must be stored in accordance with local regulations.

## Fire Risk

For an electrical fire, do not use water. If water must be used, such as in the case of a Nitro-cellulose ink fire (see below) the power **MUST BE REMOVED** first.

Many inks contain Nitro-cellulose as the binder and remain highly flammable when dry. Observe all warnings given on the machine and the following safety instructions:

- If there has been an accumulation of dried ink, do not use metal scrapers to remove it, as they can produce sparks.
- If dry Nitro-cellulose based ink ignites, it will generate its own oxygen and can only be extinguished by lowering the temperature with water.
- If a Nitro-cellulose fire occurs, **ENSURE THAT THE ELECTRICAL POWER IS IMMEDIATELY REMOVED FROM THE PRINTER BEFORE** water is used to extinguish the fire. Fire risk is a most important consideration where printing inks are stored and used. The degree of fire hazard will vary considerably from one type of ink or wash to another. Solvent-based inks offer a greater degree of hazard depending on the particular solvent or solvent combination. When there is a particular hazard the appropriate information is given on the SDS.

## Printer Overview

The Printer consists of a Controller cabinet and a print head that are connected by a Flexible conduit. They work seamlessly together to create reliable product coding. The cabinet is split into an electronics compartment and a fluid compartment. The electronics compartment houses the controller PCB, has the

touch screen interface and all interfacing connectors, Low & High voltage power supplies, Pump Motor, and the power switch.

The fluids compartment houses the ink system, filter module and the ink and make up tanks. These tanks are filled using their respective fill ports located on the top of the printer.

## Controller Cabinet

The front half of the controller cabinet consists of the electronics compartment. The cover, also known as the tablet has the touchscreen display, ciSafeFill Reader and controller PCB. The right hand side of the electronics cabinet houses the air filter. The left side has the accessory connectors (Beacon, Photocell and encoder) power plug and the power on/off button.

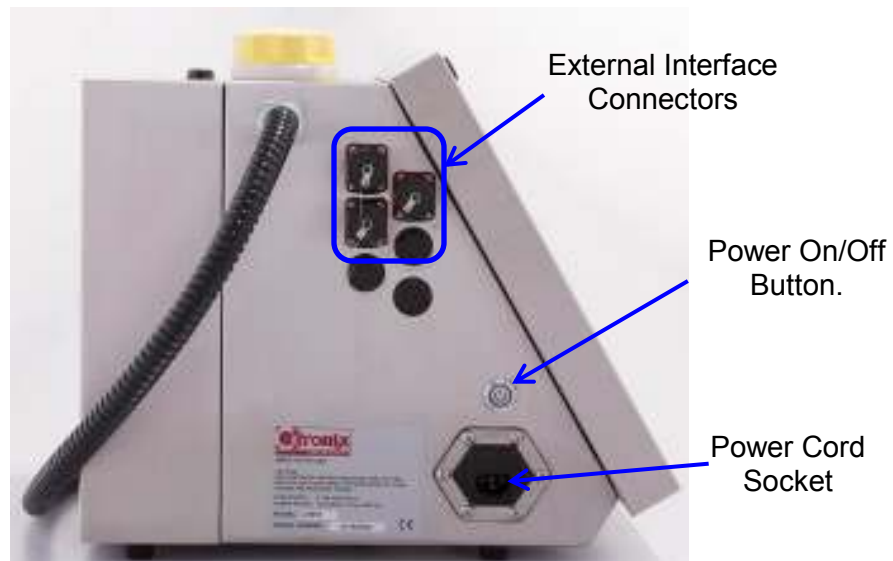



**Hardware Specification:**

<b>Single Printhead Control</b>	55-88 KHz
<b>Processor</b>	Cold Fire V4
<b>Speed</b>	250Mhz
<b>Memory</b>	256Mb Flash and 256Mb RAM

**Interfaces:**

ci5200	ci5300	ci5500/ci5650
1 RS232	1 RS232	1 Ethernet
		1 RS232 (1200 up to 115.2KB)
USB	USB	USB
SB Card	SB Card	SB Card

**Inputs (opto-isolated, open collector or TTL type):**

ci5200	ci5300/ci5500/ci5650
1 photocell	2 photocell*
1 shaft encoder	1 shaft encoder
	6 programmable**

*\*Programmable options for Photocell 2*

*\*\*Remote message selection – 255 possible selections*

## Outputs:

- 3 programmable alarms – Warning, Failure, Print Ready (Open Collector, 150mA sinking)
- Programmable dry contact relay
- External Power (+24VDC 500mA)

## User Interface and Firmware Capabilities:

Color Capacitance touch screen	Graphic downloadable
On board Help/Diagnostics	Integrated graphic creator / editor
Intuitive icon based operation	Automatic diagnostics
WYSIWYG message editing	Event log
Pick and place by pixel field based formatting	Service reminders
Message/Graphic Storage – up to 1000 messages*	Tower Printing Functions
Single button start and stop operation	Continuous print capability
Programmable Password security	Backup / restore functions
Real and expiration time and date coding	Multiple operator languages
Shift and rollover time and date coding	Multi-national character printing (Unicode)
Product and batch counting coding	Downloadable firmware updates (Ethernet or USB)
	Internet browser interface for ci5500/ci5650

\*Depending on the size of the messages

## Operating Environment:

<b>Temperature</b>	35° – 113° F (5° – 45° C)
<b>% Relative Humidity</b>	10-90% (non-condensing)

## Electrical Requirements:

<b>Auto Ranging</b>	90-260VAC (3 Amp)
<b>Frequency</b>	50-60 Hz

## Controller and Printhead Physical Characteristics:

	ci5200	ci5300
<b>Enclosure</b>	Black Powder Coated Steel	304 grade Stainless Steel
<b>Environmental</b>	IP55	IP55
<b>Printer Weight</b>	38.4 lbs.*	38.4 lbs.*
<b>Weight Printhead*</b>	2 lbs.	2 lbs.

	ci5500	ci5650
--	--------	--------

<b>Enclosure</b>	304 grade Stainless Steel	316 grade Stainless Steel
<b>Environmental</b>	IP55	Designed to IP65
<b>Printer Weight</b>	38.4 lbs.*	40.3 lbs.*
<b>Weight Printhead *</b>	2 lbs.	2 lbs.

\* The weight of the Printhead and conduit is included in the Printer weight.

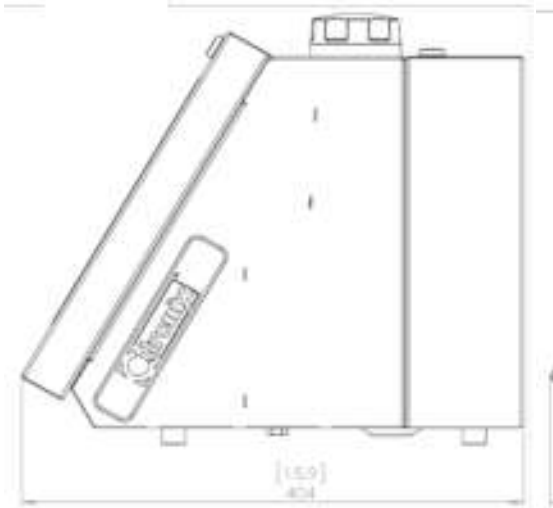

**Ci5200/ci5300/ci5500 Side View**

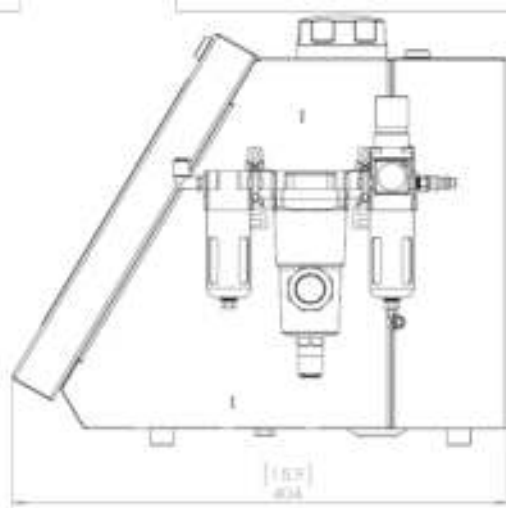

**ci5650 Side View**

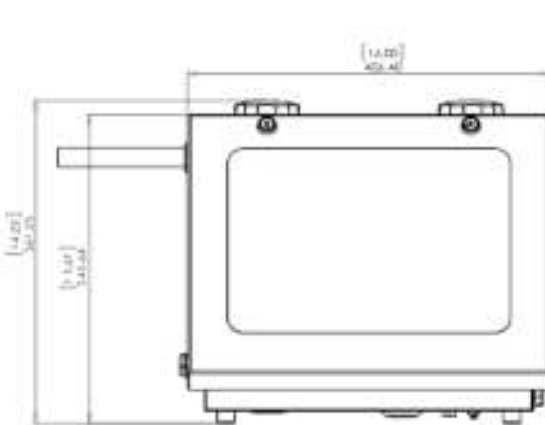

**Ci5200/ci5300/ci5500 Front View**

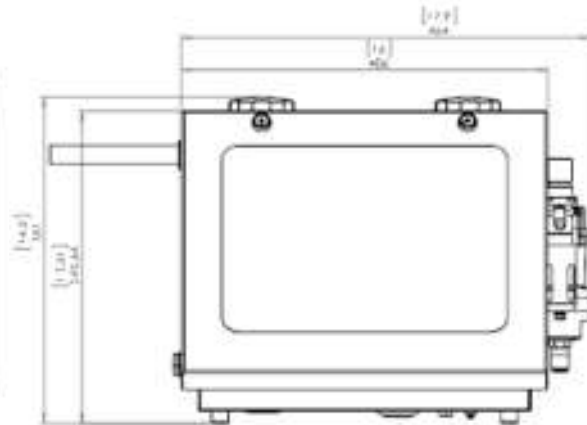

**ci5650 Front View**

Cabinet Dimensions	ci5200, ci5300 & ci5500	ci5650
<b>Height</b>	14.2 inches (361mm)	14.2 Inches (361mm)
<b>Width</b>	16 inches (406mm)	17.7 inches (450mm)
<b>Depth</b>	15.9 inches (404mm)	15.9 inches (404mm)

## Printhead and Umbilical

### Printhead:

<b>Technology</b>	Continuous Ink Jet (CIJ)
<b>Print</b>	Text, Graphics, Bar codes, Autocodes
<b>Printhead Orientation</b>	Omni-directional

### Umbilical:

Three Umbilical lengths are available on all printer types; 9 feet (2.7 meters), 15 feet (4.5 meters), or 20 feet (6 meters).

**IP55** – Protected against dust and has limited ingress (no harmful deposit). Protected against low-pressure Jets of water from all directions; limited ingress permitted.

**IP65** – Totally protected against dust. Protected against low-pressure Jets of water from all directions; limited ingress permitted.

### Printhead Dimension Drawings:

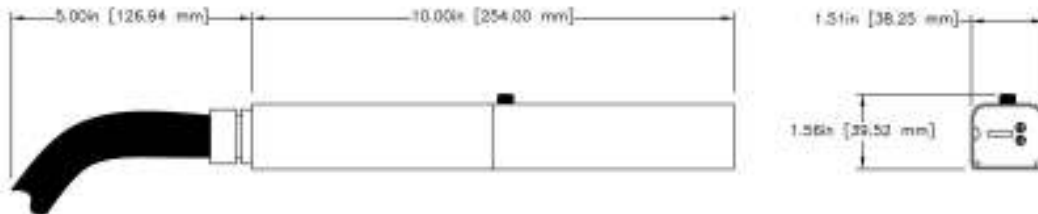

**Straight Printhead Umbilical Fitting  
(ci5200/ci5300/ci5500/ci5650)**



**Access for Straight Printhead Umbilical Fitting  
(ci5200/ci5300/ci5500/ci5650)**

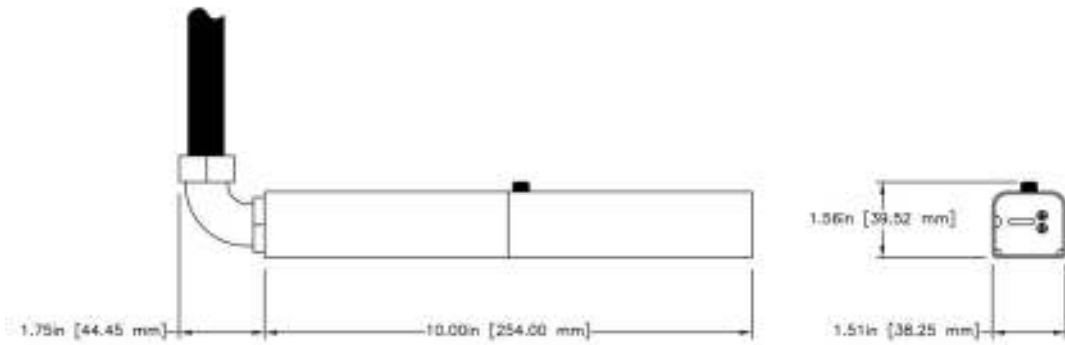

**90 Degree Printhead Umbilical Fitting  
(ci5500/ci5650 option)**

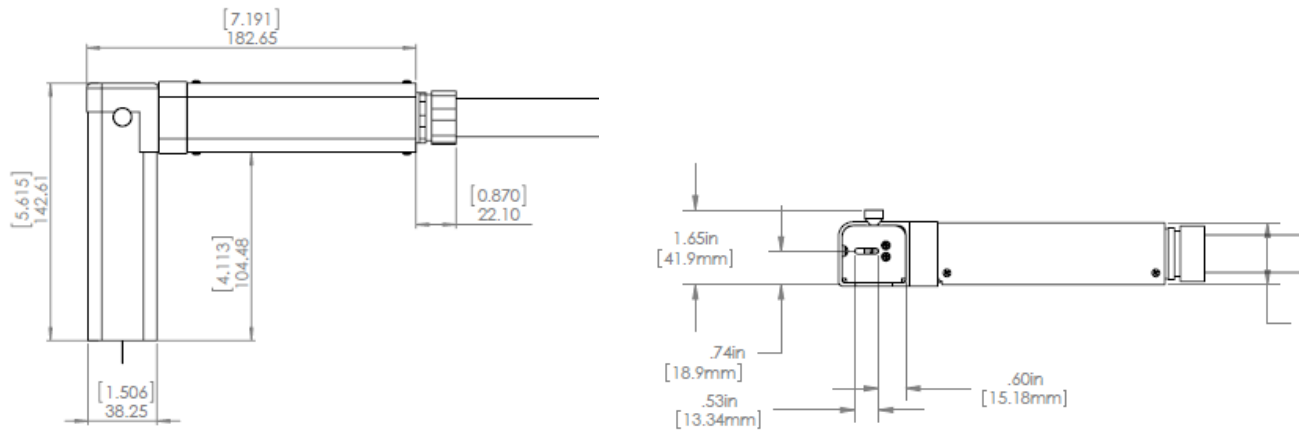

**Right Angle Printhead  
(ci5500/ci5650 option)**

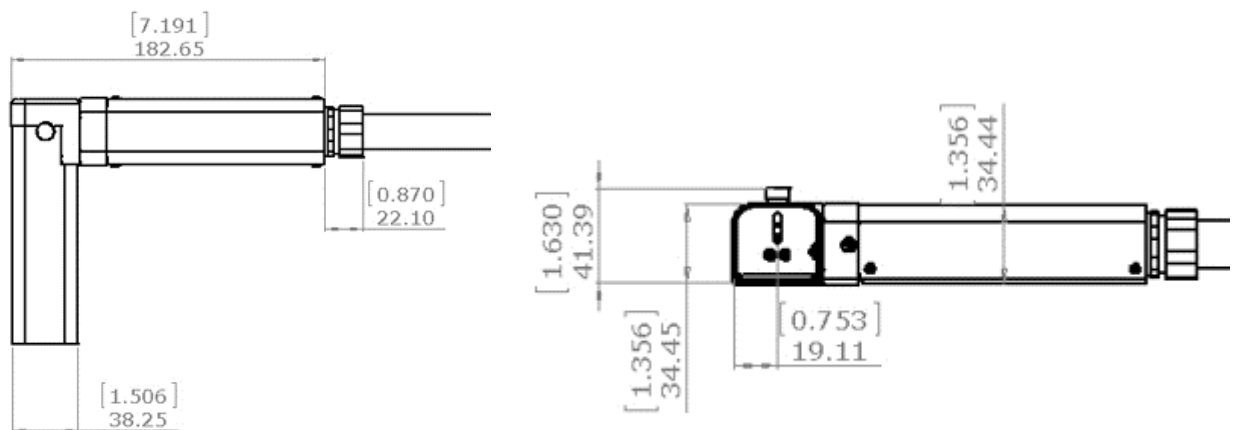

## In-Line Right Angle Printhead (ci5500/ci5650 option)

### Print Speeds and Print Quality Charts

The line speed at which the product passes the Printhead will affect print quality. The following pages show how to determine the maximum line speeds for each print quality setting. These speeds charts are calculated at 50 dpi (dots per inch).



When determining the Print settings for the application, the following factors need to be considered:

- Line Speed
- Pixel Setting (vertical resolution)
- Print Resolution or dpi (horizontal resolution or raster pitch)
- Whether an external or internal encoder is used

\*For more details reference Section 3 Printer Operation

**NOTE:** *Print Quality/Speed may be selected in increments of 20 to optimize for each application. 300 is the best quality; 0 is the fastest speed. The Speed Chart shows speeds at 0, 100, 200 and 300.*

**NOTE:** *ci5200 is available only in Macro mode. Micro and HS50 models are available only with ci5500 and ci5650.*

**NOTE:** *In the following Charts the Characters per second are based on 50 dpi.*

**Print Speed Chart - Drop Size: Normal/Internal Encoder**

Pixel Setting	Print Speed / Quality Selection	Characters per second	Maximum Line Speed	
			Feet per minute	Meters per minute
1L5	0	3213	1928	588
1L5	100	1428	857	261
1L5	200	989	593	181
1L5	300	756	454	138
1L7	0	2142	1285	392
1L7	100	989	593	181
1L7	200	676	406	124
1L7	300	514	308	94
1L9	0	1224	857	261
1L9	100	648	454	138
1L9	200	441	308	94
1L9	300	334	234	71
1L12	0	876	701	214
1L12	100	419	335	102
1L12	200	283	227	69
1L12	300	214	171	52
1L16	0	292	350	107
1L16	100	178	214	65
1L16	200	126	151	46
1L16	300	97	117	36
2L7	0	1285	771	235
2L7	100	756	454	138
2L7	200	494	297	90
2L7	300	330	198	60
1L19	0	237	308	94
1L19	100	145	188	57
1L19	200	101	131	40
1L19	300	77	100	31
1L25	0	104	188	57
1L25	100	71	129	39
1L25	200	51	92	28
1L25	300	40	71	22
3L7	0	559	335	102
3L7	100	494	297	90
3L7	200	313	188	57
3L7	300	207	124	38
1L31	0	56	157	48
1L31	100	37	104	32
1L31	200	26	74	23
1L31	300	21	58	18
4L7	0	476	286	87
4L7	100	389	234	71
4L7	200	214	129	39
4L7	300	143	86	26

**Print Speed Chart - Drop Size: Normal/External Encoder**

Pixel Setting	Print Speed / Quality Selection	Characters per second	Maximum Line Speed	
			Feet per minute	Meters per minute
1L5	0	3083	1850	564
1L5	100	1370	822	251
1L5	200	949	569	173
1L5	300	725	435	133
1L7	0	2055	1233	376
1L7	100	949	569	173
1L7	200	649	389	119
1L7	300	493	296	90
1L9	0	1174	822	251
1L9	100	622	435	133
1L9	200	423	296	90
1L9	300	320	224	68
1L12	0	841	673	205
1L12	100	402	322	98
1L12	200	272	218	66
1L12	300	206	164	50
1L16	0	280	336	103
1L16	100	171	206	63
1L16	200	121	145	44
1L16	300	93	112	34
2L7	0	1233	740	226
2L7	100	725	435	133
2L7	200	474	285	87
2L7	300	316	190	58
1L19	0	228	296	90
1L19	100	139	180	55
1L19	200	96	125	38
1L19	300	74	96	29
1L25	0	100	180	55
1L25	100	69	123	38
1L25	200	49	88	27
1L25	300	38	69	21
3L7	0	536	322	98
3L7	100	474	285	87
3L7	200	301	180	55
3L7	300	199	119	36
1L31	0	54	151	46
1L31	100	36	100	30
1L31	200	25	71	22
1L31	300	20	55	17
4L7	0	457	274	84
4L7	100	374	224	68
4L7	200	206	123	38
4L7	300	137	82	25

### Print Speed Chart - Drop Size: Macro/Internal Encoder

Pixel Setting	Print Speed / Quality Selection	Characters per second	Maximum Line Speed	
			Feet per minute	Meters per minute
1L5	0	2277	1366	416

1L5	100	1012	607	185
1L5	200	700	420	128
1L5	300	536	321	98
1L7	0	1518	911	278
1L7	100	700	420	128
1L7	200	479	288	88
1L7	300	364	219	67
1L9	0	976	683	208
1L9	100	459	321	98
1L9	200	312	219	67
1L9	300	237	166	50
1L12	0	525	420	128
1L12	100	285	228	69
1L12	200	195	156	48
1L12	300	148	119	36
1L16	0	285	341	104
1L16	100	126	152	46
1L16	200	89	107	33
1L16	300	69	83	25
2L7	0	911	546	167
2L7	100	536	321	98
2L7	200	350	210	64
2L7	300	233	140	43
1L19	0	168	219	67
1L19	100	103	133	41
1L19	200	71	93	28
1L19	300	55	71	22
1L25	0	74	133	41
1L25	100	51	91	28
1L25	200	36	64	20
1L25	300	29	52	16
3L7	0	396	238	72
3L7	100	350	210	64
3L7	200	222	133	41
3L7	300	147	88	27
1L31	0	43	121	37
1L31	100	27	77	23
1L31	200	20	55	17
1L31	300	15	42	13
4L7	0	314	188	57
4L7	100	260	156	48
4L7	200	152	91	28
4L7	300	101	61	19

### Print Speed Chart - Drop Size: Macro/External Encoder

Pixel Setting	Print Speed / Quality Selection	Characters per second	Maximum Line Speed	
			Feet per minute	Meters per minute
1L5	0	2185	1311	400
1L5	100	971	583	178
1L5	200	672	403	123

1L5	300	514	308	94
1L7	0	1456	874	266
1L7	100	672	403	123
1L7	200	460	276	84
1L7	300	350	210	64
1L9	0	936	655	200
1L9	100	441	308	94
1L9	200	300	210	64
1L9	300	227	159	48
1L12	0	504	403	123
1L12	100	273	218	67
1L12	200	187	150	46
1L12	300	142	114	35
1L16	0	273	328	100
1L16	100	121	146	44
1L16	200	86	103	31
1L16	300	66	79	24
2L7	0	874	524	160
2L7	100	514	308	94
2L7	200	336	202	61
2L7	300	224	134	41
1L19	0	161	210	64
1L19	100	98	128	39
1L19	200	68	89	27
1L19	300	52	68	21
1L25	0	71	128	39
1L25	100	49	87	27
1L25	200	34	62	19
1L25	300	28	50	15
3L7	0	380	228	69
3L7	100	336	202	61
3L7	200	213	128	39
3L7	300	141	85	26
1L31	0	42	117	36
1L31	100	26	74	23
1L31	200	19	52	16
1L31	300	14	40	12
4L7	0	301	181	55
4L7	100	250	150	46
4L7	200	146	87	27
4L7	300	97	58	18

### Print Speed Chart - Drop Size: Micro/Internal Encoder

Pixel Setting	Print Speed / Quality Selection	Characters per second	Maximum Line Speed	
			Feet per minute	Meters per minute
1L5	0	3370	2022	616
1L5	100	1498	899	274
1L5	200	1037	622	190
1L5	300	793	476	145
1L7	0	2247	1348	411

1L7	100	1037	622	190
1L7	200	709	426	130
1L7	300	539	324	99
1L9	0	1444	1011	308
1L9	100	680	476	145
1L9	200	462	324	99
1L9	300	350	245	75
1L12	0	266	213	65
1L12	100	169	135	41
1L12	200	125	100	30
1L12	300	96	77	23
1L16	0	153	184	56
1L16	100	96	116	35
1L16	200	67	81	25
1L16	300	52	62	19
2L7	0	1498	899	274
2L7	100	843	506	154
2L7	200	518	311	95
2L7	300	355	213	65
1L19	0	259	337	103
1L19	100	152	197	60
1L19	200	105	137	42
1L19	300	81	105	32
1L25	0	76	213	65
1L25	100	48	135	41
1L25	200	34	96	29
1L25	300	27	75	23
3L7	0	613	368	112
3L7	100	518	311	95
3L7	200	329	197	60
3L7	300	221	133	40
1L31	0	61	172	52
1L31	100	39	109	33
1L31	200	28	78	24
1L31	300	22	60	18
4L7	0	499	300	91
4L7	100	408	245	75
4L7	200	225	135	41
4L7	300	150	90	27

### Print Speed Chart - Drop Size: Micro/External Encoder

Pixel Setting	Print Speed / Quality Selection	Characters per second	Maximum Line Speed	
			Feet per minute	Meters per minute
1L5	0	3234	1940	591
1L5	100	1437	862	263
1L5	200	995	597	182
1L5	300	761	457	139
1L7	0	2156	1293	394
1L7	100	995	597	182
1L7	200	681	408	124

1L7	300	517	310	95
1L9	0	1386	970	296
1L9	100	652	457	139
1L9	200	443	310	95
1L9	300	336	235	72
1L12	0	255	204	62
1L12	100	162	129	39
1L12	200	120	96	29
1L12	300	92	74	23
1L16	0	147	176	54
1L16	100	92	111	34
1L16	200	65	78	24
1L16	300	50	60	18
2L7	0	1437	862	263
2L7	100	808	485	148
2L7	200	497	298	91
2L7	300	340	204	62
1L19	0	249	323	99
1L19	100	146	189	58
1L19	200	101	132	40
1L19	300	78	101	31
1L25	0	73	204	62
1L25	100	46	129	39
1L25	200	33	92	28
1L25	300	26	72	22
3L7	0	588	353	108
3L7	100	497	298	91
3L7	200	315	189	58
3L7	300	212	127	39
1L31	0	59	165	50
1L31	100	37	105	32
1L31	200	27	75	23
1L31	300	21	58	18
4L7	0	479	287	88
4L7	100	392	235	72
4L7	200	216	129	39
4L7	300	144	86	26

### Print Speed Chart - Drop Size: HS50/Internal Encoder

Pixel Setting	Print Speed / Quality Selection	Characters per second	Maximum Line Speed	
			Feet per minute	Meters per minute
1L5	0	3472	2083	635
1L5	100	1543	926	282
1L5	200	1068	641	195
1L5	300	817	490	149
1L7	0	2315	1389	423
1L7	100	1068	641	195
1L7	200	731	439	134
1L7	300	556	333	102
1L9	0	1323	926	282

1L9	100	700	490	149
1L9	200	476	333	102
1L9	300	361	253	77
1L12	0	947	758	231
1L12	100	453	362	110
1L12	200	306	245	75
1L12	300	231	185	56
1L16	0	316	379	115
1L16	100	193	231	71
1L16	200	136	163	50
1L16	300	105	126	38
2L7	0	1389	833	254
2L7	100	817	490	149
2L7	200	534	321	98
2L7	300	356	214	65
1L19	0	256	333	102
1L19	100	156	203	62
1L19	200	109	141	43
1L19	300	83	108	33
1L25	0	73	203	62
1L25	100	50	139	42
1L25	200	35	99	30
1L25	300	28	77	24
3L7	0	604	362	110
3L7	100	534	321	98
3L7	200	339	203	62
3L7	300	228	137	42
1L31	0	61	170	52
1L31	100	40	113	34
1L31	200	29	80	24
1L31	300	22	62	19
4L7	0	514	309	94
4L7	100	421	253	77
4L7	200	231	139	42
4L7	300	154	93	28

### Print Speed Chart - Drop Size: HS50/External Encoder

Pixel Setting	Print Speed / Quality Selection	Characters per second	Maximum Line Speed	
			Feet per minute	Meters per minute
1L5	0	3332	1999	609
1L5	100	1481	888	271
1L5	200	1025	615	187
1L5	300	784	470	143
1L7	0	2221	1333	406
1L7	100	1025	615	187
1L7	200	701	421	128
1L7	300	533	320	97
1L9	0	1269	888	271
1L9	100	672	470	143
1L9	200	457	320	97

1L9	300	346	242	74
1L12	0	909	727	222
1L12	100	435	348	106
1L12	200	294	235	72
1L12	300	222	178	54
1L16	0	303	363	111
1L16	100	185	222	68
1L16	200	131	157	48
1L16	300	101	121	37
2L7	0	1333	800	244
2L7	100	784	470	143
2L7	200	513	308	94
2L7	300	342	205	62
1L19	0	246	320	97
1L19	100	150	195	59
1L19	200	104	136	41
1L19	300	80	104	32
1L25	0	70	195	59
1L25	100	48	133	41
1L25	200	34	95	29
1L25	300	26	74	23
3L7	0	579	348	106
3L7	100	513	308	94
3L7	200	325	195	59
3L7	300	218	131	40
1L31	0	58	163	50
1L31	100	39	108	33
1L31	200	27	77	23
1L31	300	21	60	18
4L7	0	494	296	90
4L7	100	404	242	74
4L7	200	222	133	41
4L7	300	148	89	27

## Consumables and Delivery



<b>Ink/Makeup Types</b>	Full range – MEK, Acetone, Ethanol
<b>Ink/Makeup Colors</b>	Black, Red, Blue, Yellow, Green, White, UV Readable
<b>Dry Time</b>	Quick dry to immediate
<b>Ink Bottles</b>	750 ml (25.4 oz)
<b>Makeup Bottles</b>	750 ml (25.4 oz)
<b>Ink Tank</b>	1.9 L (64 oz)
<b>Makeup Tank</b>	2.25 L (76 oz)

Ink/Makeup options for all Printers are shown in the following table.

		ci5200	ci5300	ci5500	ci5650	Micro	HS50	Pigment	Heavy Pigment
MEK Black	Black	•	•	•	•	•	•		
Ethanol Black	Black	•	•	•	•	•	•		
MEK Red	Red	•	•	•	•	•	•		
MEK Blue	Blue	•	•	•	•	•	•		
Acetone Black	Black	•	•	•	•				
MEK Plastic	Black		•	•	•				
MEK UV Readable	UV Readable		•	•	•				
MEK Alcohol Resistant	Black		•	•	•				
MEK Caustic Washable Green	Green		•	•	•				
MEK Caustic Washable	Black		•	•	•				
MEK Thermotropic BLK-Red	Black to Red		•	•	•				
MEK Plastic Plus	Black		•	•	•				
Acetone/Ethanol Black	Black		•	•	•				
Red Food Grade	Red		•	•	•				
Blue Food Grade	Blue		•	•	•				
Acetone Yellow Pigment	Yellow							•	
MEK Yellow Pigment	Yellow							•	
MEK Black Pigment	Black							•	
Acetone Heavy Pig White	White								•

## Ink System

The inks system keeps the ink optimally conditioned for reliable printing and cleaning/flushing of the printhead.

The  filter module conditions the ink for optimal performance. It comes in a clean, quick, easy to replace quick connect module. The  filter module and air filter are the only two items that require periodic servicing.

The Ink and Make-up tanks are topped up using their respective fill ports located on the top of the printer.

The following components are housed within the Ink system enclosure:

- Ink and Make-up Fill Ports
- Ink and Makeup Tanks

- Ink Pump
- Ink System Valves and Manifold
- Pressure Transducer
- Viscometer
- Filter Module
- Fluid Level Sense

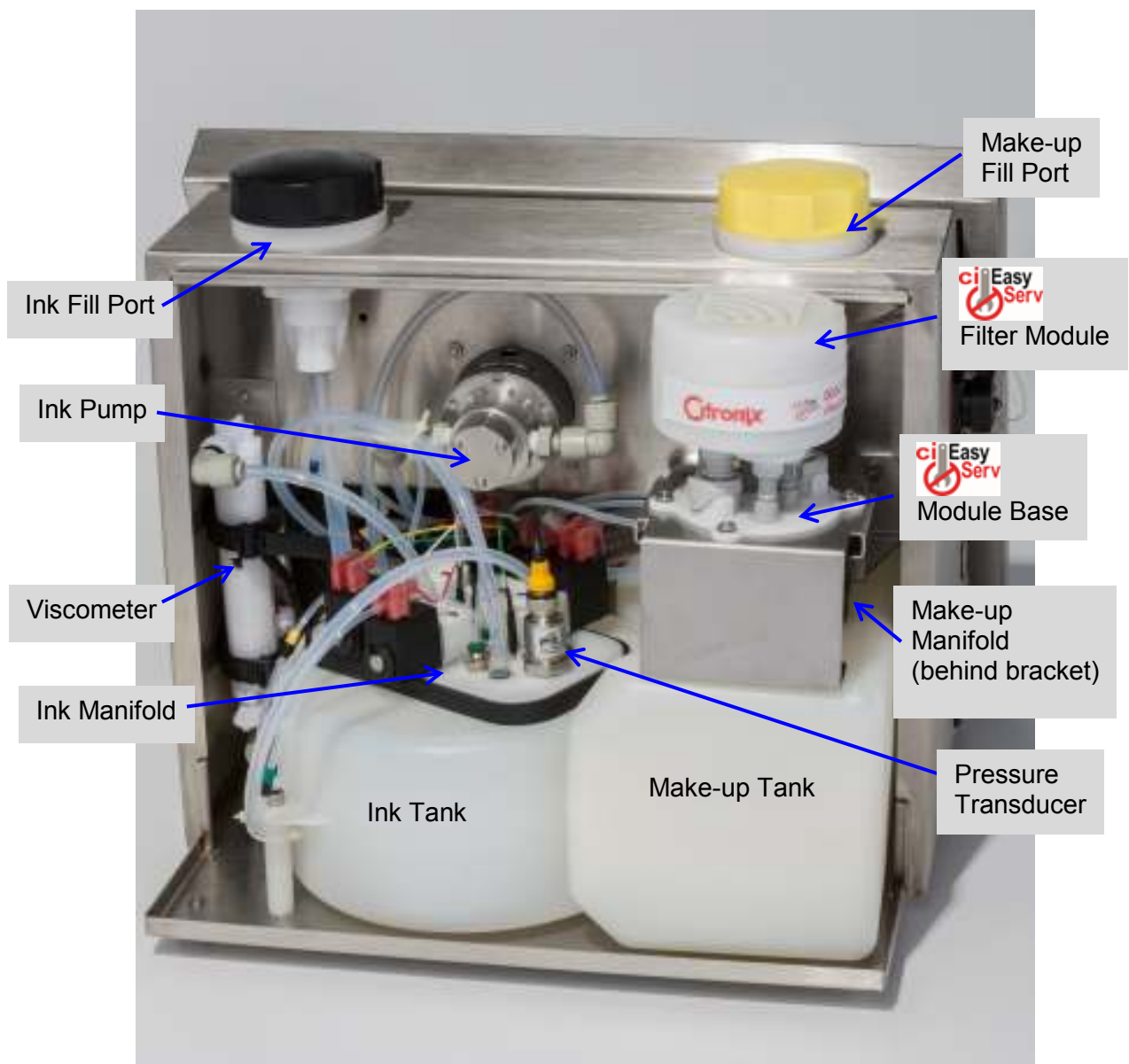

## Ink and Makeup Tanks

The Ink tank holds 1.9 liters of Ink and the Makeup tank holds 2.25 liters of Makeup.

## Ink Pump

The pump motor is on the electrical side of the enclosure, and the Ink pump is on the fluidic side of the enclosure isolated through a Teflon seal. The motor is magnetically coupled to the pump.

***NOTE:*** *Further troubleshooting/testing and adjustments explained in SECTION 5 Status Bar & Troubleshooting*





**CAUTION:** Dry Ink residue in the Ink pump may cause pump to de-couple from the motor. If the Printer is left idle for more than two weeks, ensure the Printer is flushed completely of all Ink residues. To remedy, squirt Cleaning Solvent directly into the pump head (using a Squirt Bottle) via the inlet or outlet and allow to sit with solvent in the pump for 2 minutes to loosen dried ink. Repeat until the pump is free, or replace if not free after 10 repeated steps.

## Ink System Valves & Manifold

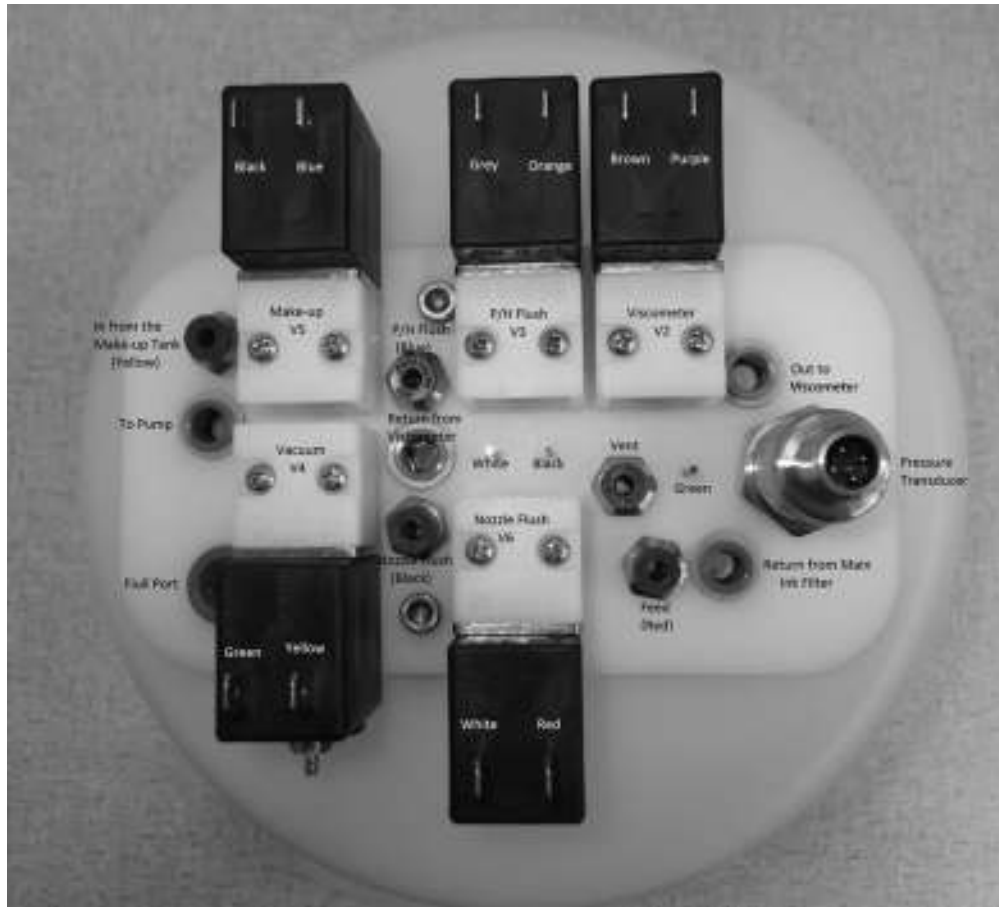
The Ink System Valves control the various Ink and Makeup supplies.



Valves can be tested by pressing the [Menu]  tab on the Main screen and then press [Service]  . Press the [Test Valves]  button in the Navigational Tool Bars. Pressing/selecting a valve while in this screen will activate the valve. Pressing/Selecting the “No Valve” or a different valve will deactivate the valve. This will allow the user to test the operation of each valve.

**NOTE:** The [Test Valve]  screen cannot be selected while the jet is on.



## Pressure Transducer

The Pressure Transducer monitors the operating Ink pressure and sends a signal to the CPU board for increasing/decreasing the pump revolutions per second (RPS) to maintain a set operating pressure.

***NOTE:*** Further troubleshooting/testing and adjustments are explained in SECTION 6 Cleaning and Maintenance/Service Routines

## Viscometer

The Viscometer is an instrument used to measure viscosity of the Ink. Its method involves moving a stainless ball to the top of the glass tube, then releasing it. The release time is marked and timed, from the top of the viscometer to the bottom where an inductive coil detects the ball. The shorter the ball fall time, the thinner the Ink. The longer the ball fall time, the thicker the Ink.

***NOTE:*** Further troubleshooting/testing and adjustments are explained in SECTION 6 Cleaning and Maintenance/Fault Finding & Repair

## The ciEasyServ Filter Module



The  filter module enables quick and easy “tool-less” filter changing. The module and base have self-sealing valves for a “no drip” clean change.

After scanning the  tag the firmware will walk the user through the simple change and then start an automatic bleed procedure, filling the filter module with ink and bleeding the air from the new Filter Module. Once this procedure is complete, the printer is ready for use.



The filter is easily removed by pressing the 2 quick release buttons (shown below) and lifting the filter module up. Then taking the new filter module (after scanning) and align the module to the base and pressing down until 2 clicks are heard. This means the safety locks have engaged.

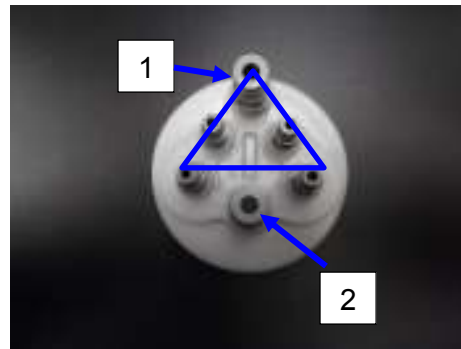
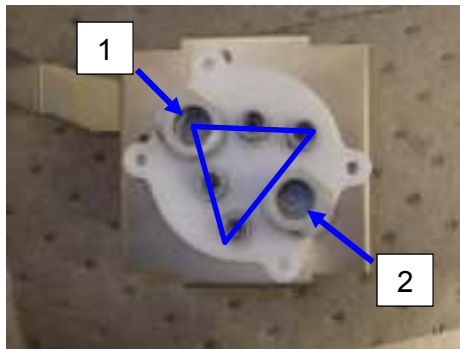
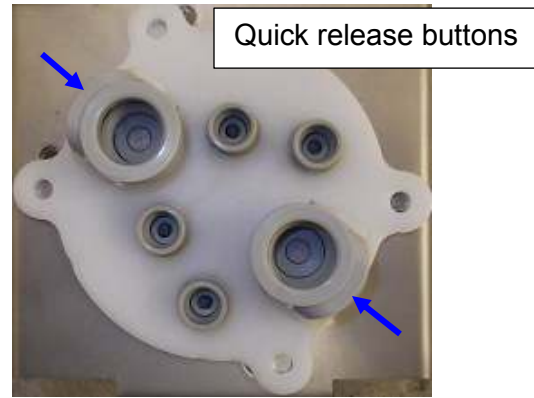

Alignment

### Ink System Diagram

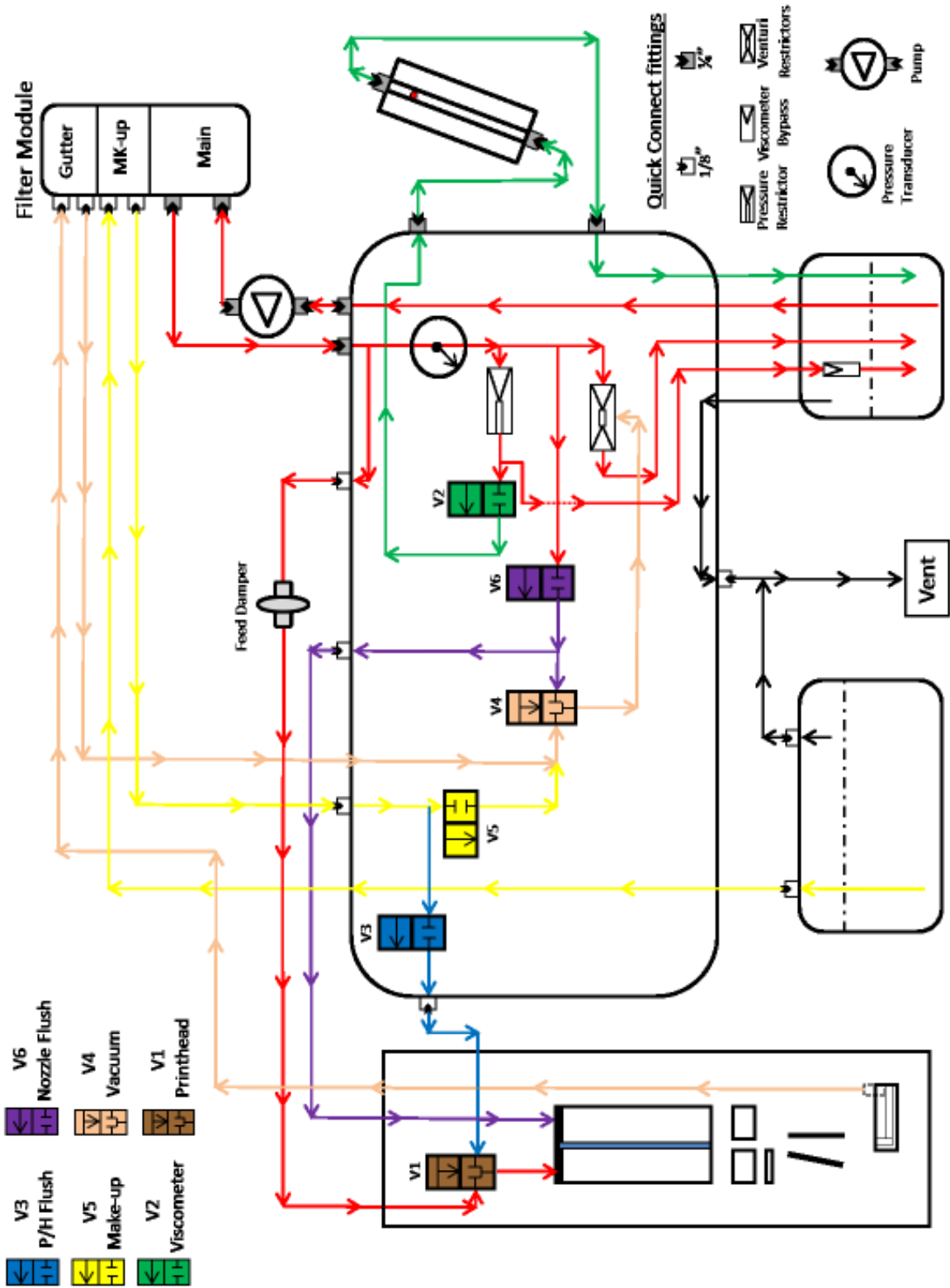

## Print Head

The image below shows the printhead with the covers removed. High pressure ink is forced through a nozzle located on the end of the Drop Generator as a continuous stream. The Resonator Probe in the Drop Generator vibrates and causes the ink stream (or Jet) to break up into a steady stream of droplets.

Droplet breakup occurs in the middle of the charge electrode while a precise negative voltage is applied to the drops to be printed. Next droplets pass through the deflection field where the charged drops are pulled from the stream to exit the printhead to land in a precise pattern on the substrate to form characters.

The deflector plates create a constant electric field which deflects the charged ink droplets.

Uncharged droplets are collected in the gutter to be returned back to the Ink System to be reused.

***NOTE:*** Further troubleshooting/testing and adjustments explained in **SECTION 9 CALIBRATION**

The following components are housed within the Printhead enclosure:

1. Drop Generator
2. Nozzle Plate
3. Charge Electrode and Strobe
4. Phase Detector
5. Deflector Plates
6. Gutter
7. Gutter Sensor
8. Printhead Valve
9. Phase Circuit Board
10. Printhead Cover Sensor
11. Printhead Temperature Sensor (behind Drop Generator)

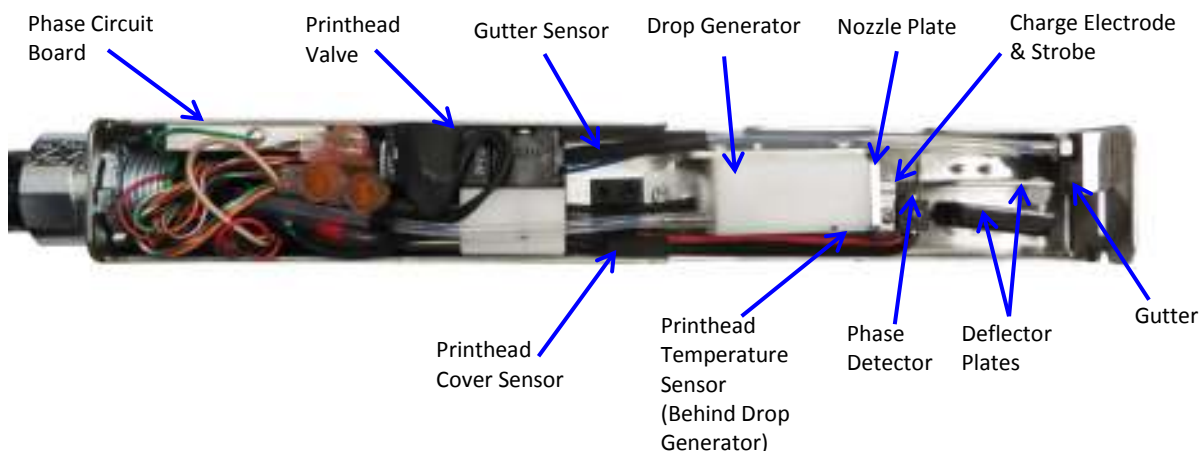

## Drop Generator

The Drop Generator contains the Resonator Probe and temperature sensor. The Resonator probe oscillates to break the stream into uniform drops. Each Printhead is calibrated with the modulation voltage, band, charge, and pressure at the time of manufacturing, which is noted on the Controller Settings Label.

The modulation voltage, Ink viscosity, band, and ink pressure must be correct, ensuring the drop breakup point occurs in the charge electrode slot. If the drop breakup point occurs outside the slot, incorrect charging of the drops will occur.

## Nozzle

The Nozzle helps determine the drop size printed.

## Charge Electrode and Strobe

The breakup caused by the Drop Generator is calibrated to occur within the Charge Electrode slot. The Charge Electrode applies a charge to drops required for printing. Those drops that do not receive a charge will be returned to the Ink system for re-use through the gutter.

A strobe LED situated underneath the Charge Electrode allows the drop breakup to be viewed with a 10x or greater magnifying eyeglass.

## Phase Detector

The Phase Detector provides feedback that the drop charging is occurring correctly. The drop charge timing is critical to the operation; thus a feedback circuit is required to ensure this timing to maintain optimum print quality.

## Deflector Plates

The Deflector Plates generate an electrostatic field. This field deflects drops by the amount of charge they received at the charge electrode. Drops with a greater charge will be deflected further than those with a lower charge. Drops that do not contain a charge will not be deflected, passing instead through the electrostatic field to the gutter for re-use by the Ink system.

## Gutter

The printhead Gutter collects non-charged droplets and delivers this reclaimed Ink back to the Ink system for re-use. In the event the gutter is not collecting non-printed drops during the printing process, the Gutter Sensor will detect a fault and display an error screen.

## Printhead Valve

The Printhead Valve is a three-way valve that:

- Turns the Jet on / off
- Opens and closes to allow air to be purged from the Printhead at startup.
- Opens during a “Backflush” sequence to allow solvent to be pulled in the reverse direction through the nozzle to clear/remove debris or obstructions and during the “Stop Flush” sequence at shutdown.

### **Phase Circuit Board**

The Phase Circuit Board receives a low voltage signal from the Phase Detector, then amplifies and digitizes this signal for processing.

### **Printhead Cover Sensor**

The Printhead Cover and Printhead Body contain an integrated intrinsically sealed switch to turn off the charge voltage (up to 300V), and deflector voltage (up to 8KV). These voltages are required to print; thus the Printer will not print without the Printhead Cover in place. The switch is integrated with the Printhead Body, and the magnet is integrated with the Printhead Cover. The cover switch will toggle an icon on the main screen to indicate if the Printhead is open or closed.

### **Printhead Temperature Sensor**

The Printhead contains a temperature sensor to ensure the flammable fluid temperature ignition point is not exceeded. Set well below the ignition point, if the temperature at the Printhead exceeds 60° C, the Printer will shut down automatically. In addition, an error screen will be displayed.

## SECTION 2: GRAPHICAL USER INTERFACE

### CONTENTS

	Page
Introduction.....	2-2
Home Screen .....	2-2
Printer Status and Controls: .....	2-3
(1) Status Bar .....	2-3
(2) Menus Tab .....	2-3
(3) Navigation Tool Bar.....	2-4
(4) Function Toolbar .....	2-4
(5) Edit Button .....	2-5
(6) Help Button .....	2-5
Menu Screens .....	2-6
(1) Home Screen .....	2-6
(2) Messages.....	2-7
(3) Status.....	2-7
(4) Service .....	2-8
(5) Properties.....	2-8
(6) Security.....	2-9

## Introduction

The touchscreen GUI provides a simple intuitive interface for controlling the printer. It follows the same familiar structure as previous generations of Citronix printers. The printer boots up to the home screen which provides quick access to the most commonly used printer features.

The GUI is now available in Red or Blue background colors and also has a large Alert banner available. These are selectable during the commissioning of the printer. For more details see Section 4-11 Installation and Commissioning (Commissioning Wizards).

## Home Screen

The home screen provides quick and easy access to the most commonly used statuses and printer functions. It is used to start and stop printing, adjust the print properties for the application, refill fluids and provide quick access to other top level menu items. These status and function items are shown below.

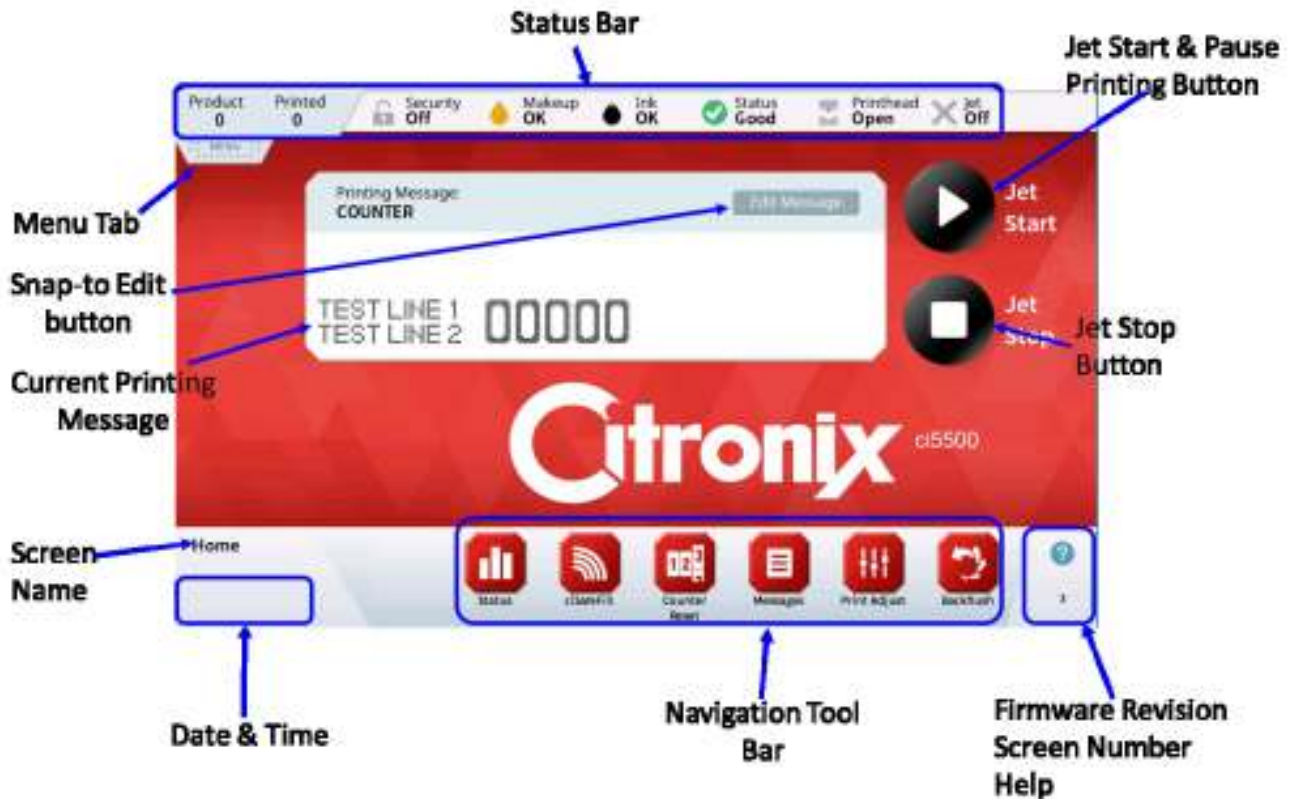

## Printer Status and Controls:

As you navigate through the GUI a number of different toolbars and control options become available. These consist of the status bar, menu tab, navigation toolbar, function toolbar, edit button, and help button which are described below and are used to view, change or edit depending on the task being undertaken. There can also be additional pages or buttons to provide additional change/edit options and these are shown by selecting the buttons shown below.



### (1) Status Bar

Important information on the health of the printer is provided in summary status bar. It contains information on the status of the items listed below. Additional information can be found in Section 4.

1. Print & Product Quantities
2. Security
3. Fluid Levels
4. System Health
5. Printhead
6. Ink System

### (2) Menu Tab

The ci5000 Series Printer has 6 icons that give the user quick access to each of the 6 task focused menu screens. The menu tab does not change and is available from the majority of the printer screens. Each icon directs the user to a task oriented root menu for the printer. These are described in more details below and consist of:

1. Home

- 2. Message
- 3. Status
- 4. Service
- 5. Properties
- 6. Security

### (3) Navigation Tool Bar

Each icon on the Navigation Toolbar takes the operator to a new screen. Screens are grouped based on their common functionality and organized like a directory tree. Pressing an icon takes one further down the directory tree and pressing the back button brings one up the directory tree.



### (4) Function Toolbar

The Function Toolbar is positioned on the right side of the screen only when additional functionality is needed for the screen. Function Toolbars are used to edit or adjust specific settings for each specific Menu screen. They will change depending on the Menu being viewed. Some will expand by pressing the Arrow button shown below. This reveals additional Function buttons.

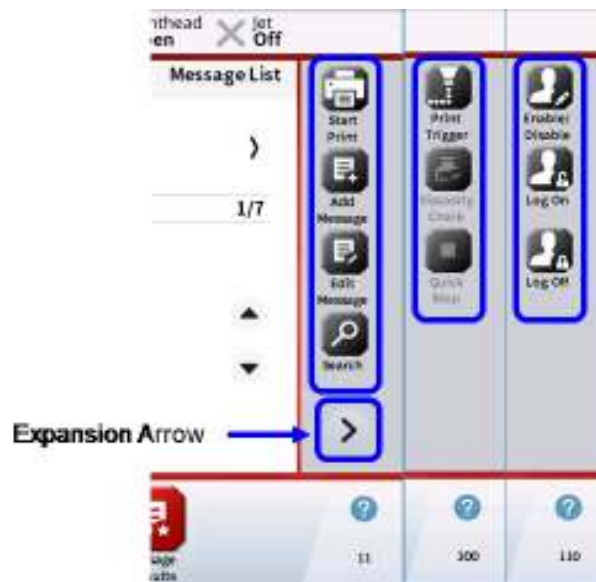

(5) Edit Button

[Edit]  buttons provide easy access to change setting or enable options.

When pressed, a keyboard will appear to allow the information to be entered or a list screen will appear to select from a list of options.



Keyboard



List

(6) Help Button

[Help]  button provides access to help information concerned with the current menu screen or option. Then this icon is pressed a brief description of that screen or option will be displayed.

An example is selecting the [Help]  button on the Main screen.



Using a smart phone with a barcode scanner the QR code can be scanned to take the user to a link where a more detailed description of the screen or if a fault more advanced troubleshooting techniques.



## Menu Screens

### (1) Home Screen

The home screen provides quick and easy access to the most commonly used statuses and printer functions. Each of the status and function items are described below.

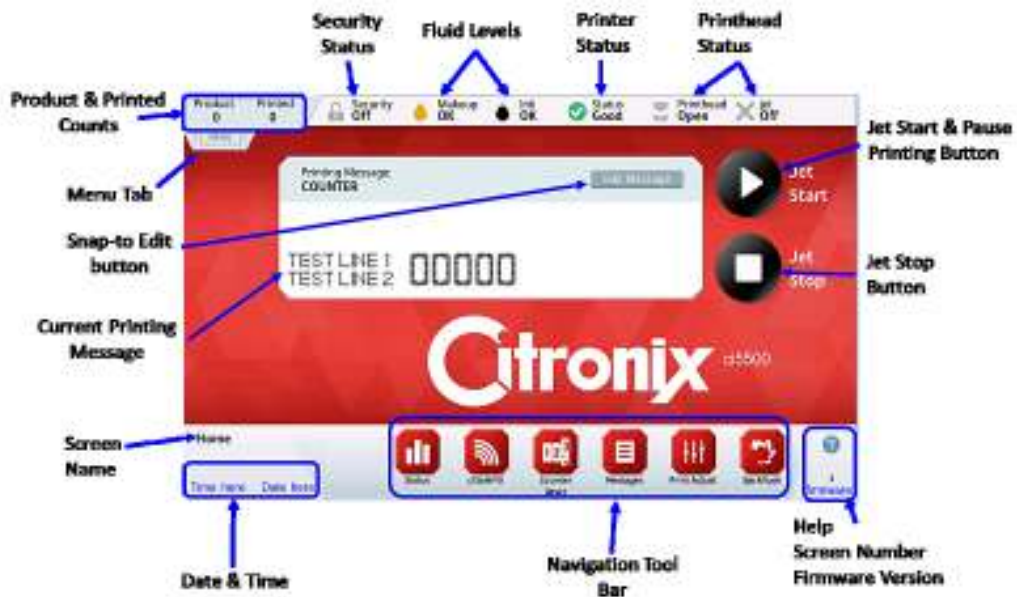

(2) Messages

The message edit screen is used for creating and editing messages by adding fixed and variable fields and formatting to a WYSIWYG message window. There is also a well-defined “Search” function that will search up to 30-character message names.



(3) Status

The status screens provide more detailed information on each of the printer’s subsystems. They are typically used by the service engineer during maintenance and repairs. They consist of the following screens.

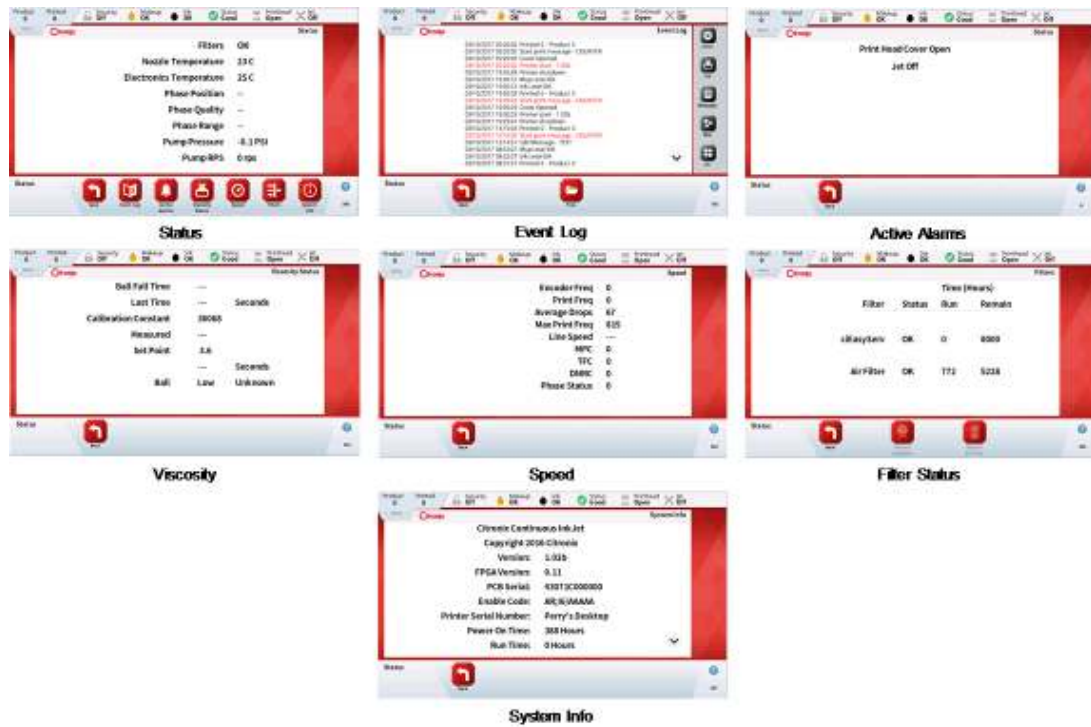

## (4) Service

The service screen gives access to various functions and settings for each of the printer's subsystems. It is typically used by the service engineer during maintenance and repairs. It consists of the following screens:



The system configuration screens.

The following controls are used to calibrate, test, and set printer specific settings and configurations. These settings should only be changed by a Citronix trained service engineer.

- |                |                    |
|----------------|--------------------|
| 1. Service     | 5. Run Pump        |
| 2. Flush Prime | 6. HV Trip Set     |
| 3. Override    | 7. Configure       |
| 4. Test Valves | 8. Advance Service |

***NOTE:*** Further troubleshooting/testing and adjustments explained in [SECTION 6 Cleaning and Maintenance/Service Routines](#)

## (5) Properties

The Properties screen is used during installation to configure a printer for a given production set up. It is used for setting up interfacing with accessories (such as photocells, encoders and beacons) and external communications (such as Ethernet or RS232). This is usually set up by the service engineer.

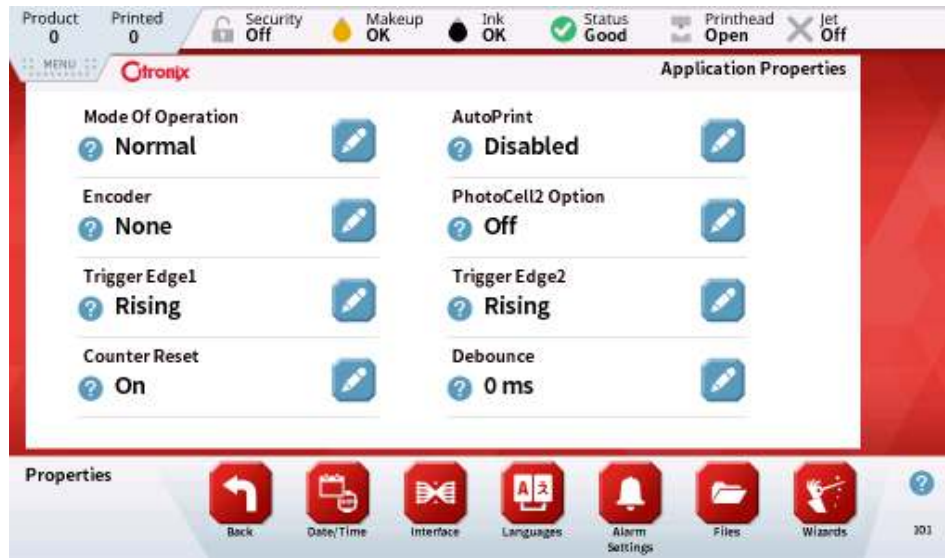

(6) Security

The Security screen allows select features of the printer to be disabled until a user with the correct privileges logs in. By default, Security is disabled. To enable Security, you must have at least one user with security privileges.

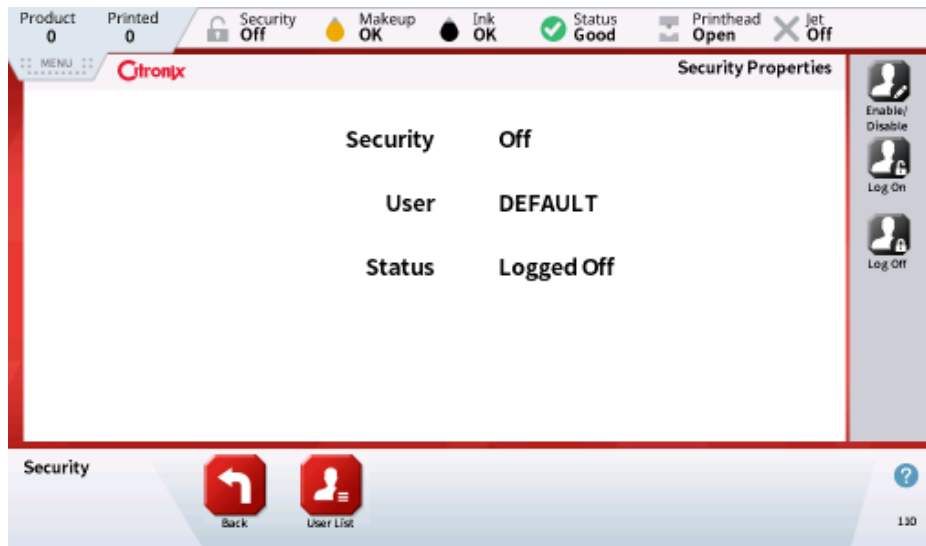

Function Tool Bars are used to edit or adjust specific settings for each specific Menu screen. They will change depending on the Menu being viewed. Some will expand by pressing the Arrow button shown below. This reveals additional Function buttons.

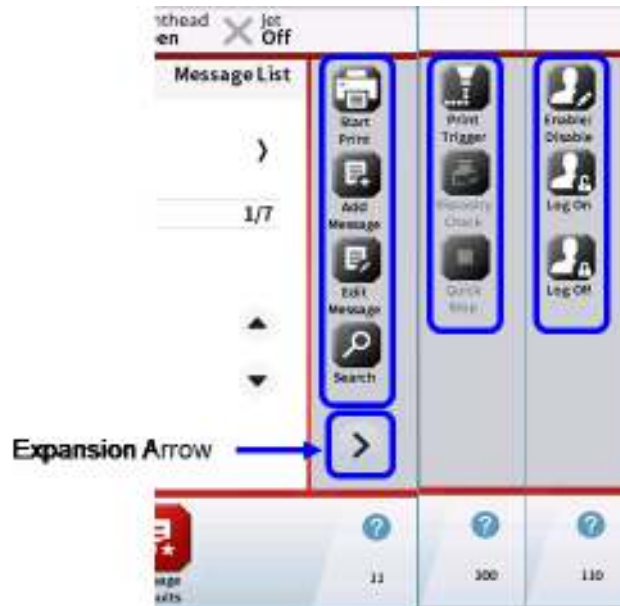

## SECTION 3: PRINTER OPERATION

### CONTENTS

	Page
Startup & Shutdown .....	3-3
Start up .....	3-3
Shutdown .....	3-4
Extended Shutdown .....	3-4
System Properties .....	3-5
Application Properties .....	3-5
Display Settings .....	3-7
Setting them System Date & Time .....	3-8
Setting Host Interface Properties .....	3-9
Changing System Language .....	3-10
Setting Alarms .....	3-11
Files .....	3-12
Security .....	3-22
Create Message .....	3-24
Message Fields .....	3-35
Text Fields .....	3-35
Autocode .....	3-36
Bar Code .....	3-43
Graphic .....	3-45
How to Use Microsoft Paint to Create Printable Graphics .....	3-47
Message Options .....	3-53
Graphic Utility .....	3-53
Message Sequence .....	3-53
Message Codes – External Message Select .....	3-55
Date Properties .....	3-56
Message Defaults .....	3-59
Edit Message .....	3-59

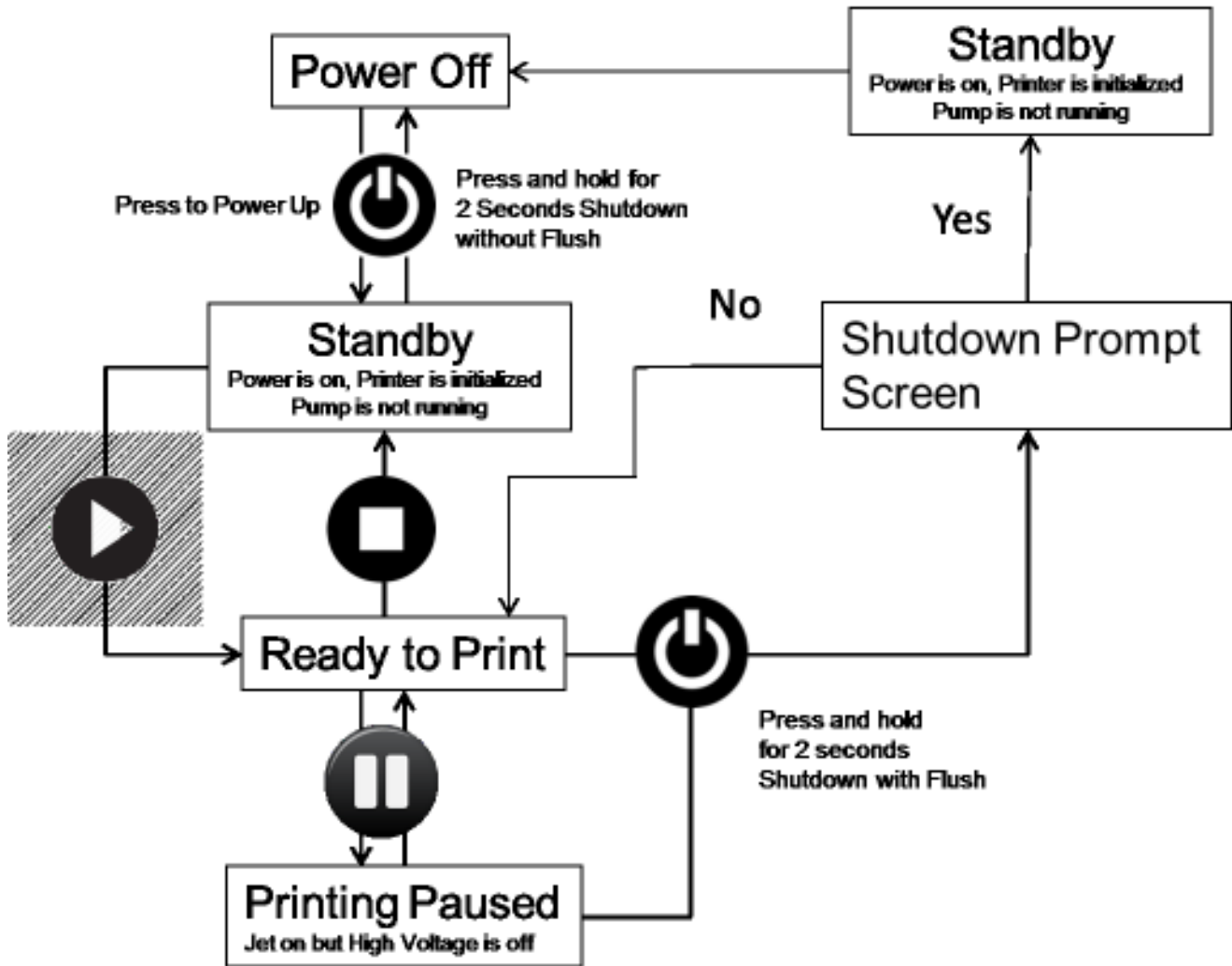

Message Store and Search .....	3-61
Selecting a Message to Print .....	3-62
Print Adjust Parameters.....	3-62
Drop Size .....	3-63
Print Quality (ciPrecisionPlus) .....	3-64
Delay .....	3-64
Width .....	3-65
Gap.....	3-65
Orientation .....	3-65
Bold .....	3-66
Height .....	3-66
AutoPrint Pitch .....	3-66
Repeat Printing.....	3-66
Add Ink and Makeup .....	3-67
Status .....	3-69
Status (Main) .....	3-70
Event Log .....	3-70
Active Alarms.....	3-72
Viscosity Status .....	3-72
Speed .....	3-73
Filters.....	3-74
System Info.....	3-75

## Startup & Shutdown



### Start up

Press and hold the [Power]  button located on the left-hand side of the printer for 2 seconds. After approximately 40 seconds, the printer will have fully booted up and is ready to start the jet. Press the [Jet

Start]  button and the Jet Status  (located in the top right corner of the screen) will change from “Off” to “Starting”. The Jet Start button will show a countdown in the lower left hand corner of the screen and the “Jet Start” wording will flash Black and White while the printer is starting.



In approximately 30 seconds the jet will be on, if the printhead cover is on, the Deflection Voltage will be turned on and the Jet Status will change to “Ready” (meaning ready to print).

Pressing the [Pause] button while the printer is ready to print will stop/inhibit any print signal(s) and the Jet Status will change to “Paused”.

Pressing the [Pause] button again will allow print signals and the Jet Status will change back to “Ready”.



## Shutdown

Pressing the [Stop] button will shut down the printhead. The printer will automatically flush the Nozzle Plate and Gutter Block and tubing. There will be a countdown shown in the bottom left hand corner of the Home screen and “Jet Stop” will flash Black and White. Once this has completed, the Jet

Status will change to “Off”. Power can now be safely turned off by pressing the [Power] button on the left side of the cabinet.

### Safe Stop:

Pressing the [Power] button while the printer is “Ready” to Print will cause a Prompt screen (shown below) to be displayed to confirm if the printer is to be shut down or not.



If Yes is selected, the printer to automatically perform a normal shutdown procedure (flushing the nozzle and gutter) then power off.

## Extended Shutdown

If the printer is to be shut down for up to 7 days, flush the gutter with the correct cleaning solvent during the auto-flush cycle to ensure the gutter is completely clean. Clean the rest of the print head as needed.

If the printer is to be switched off for longer than 7 days, or transported, the ink and make up should be replaced with cleaning solvent to prevent valve and nozzle blocking. This can be done by using the following process.

1. Use the Ink and Makeup Change procedure (see Section 6 “Changing Ink, Makeup or Ink, Makeup Tank (Ink Refresh)”) to remove the Ink and Makeup from the Printer. The Makeup can be used as a cleaning solution for the flush process.
  2. Pour roughly 500ml of Cleaning Solvent or Makeup in the Ink tank; reinstall the Ink tank, leaving the Manifold loose.
  3. Turn ON the power.
  4. Press the Menu Bar Dropdown and select the [Service] button.
  5. Select [Overrides] and then select all of the “Overrides”. This will ensure no errors will inhibit this process.
  6. Start the Jet by pressing the [START] button on the main screen. This will flush the Printer of Ink.
  7. Press the [STOP] button on the main screen to stop the Printer after 2 minutes.
  8. Repeat steps 1 through 6 three times for long term storage.
  9. Remove and dispose of the solvent in both Ink and Make-up Tanks (according to local regulations). Reinstall the tanks and leave the tank adapter loose. The intent is to empty the system of all fluids.
  10. Follow steps 3 through 6.
- The printer is now ready for Long Term storage.

## System Properties

### Application Properties

Setup screen for specific application properties

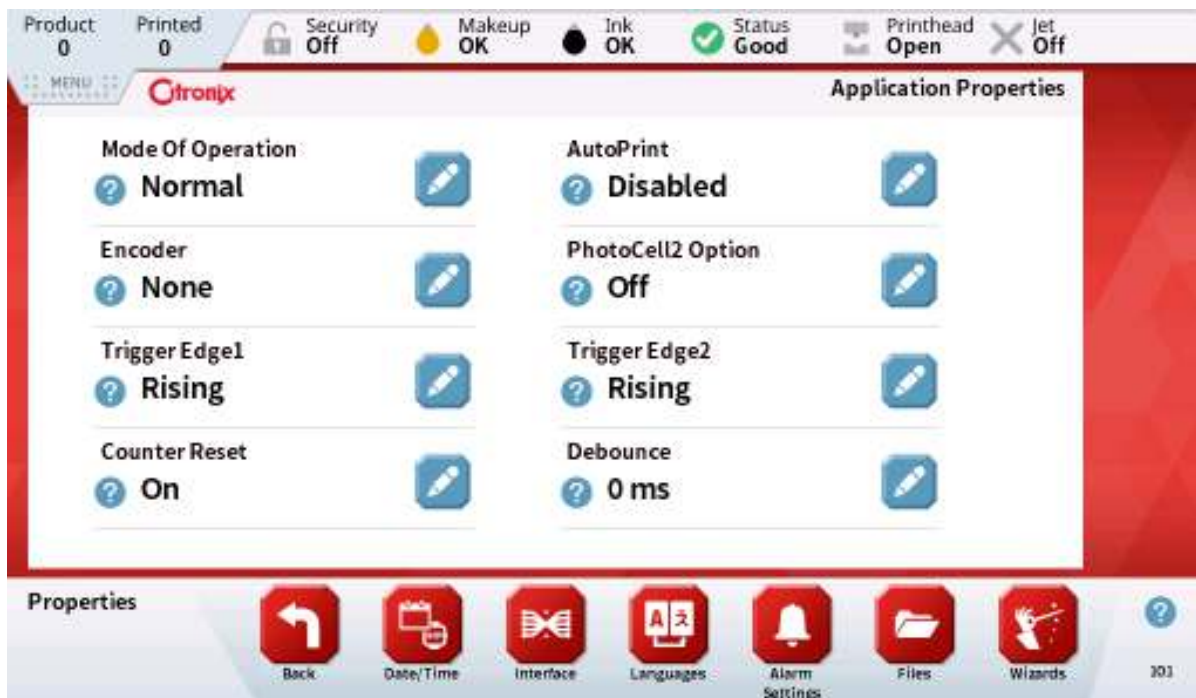

Settings	Action	Options
Mode of Operation	Sets the operation of the system for the application – see details below.	Normal, Measurement, Message Sequence, Message Code, One for One.
Encoder	Sets whether a shaft encoder is used or not	None, External, Internal PC1, or Internal PC2
Trigger Edge 1 Trigger Edge 2	Sets edge of print-go signal to begin printing	Rising or Falling
Counter Reset	Allows counters to reset upon message selection or retain last count	On, Measurement, Midnight, Rollover, Global or Off
AutoPrint	Allows the ability to print continuously. Use Delay to separate the distance between prints.	Enabled or Disabled.
Photocell 2 Options	Allows the use of a second PhotoCell to reset or increment one or both counters or reverse the message	Reset Counter 1, Reset Counter 2, Reset Msg Counters All, Reset Total Counter, Reset Counter 1 Inc Counter 2, Increment Counter 1, Increment Counter 2, Increment Counters All, Message Left/Right, Message Up/Down, Message Mirror-Down, Print Trigger, Print Enable, Jet Off, Jet In/Off, Reset Counter All, Reset Counter 1/2, Increment Counter 1/2, or Off
Debounce	Sets photocell 1 & 2 debounce time in milliseconds. Useful for filtering secondary electrical signals given by mechanical relays.	0 – 99 ms

### **Photocell 2 Option**

The Photocell 2 connection can be used to alter certain items in the Printer. These options fall into two categories – Message Counters and Message Orientation. Photocell 2 should be triggered to effect these changes before Photocell 1 is triggered to start the print.

The normal operation of a Message Counter is for the Photocell 1 connection to increment both Message Counters as it triggers a print of the current message. This may be altered with certain options of Photocell 2. These are:

- Reset Message Counter 1.
- Reset Message Counter 2.
- Reset Message Counters 1 and 2.
- Increment Message Counter 1.
- Increment Message Counter 2.
- Increment Message Counters 1 and 2.

When a selected Photocell 2 option is used for only one Message Counter, the other Message Counter will operate normally.

Photocell 2 has three options to set the orientation state of a message. These options are used when the Printhead is transported across a product, first in one direction and then in another. These options are:

- Set Message Left/Right
- Set Message Up/Down
- Set Message Mirror Down

Photocell 2 does not toggle the orientation; rather, it sets the orientation. The state of Photocell 2 needs to be set and held until the Photocell 1 trigger starts the printing of the message.

After installation, if the printing is the opposite of what is desired, the Trigger Edge 2 parameter can be changed and this will flip the printing to the correct orientation.

### Mode of Operations Defined:

**Normal mode** is the common mode of operation. A Message is selected to be printed and the same Message prints on all products.



**Measurement mode** is the setting used to mark the measurements on a product. When the photocell is blocked by a product and the encoder is turning, the counter counts up. When the photocell is unblocked, the counter is reset and ready for the next product.

**Message Sequence** uses a list of Messages to be printed. Each photocell trigger will switch to the next Message in the list. The list will wrap from the bottom back up to the top. There may be up to 20 Messages in the list. There is only one Message Sequence stored for use.

**Message Codes** uses a six-line connector to signal a binary number from 0 to 255. This number indicates the Message Code of the Message to be printed. When Message Code mode is selected, each Message may be assigned a Message Code. There is no transmission of data for this mode. There are four lines of input that are read at the time of the photocell trigger.

**One-For-One mode** is designed for applications that need to print new data on each product. The new data must be sent by an external computer for each print. This mode of operation guarantees that the same data will not print twice. If new data does not arrive before a photocell trigger, the photocell is ignored and nothing will print on the product.

### Display Settings



From the Home screen, press the [Menu Bar]  Tab to open the Menu bar then select the [Properties]  button on the Menu Bar. The Navigation Tool Bar will display the following:

1. Date & Time
2. Interface properties
3. Languages
4. Alarm & Relay Settings
5. Files
6. Wizards



## Setting the System Date & Time

From the Home screen, press the [Menu Bar] Tab to open the Menu bar then select the [Properties]



 button on the Menu Bar. Press the [Date/Time]  button in the Navigation Tool Bar to set the printer's:

1. Date & Time
2. Date Format
3. Time and Date Delimiters
4. Network Time settings (if used)

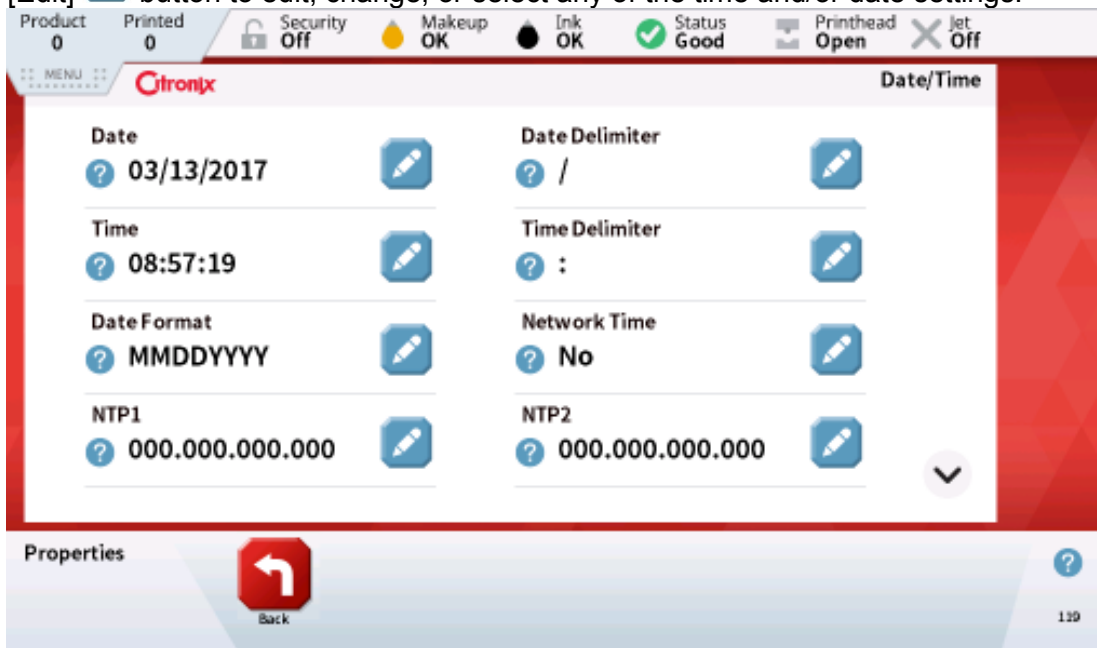
Using the [Edit]  button to edit, change, or select any of the time and/or date settings.



1. Setting/changing the Date & Time



Press the [Edit]  button, using the number keypad enter/change the date then press the [Save]  button.

***NOTE:*** ensure the delimiter is inserted between the month, day, and year when editing the date. In the example below, the “/” is being used.



## 2. Setting the Date Delimiter

The Delimiter is a separator between the month, day, and year. This can be any single character, such as a /, -, : and can even be a letter or number.

To set/change the delimiter, press the [Edit]  button, from the standard keyboard press the character needed and then press the [Save]  button.

## Setting Host Interface Properties

If connecting a connection for Host Communication Interface using RS232 or Ethernet. The following will help setup the printer to send and receive commands.

**NOTE:** a complete Section focusing on the Communications Interface for the Citronix Printer can be found in Section 7 “Communications”.

From the Home screen, press the [Menu Bar] Tab to open the Menu bar then select the [Properties]

 button on the Menu Bar. Press the [Interface]  button in the Navigation Tool Bar to select the printer's:

1. Serial Interface
2. Internet Interface

### 1. Serial Interface:

The RS232 or Serial interface can be used to:

- Backup and restore all Graphics, Messages and Properties of the Printer.
- Perform commands to select messages and update text in messages.
- Perform commands to control the Printer.
- Receive acknowledgements of Photocell trigger, Print Ready and Print Complete.
- Receive warnings/errors.

### 2. Internet Interface:

The Ethernet Web interface can be used to:

- View and control the Printer via a Web interface.
- View and download event logs.



- Update firmware on the Printer.
- Backup and restore all Graphics, Messages and Properties of the Printer.
- Upload/Download Language files to the Printer.
- Upload Graphics to the Printer.
- Upload Font files to the Printer.
- Upload IME files to the Printer.
- Upload Keyboard image files to the Printer.

The Ethernet interface can be used to:

- Backup and restore all Graphics, Messages and Properties of the Printer.
- Perform commands to select messages and update text in messages.
- Perform commands to control the Printer.
- Receive acknowledgements of Photocell trigger, Print Ready and Print Complete.
- Receive warnings/errors.

## Changing System Language

From the Home screen, press the [Menu Bar] Tab to open the Menu bar then select the [Properties]

 button on the Menu Bar. Press the [Languages]  button in the Navigation Tool Bar to select the printer's:

1. Operating Language
2. Printed Fonts

In this screen there are 3 columns showing the Language, Font, and Text. The Number beside each shows the number of that category that have been downloaded.

Example: **Language(26)** this shows that 26 languages have been loaded onto this printer.

To change/select a Language, first select/highlight the Language then press the [Select Language]  button. This will change the operating Language of the printer.





Individual Fonts can be viewed or deleted by pressing the [Font] button. A Language must be highlighted first.

This will display all of the fonts available for that Language. They can be deleted (if not needed) by highlighting the Font and pressing the [Delete One Font]  button.

## Setting Alarms

This screen allows the setup of alarm 1, alarm 2, alarm 3 and relay functionality (not available in the ci5200).

From the Home screen, press the [Menu Bar] Tab to open the Menu bar then select the [Properties]  button on the Menu Bar. Press the [Alarm Settings]  button in the Navigation Tool Bar to select the printer's:



1. Alarms 1 Function
2. Alarms 2 Function
3. Alarms 3 Function
4. Relay Function (not available in the ci5200)



For each Alarm/Relay, there are 3 state functions that need to be set.

1. What kind of alarm (None, Failure, Warning, Print Ready)
2. Normal State (Off, On, Flashing)
3. Active State (Off, On, Flashing)

Normal State is the state when there are no Fault or Warning.  
Active State is the state when a Fault or Warning has occurred.

Each setting can be changed or setup by pressing the [Edit]  button and selecting from the list, then press [Save] .

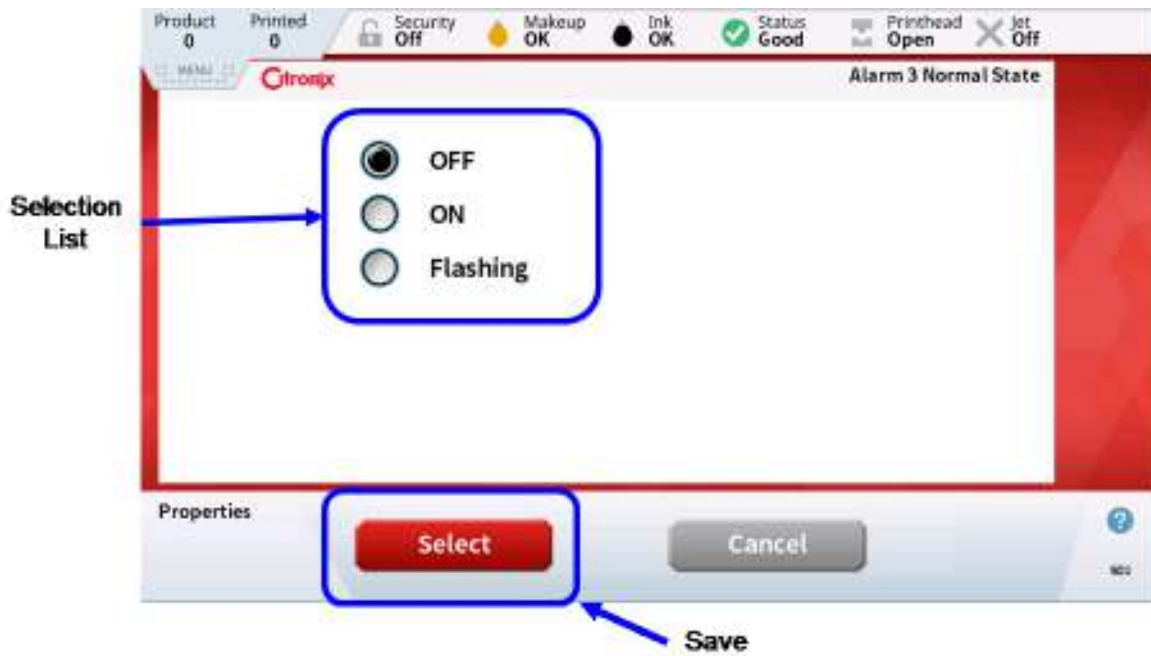

## Files

The Files screen allows a PC Free way to perform all upgrading and restore functions by using an on Board SD card or by plugging in a USB into the USB port on the CPU board.

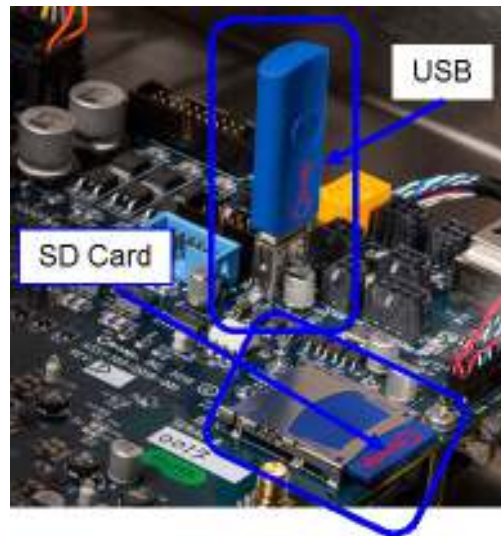



From the USB or SD Card you can:

1. Update Firmware
2. Install Fonts
3. Install Languages
4. Install IME Keyboards
5. Backup the printer
6. Restore the printer from a previous backup

7. Install bitmaps/logos
8. Backup the Event Log

When using a USB;

First plug it into the printer. This allows the printer to download onto the USB a file structure. This is an automatic process. To do this;

1. insert the device (USB or SD Card) into the proper slot
2. Navigate to view the device by selecting [Properties] 
3. Select [Files] 

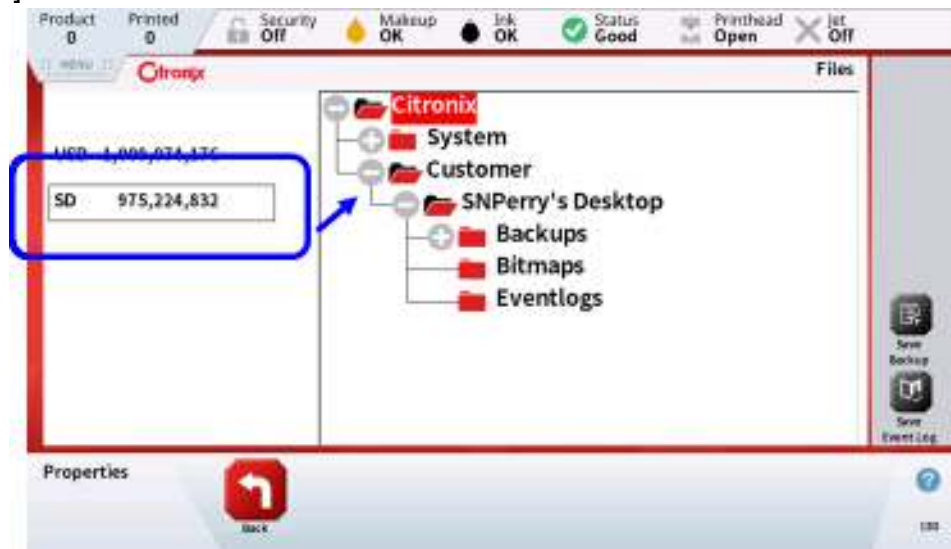

4. Select/press the USB device

Note: this will take a few seconds for the printer to read and write the file structure to the device. When this is completed the structure will be displayed on the screen

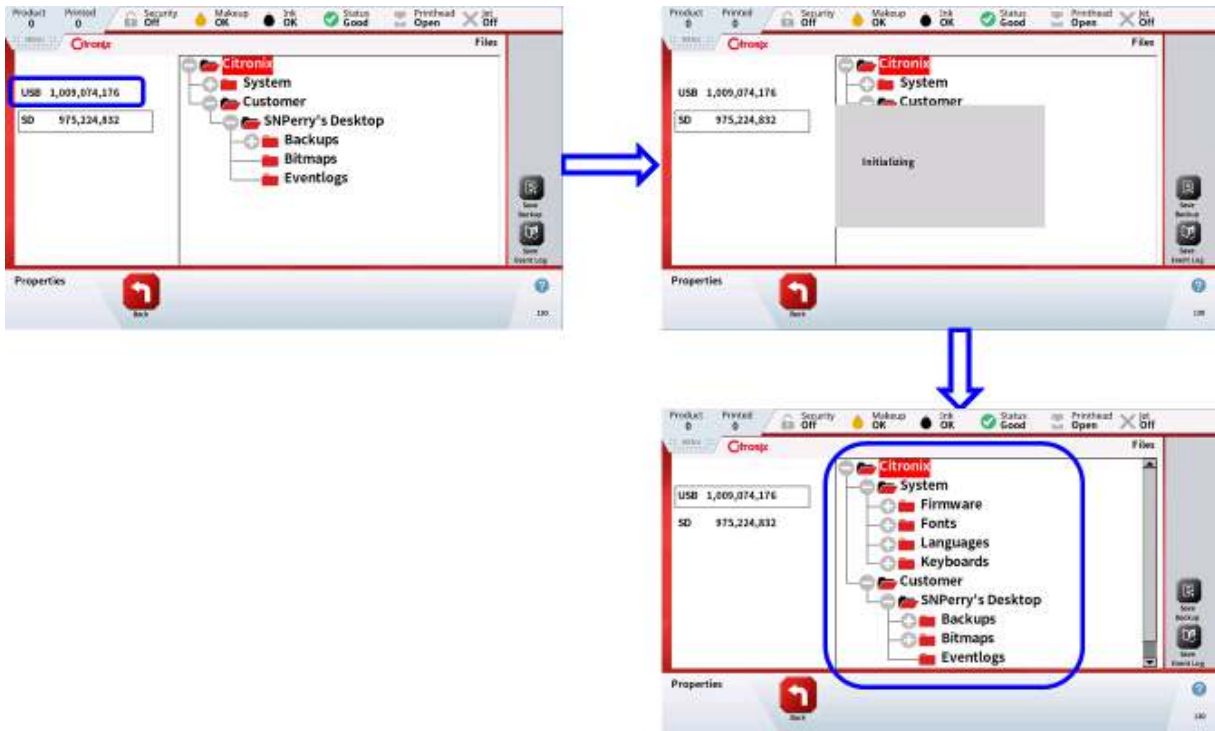

5. Now the USB device can be removed and plugged into a PC to download the file into the appropriate folder.

On the USB there is a Citronix file with 2 sub-files (System & Customer).



System is used for all system files

1. Firmware
2. Fonts
3. Language
4. Keyboards







Customer are printer files (printer specific) and consist of;

1. Backup
2. Bitmaps
3. Event Logs

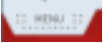
There can be multiple Customer files on 1 USB if installed onto multiple printers. This allows multiple printer files to be stored onto 1 USB

## **(SYSTEM File)**



### **Upgrading Firmware:**

1. Insert the USB into a printer and have the File Structure installed (as mentioned above).
2. Remove the USB from the printer and insert into any PC.
3. Navigate to the USB, open the System File Folder, then open the Firmware Folder
4. From the PC, copy and then paste the newest firmware into the Firmware folder on the USB.
5. Close and remove the USB from the PC and plug into the USB port on the CPU Board
6. Press in sequence, the [Menu dropdown] , [Properties] , [File]  buttons to navigate to the file screen.
7. Select the USB by pressing the letters USB on the left of the screen.
8. A screen will display “**Initializing**”, and after a few seconds the USB will be highlighted and the file structure displayed
9. In the File Menu screen, Press the [Plus]  symbol next to the “System” folder to open the folder
10. Next open the “Firmware” folder by pressing the [Plus]  symbol
11. Next Highlight the actual file and then press the [Install Firmware]  button in the Function Tool Bar to download the firmware to the printer
12. There will be a confirmation screen displayed to confirm (Yes or No) if you want to proceed and install the firmware. Selecting Yes and this will start the upgrade
13. There will then be a screen displaying “**Installing**” while the firmware is downloading
14. This will take approximately 30 seconds
15. When the download is complete, the printer will automatically close the screens to the Home screen and then reboot.
16. When the printer reboots, note the firmware has been upgraded in the bottom right of the screen.



### **Install Fonts:**

The 5000 Series has now a large enough memory that ALL Fonts, Languages, and Keyboard IME's will be installed on the printers before they leave Citronix, however if any are removed or otherwise need to be installed the following will give these instructions.

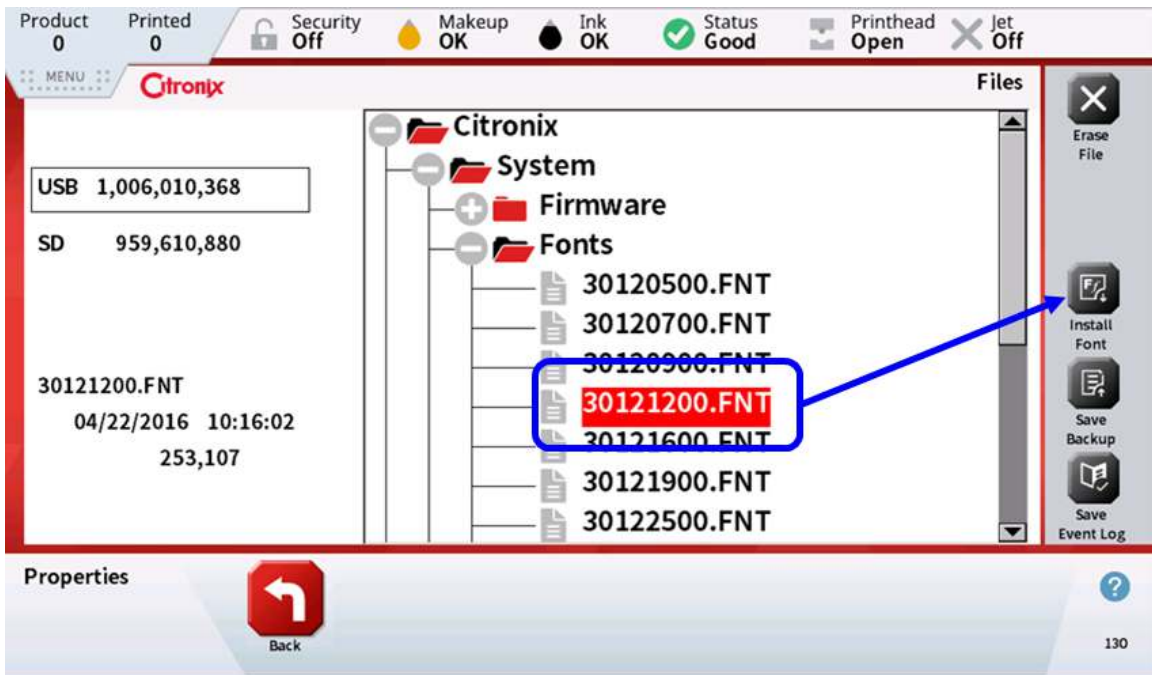

1. In the File Menu screen, Press the [Plus]  symbol next to the “System” folder to open the folder.
2. Open the “Font” folder by pressing the [Plus]  symbol.
3. All the fonts should be displayed (use the slide bar to the right to view more files).
4. Select the font needed and press the [Install Font]  button in the Function Tool Bar to download the font to the printer.
5. There will then be a screen displaying “**Installing**” while the file is downloading. This will take a few seconds
6. When the download is complete, the File Menu screen will be displayed again.

**NOTE:** This process must be done for each Font individually



### **Install Languages:**

As mentioned in the previous section, all of the Fonts, Languages, and Keyboard IME’s will be installed onto every Citronix 5000 Series printer. In case one was deleted or corrupted the following procedure will describe the reinstallation process using a USB.

1. In the File Menu screen, Press the [Plus]  symbol next to the “System” folder to open the folder
2. Open the “Language” folder by pressing the [Plus]  symbol.
3. All the Languages should be displayed (use the slide bar to the right to view more files)

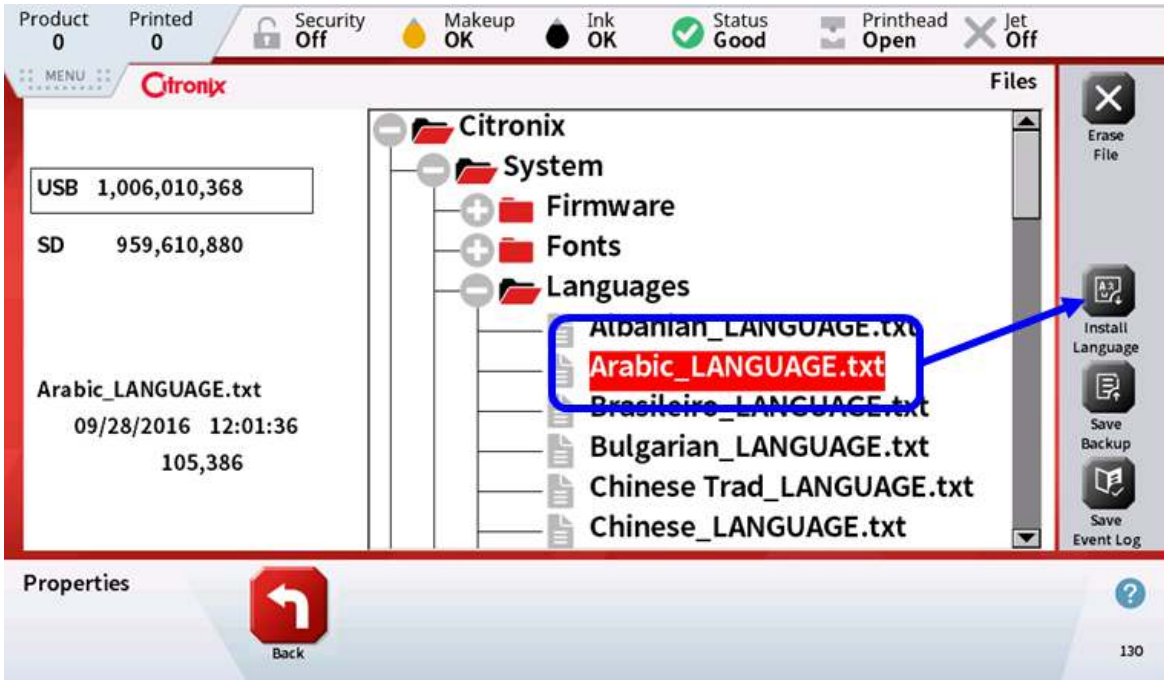

4. Select the Language needed and press the [Install Language]  button in the Function Tool Bar to download the Language to the printer.
5. There will then be a screen displaying “**Installing**” while the file is downloading. This will take a few seconds.
6. When the download is complete, the File Menu screen will be displayed again.

**NOTE:** This process must be done for each Language individually



### Installing Keyboard IME's:

As mentioned in the previous sections, all of the Fonts, Languages, and Keyboard IME's will be installed onto every Citronix 5000 Series printer. In case one was deleted or corrupted the following procedure will describe the reinstallation process using a USB.

1. In the File Menu screen, Press the [Plus]  symbol next to the “System” folder to open the folder
2. Open the “Keyboard” folder by pressing the [Plus]  symbol.
3. The Keyboard IME's should be displayed.
4. Select the Keyboard needed and press the [Install Keyboard]  button in the Function Tool Bar to download the Keyboard to the printer.
5. There will then be a screen displaying “**Installing**” while the file is downloading. This will take a few seconds.
6. When the download is complete, the File Menu screen will be displayed again.

**NOTE:** This process must be done for each Keyboard individually

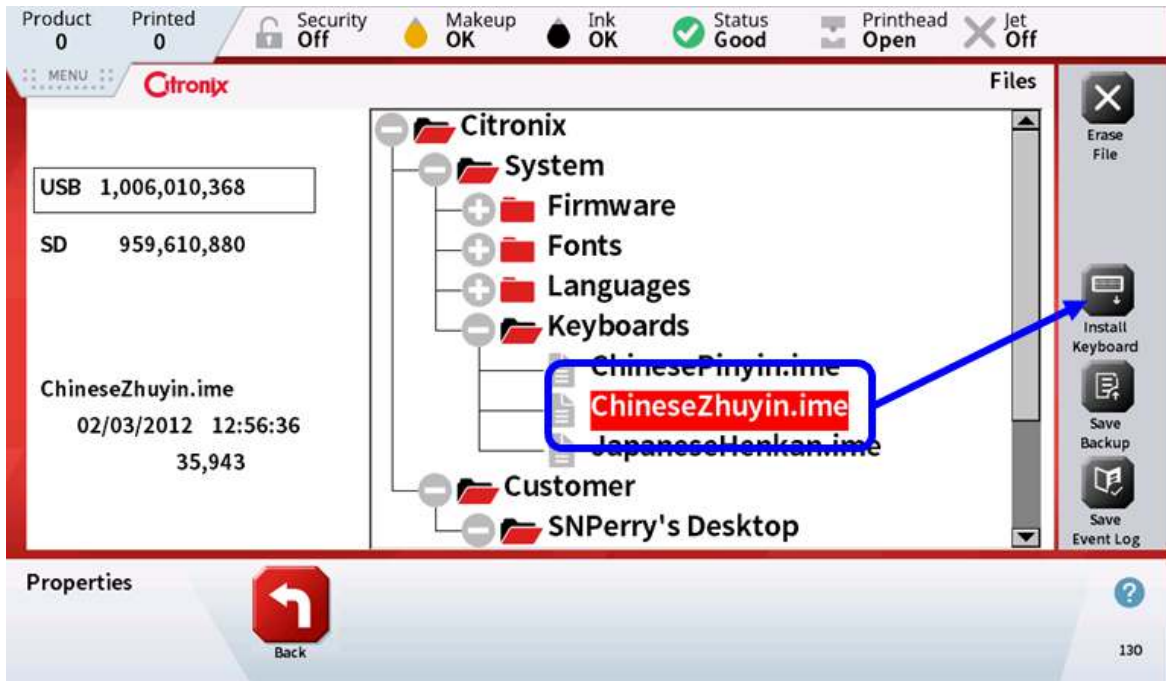

### (CUSTOMER File)

When using a USB, multiple printer files (Backup, Bitmaps, and Event Logs) can be stored onto one device (USB)

Each Printer's files will be save in its own "Customer" file with the printer's serial number as the Customer File name.

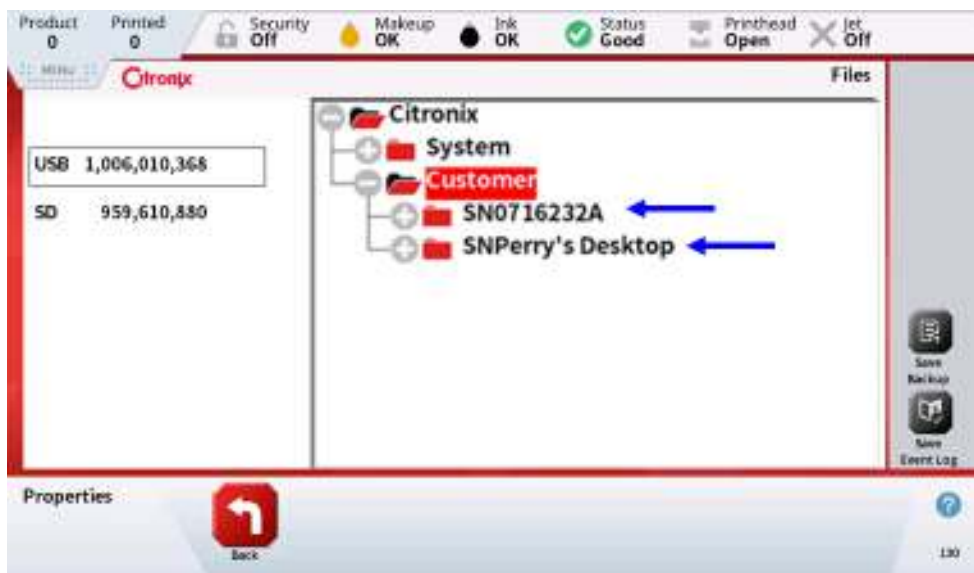

Each Customer file can be transferred to a PC by:

1. copying the complete Customer Folder
2. Opening the individual file and copying the actual Backup or Event Log files

Name	Date modified	Type
SN0716232A	1/6/2017 5:20 PM	File folder
SNPerry's Desktop	1/6/2017 12:38 PM	File folder

**Backup:**



On either the USB or SD Card (potentially both) the backup file will be automatically saved to the Printer's Serial number file (if there are multiple). The following procedure will save the Backup file.

1. Highlight the device the Backup is to be saved.
2. Press the [Save Backup]  button.
3. There will then be a screen displaying "**Writing**" while the file is downloading. This will take a few seconds
4. The file will be displayed as the year, month, date-time.bak

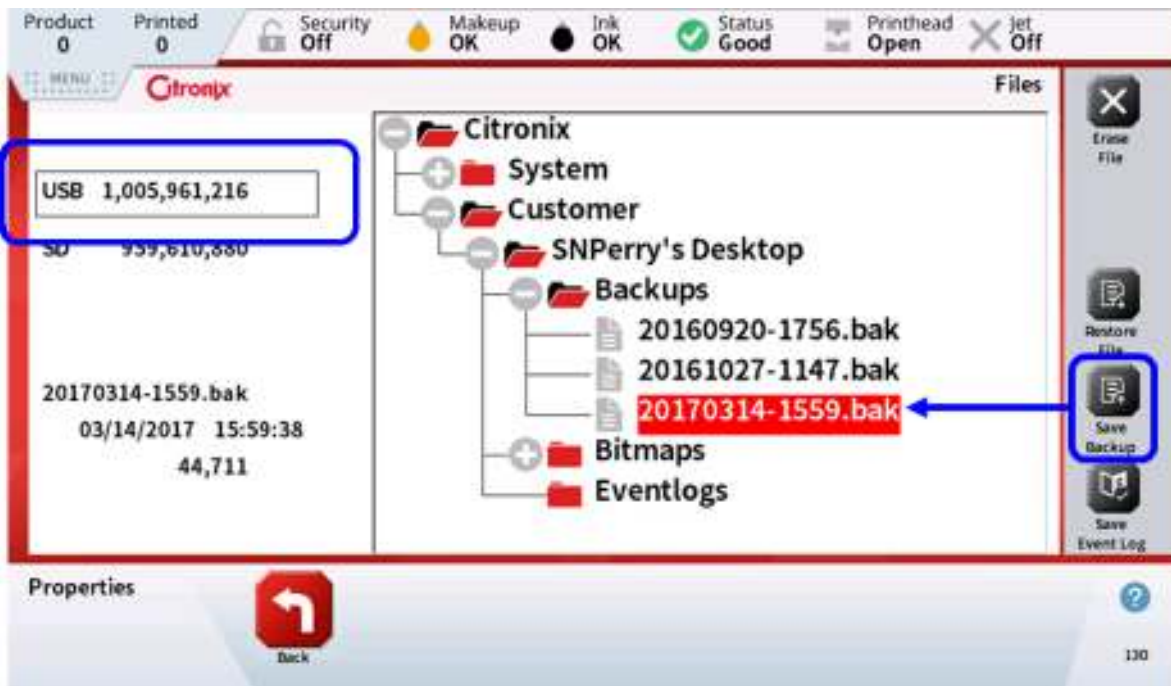
**NOTE:** *multiple backup files can be saved on each device (USB OR SD Card)*



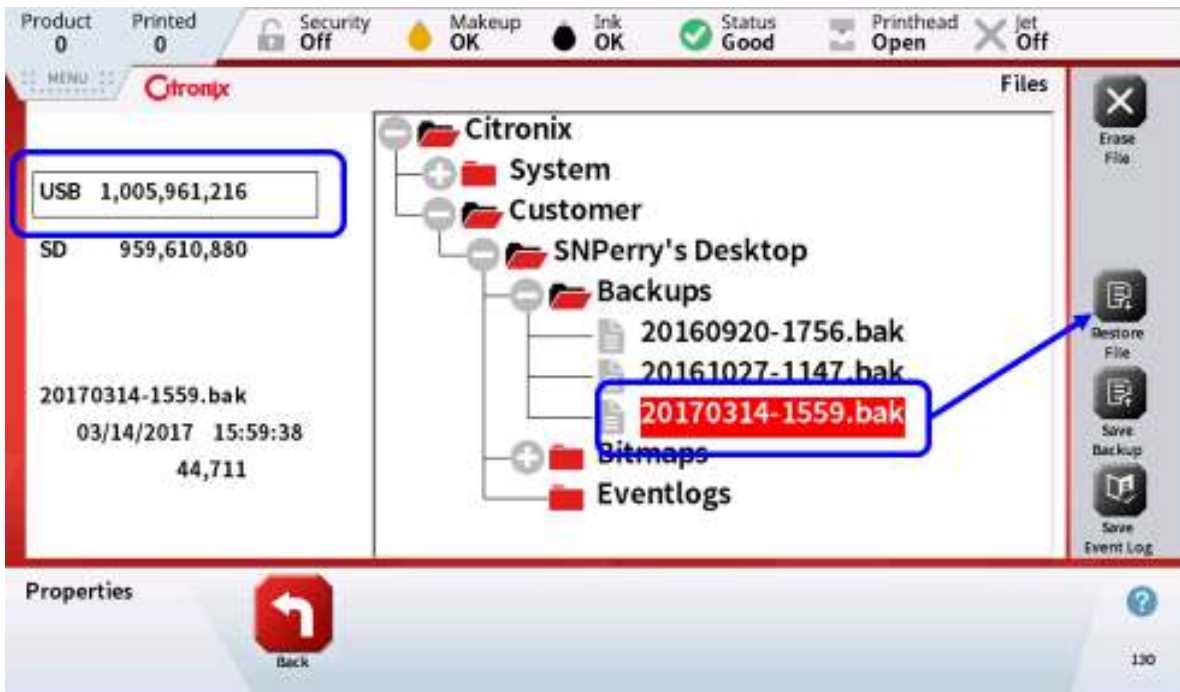

**Restore from a Backup:**

1. Highlight the device the Backup is stored.
2. Open the [Backups] folder by pressing the [Plus]  button and highlight the Backup file to be used.
3. Press the [Restore File]  button.
4. There will then be a screen displaying “**Restoring**” while the file is downloading. This will take a few seconds.
5. When the restore is complete the screen will display the previous screen



### **Transferring/Loading Bitmaps:**

Bitmaps are still created and saved as Monochrome Bitmaps, same as with the 3000 and older printers. Those older bitmaps can be loaded onto a 5000 Series printer using the USB.

1. Save all Bitmaps to be used in the Customer, Printer Serial Number, Bitmaps file (when inserting onto the USB).
2. Highlight the device the Bitmaps are stored.
3. Open the [Bitmaps] folder by pressing the [Plus]  button then highlight the Bitmap file to be used. Only 1 bitmap can be downloaded at a time.
4. Use the slide bar to the right to view more files.
5. Press the [Install Bitmap]  button.
6. There will then be a screen displaying “**Installing**” while the file is downloading. This will take a few seconds.
7. When the Bitmap has finished installing the screen will display the previous screen.

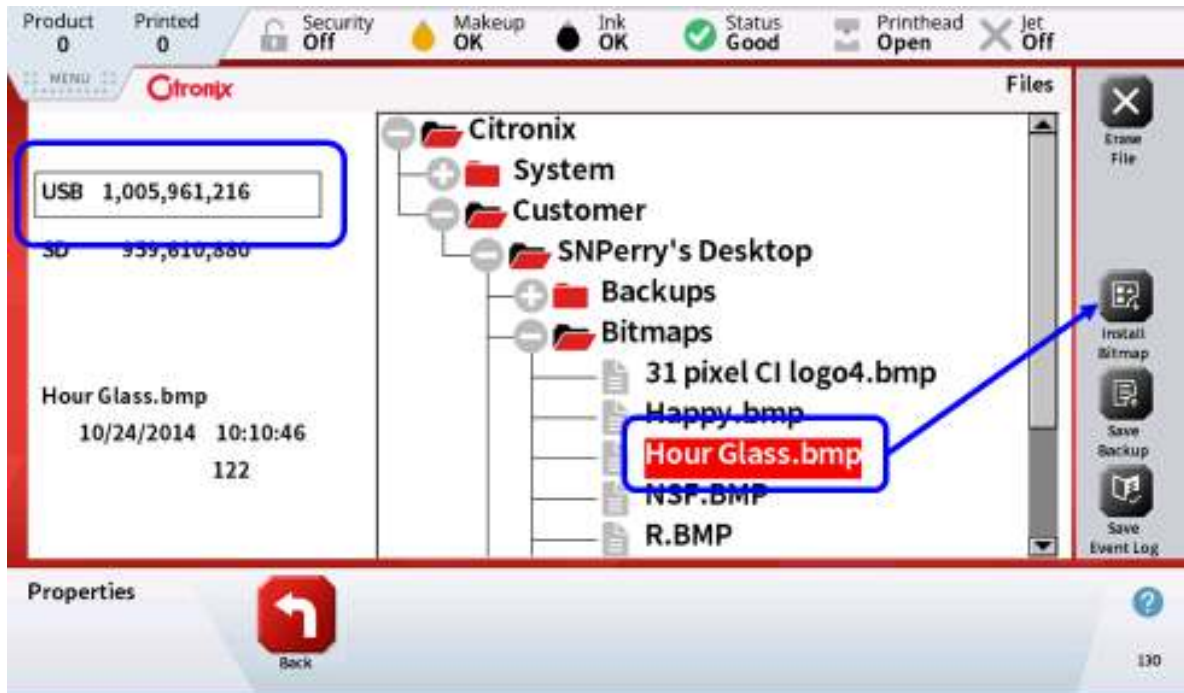

### Event Logs:

Event Logs are an important troubleshooting tool. Now an Event Log Backup file can be saved on board the printer using the SD Card **AND** taken with the technician by using the USB. Multiple Event Logs can be saved on each device (USB OR SD Card). The following is the procedure to save the Event Log

1. Highlight the device the Event Log needs to be stored (USB or SD Card). There is no further files need to be opened unless they need to be viewed. The Event Log will be saved only to that printer's Event Log File Folder.
2. Press the [Save Event Log]  button in the Function Tool bar.
3. There will then be a screen displaying "**Writing**" while the file is downloading. This will take a few seconds.
4. When the Event Log has finished Saving the screen will open displaying the file.

**NOTE:** the Event Log file name is the year, month, and Date followed by the time the file was taken.

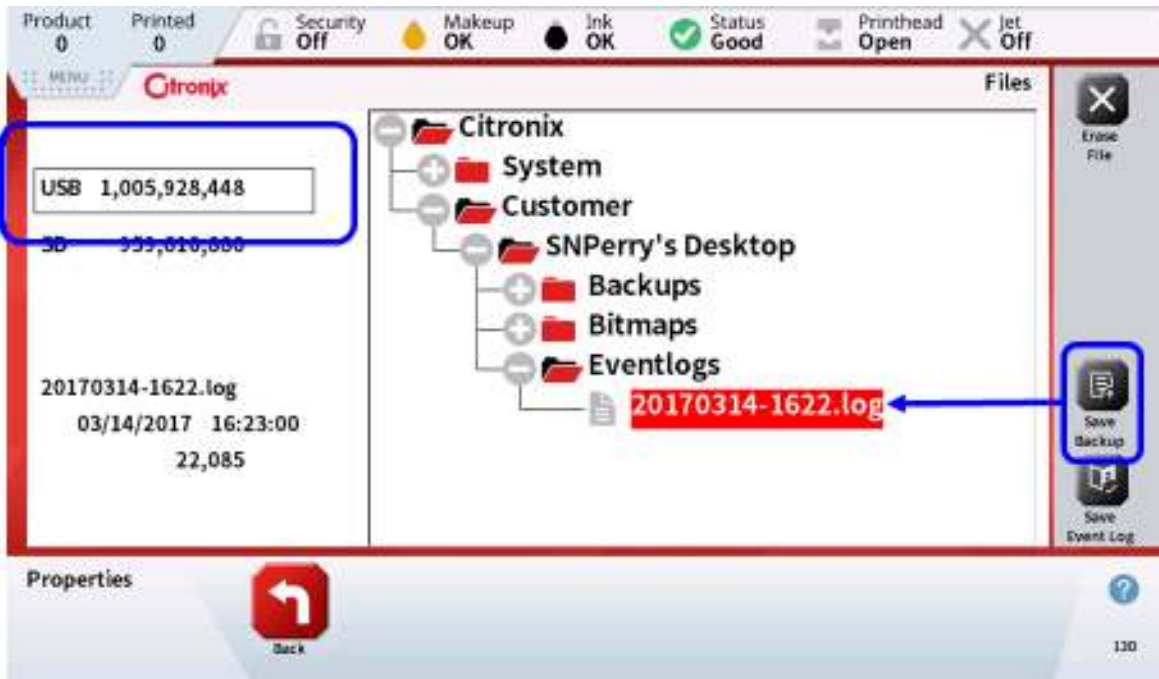



***NOTE:*** Once these Event Logs are transferred to a PC, they can then be emailed just as they are saved on the USB (a .log file).

## **Security**

The Security screen allows select features of the printer to be disabled until a user with the correct privileges logs in. By default, Security is disabled and the “DEFAULT” user is the current user being used. For example; an operator may only have the option of selecting a messages but not be allowed to edit messages, where a supervisory (or ADMIN) level will have the ability of editing messages and possibly more.

Admins are appointed at the time of installation and are given access to setup these different users and what functions or abilities are allowed to be carried out on the printer. To enable Security, you must have at least one user with security privileges.

### **Logging in as an ADMIN**

To log on as an ADMIN level User, first enter the Security Properties screen from the Home screen, by pressing the [Menu Bar]  Tab to open the Menu bar then select the [Security]  button.

Log on as the ADMIN by pressing the [Log On]  button. Enter the user name ADMIN and use ADMIN as the password (these are Default settings and can be changed after logging on). This will allow Admin privileges to add, edit, or delete Users.

***NOTE:*** User Names and Passwords are case sensitive!

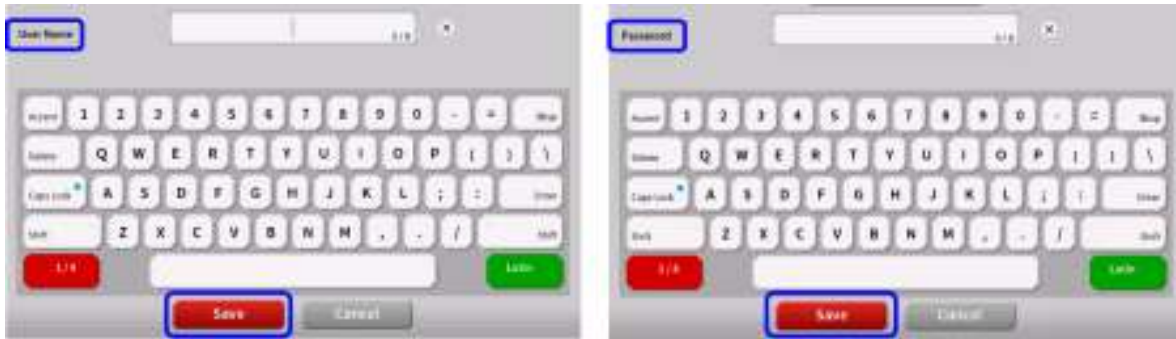



### Add/Change User and User Functions

Once logged in as ADMIN, press the [User List]  button found in the Navigation Tool Bar. A list of Users will then be displayed.



Using the 4 selections on the Function Tool Bar located on the right side of the screen, add, delete, edit, or copy a user.

When adding a new User, by pressing the  button, you will assign a User Name and then a Password. **REMEMBER these are case sensitive!** The edit each of the options by selecting Yes or No to allow or not allow that user access to that option or Menu. When done, press the [back]  button to save and exit the User Edit screen.





Note new OP (operator) User added to the User's list (below).



Users with Security rights are the only users able to Enable or Disable the Security feature.

## Create Message

Select the [Messages]  button in the Navigational Tool Bar at the bottom of the screen, OR you can also select the [Menu Bar] tab , then select the [Message] option  to take the user to the Message storage/creation menu.

Select the [Message Defaults]  button in the Navigation Bar.

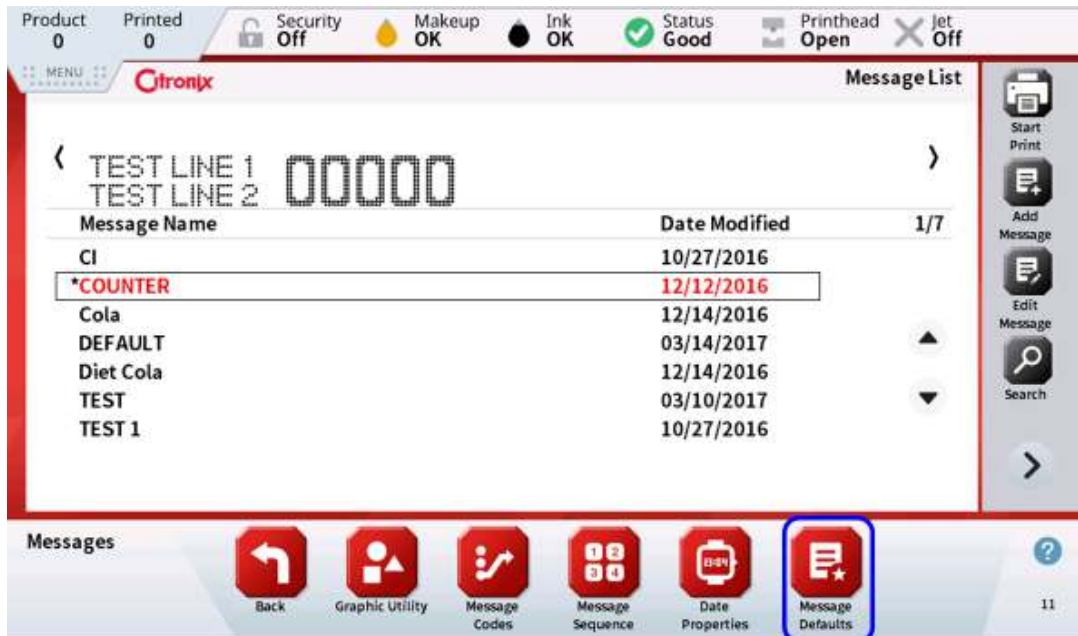

Set the default message settings from the lists. Please note there are 3 screens (shown below) to view/edit the different settings press the arrow button circled below.



Definition of the Message Default Settings:

1. Drop Size (**PixelPlus**) – Drop size used in a particular message. This can be different for each message created. **PixelPlus** unique software feature to change between small and large drops (60 and 75 micron) at a touch of a button. This also changes speed capability and is only available on ci5300/ci5500/ci5650 printer types.
  - a. Normal – 65 Micron drop
  - b. Macro – 75 Micron drop



2. Print Quality (**ciPrecisionPlus**) – is an incremental and smooth step control that enables an operator to fine tune the printed message for the best possible mix of speed and quality. This affects speed as the higher the print quality the slower the speed, the lower the print quality the faster the print speed. This is done by better drop control (drop charging) and use of guard drops.

This adjustment is adjusted in steps of 20 from 0 (lowest print quality/fastest speed) to 300 (highest print quality/slowest speed).

- Pixel - Sets number of printed vertical pixels. The Pixel setting should always match the maximum number of vertical printed drops being used. For all the options see the chart below.

**Example:** if printing 2 lines of 7 drop high characters, the selection should be either 2L or 16 not higher

**Example:**

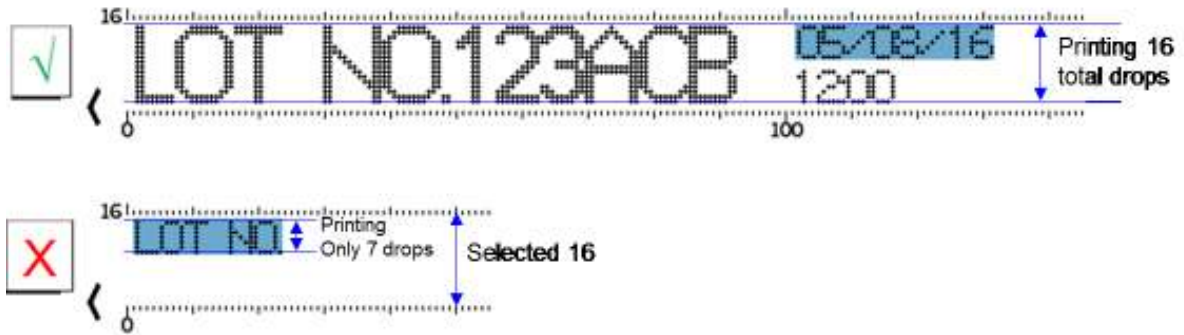

Pixel Settings:

The following pixel settings are available for selection:

Pixel	Description	Ci5200	Ci5300	Ci5500/ci5650
5	5 Dot Matrix	1 or 2 Line	1 to 4 Line	1 to 5 Line
7	7 Dot Matrix	1 or 2 Line	1 to 3 Line	1 to 4 Line
9	9 Dot Matrix	1 Line	1 to 3 Line	1 to 3 Line
12	12 Dot Matrix	1 Line	1 or 2 Line	1 or 2 Line
2L7	2 Lines of 7 Dot Matrix	2 Line	2 Line	2 Line
16	16 Dot Matrix	1 Line	1 Line	1 Line
19	19 Dot Matrix	N/A	1 Line	1 Line
3L7	3 Lines of 7 Dot Matrix	N/A	3 Line	3 Line
25	25 Dot Matrix	N/A	1 Line	1 Line
31	31 Dot Matrix	N/A	N/A	1 Line
4L7	4 Lines of 7 Dot Matrix	N/A	N/A	4 Line

**NOTE:** Do not set the pixel size greater than the largest font used in the message. It would slow down print speed and degrade print quality.

**NOTE:** Using Pixel 2L7, 3L7 or 4L7 will provide optimum speed and quality for dedicated 2-line, 3-line or 4-line character printing.

4. Height – Voltage controlling the overall height of the printed message. The maximum is 255, the minimum setting is 50 but can be different depending on the pixel size of the message and printhead alignment.

**Example:**



**NOTE:** The setting goes up to 255; however, if set to the maximum or close to the maximum, it can 'clip' the HV plates and either cut off the top of the print or cause a HV Trip.

**NOTE:** The setting goes down to 50; however, if set to the minimum or close to the minimum, it can 'clip' the gutter and result in bad prints.

5. Delay - Sets delay in raster's/stroke's between the print signal and the start of printing. This setting can be set from 0 – 999999999.

**Example:**

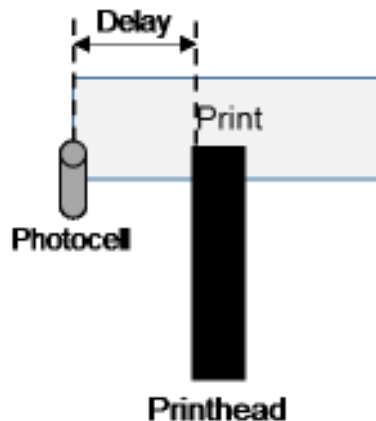

6. Width - Sets the print resolution (spacing between printed raster's/stroke's) by dividing the encoder input pulses, or the internal raster clock settings. This setting can be set from 0 – 9999.

**NOTE:** the higher the Width setting will affect the overall print speed.

**Example:**

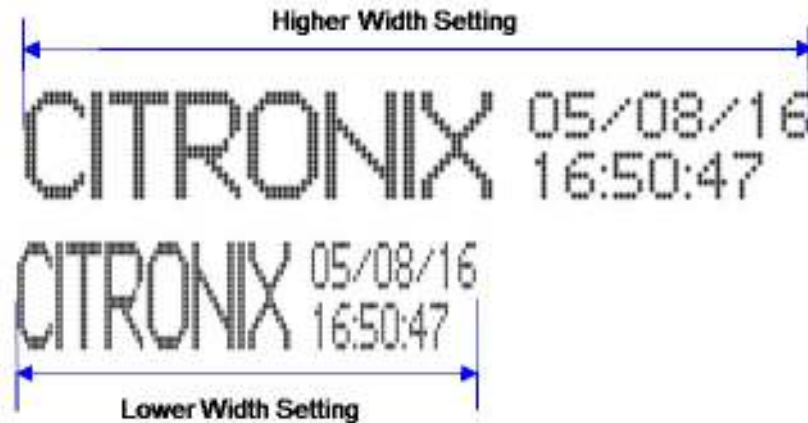

- Orientation - Sets direction and orientation of print. There are a possible 6 different orientations available. These are: Upside Up, Upside Down, Mirror Up, Mirror Down. When the Tower Print Option is Enabled: Tower CCW, Tower CW.

**Example:**

<b>Upside up</b>	ABCDEFGH TUVWXYZ
<b>Upside down</b>	ⱥⱦⱧⱨⱩⱪ ϷϸϹϺ
<b>Mirror up</b>	GFEDCBA ΣΥΧΨΥΤ
<b>Mirror Down</b>	ZYXWVUT ABCDEFH



- Bold – This setting duplicates raster's/stroke's increasing the width of characters. This setting can be set from 0 – 9

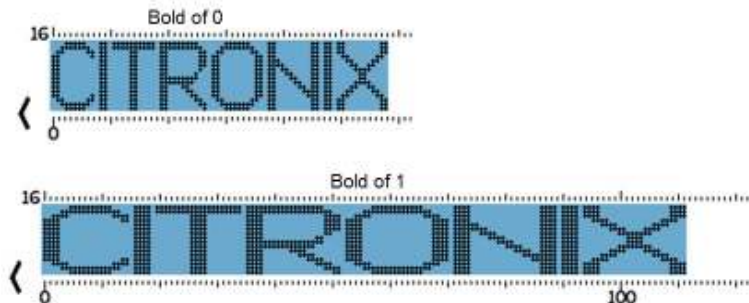

**NOTE:** the higher the Bold setting will affect the overall print speed.

9. Gap – This setting sets the inter-character spacing in raster's/stroke's. This setting can be set from 0 – 9

**Example:**

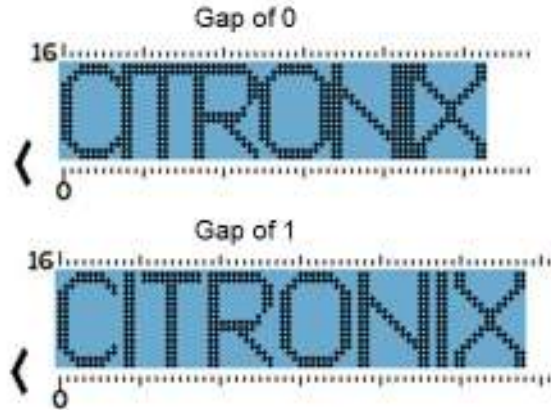

**NOTE:** the higher the Gap setting will affect the overall print speed.

10. Default Font Setting – This setting sets the font size all new message fields will default to. These options are: 5 / 7 / 9 / 12 / 16 / 19 / 25 / 31.

**Example:**

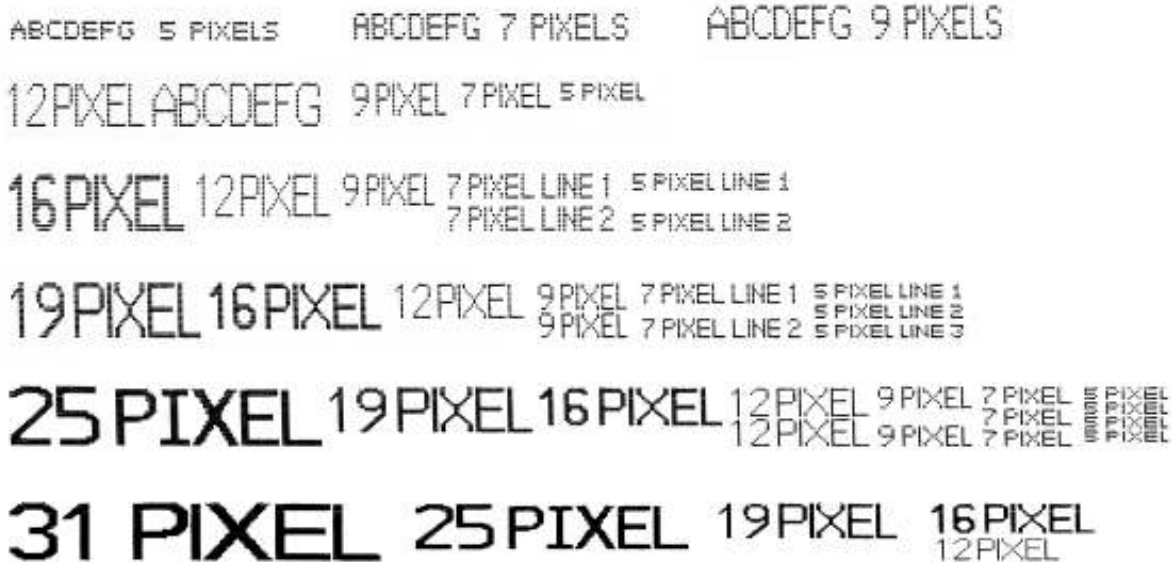

11. Repeat Print – This setting sets the number of times a message will be printed after each product detection signal. This setting can be set from 0 – 99999999.
12. Repeat Pitch – This setting sets the pitch between repeated prints in raster's/stroke's. This setting can be set from 0 – 999999999
13. AutoPrint Pitch – This setting allows a secondary delay when using AutoPrint feature. This delay is between each print cycle and is from beginning of a message to the beginning of the next. This setting has a limit of 2147483647.
14. Product Length – This setting is the length of the product being printed on. This is used for speed calculations on the Status screens. This setting can be set from 0 – 9999.

15. Encoder Print Length – Only used with Internal Encoder and used as a replacement for width setting. This setting can be set from 0 – 9999.
16. Alternate 0 – This setting turns on the European 0 with slash.
17. Tower Print – this setting enables or disables the 2 tower print formats. (examples below)

Tower Print Clockwise      ⌠ ⌡ ⌢ ⌣ ⌤ ⌥ ⌦ ⌧ ⌨ 〈 〉 ⌫ ⌬ ⌭ ⌮ ⌯ ⌰ ⌱ ⌲ ⌳ ⌴ ⌵ ⌶ ⌷ ⌸ ⌹ ⌺ ⌻ ⌼ ⌽ ⌾ ⌿ Ⓚ Ⓛ Ⓜ Ⓝ Ⓞ Ⓟ Ⓠ Ⓡ Ⓢ Ⓣ Ⓤ Ⓥ Ⓦ Ⓧ Ⓨ Ⓩ ⓐ ⓑ ⓓ ⓔ ⓕ ⓖ ⓗ ⓘ ⓙ ⓚ ⓛ ⓜ ⓝ ⓞ ⓟ ⓠ ⓡ ⓢ ⓣ ⓤ ⓥ ⓦ ⓧ ⓨ ⓩ ⓪ ⓫ ⓬ ⓭ ⓮ ⓯ ⓰ ⓱ ⓲ ⓳ ⓴ ⓵ ⓶ ⓷ ⓸ ⓹ ⓺ ⓻ ⓼ ⓽ ⓾ ⓿

Tower Print Counter Clockwise      Ⓚ Ⓛ Ⓜ Ⓝ Ⓞ Ⓟ Ⓠ Ⓡ Ⓢ Ⓣ Ⓤ Ⓥ Ⓦ Ⓧ Ⓨ Ⓩ ⓐ ⓑ ⓓ ⓔ ⓕ ⓖ ⓗ ⓘ ⓙ ⓚ ⓛ ⓜ ⓝ ⓞ ⓟ ⓠ ⓡ ⓢ ⓣ ⓤ ⓥ ⓦ ⓧ ⓨ ⓩ ⓪ ⓫ ⓬ ⓭ ⓮ ⓯ ⓰ ⓱ ⓲ ⓳ ⓴ ⓵ ⓶ ⓷ ⓸ ⓹ ⓺ ⓻ ⓼ ⓽ ⓾ ⓿

18. Alternate 1 – This setting turns on the European 1 with an underline.
19. Max Counters – This setting sets the number of counters saved/and used in a message. There are 1-5 counters available.
20. Alternate 7 – This setting turns on the European 7 with the dash.
21. Shifts – This setting sets the number of Shifts used in a message. There are a possible 24 shifts available, the default is 3.

Using the Navigation bar, set all of the Shift, Expiration Clocks, and Counter defaults (if used)

When all of the default settings are adjusted, press the [Back]  button located on the Navigation Bar.

Select the [Add Message]  option.

Using the keyboard, type in the name for the message, then press Save.



After creating the Message Name, the field selection screen will automatically open (as shown below). Select the type of field you want (Text, Autocode, Barcode, or Graphic) to use and press [Save]. Text and barcode fields can consist of fixed or variable data.

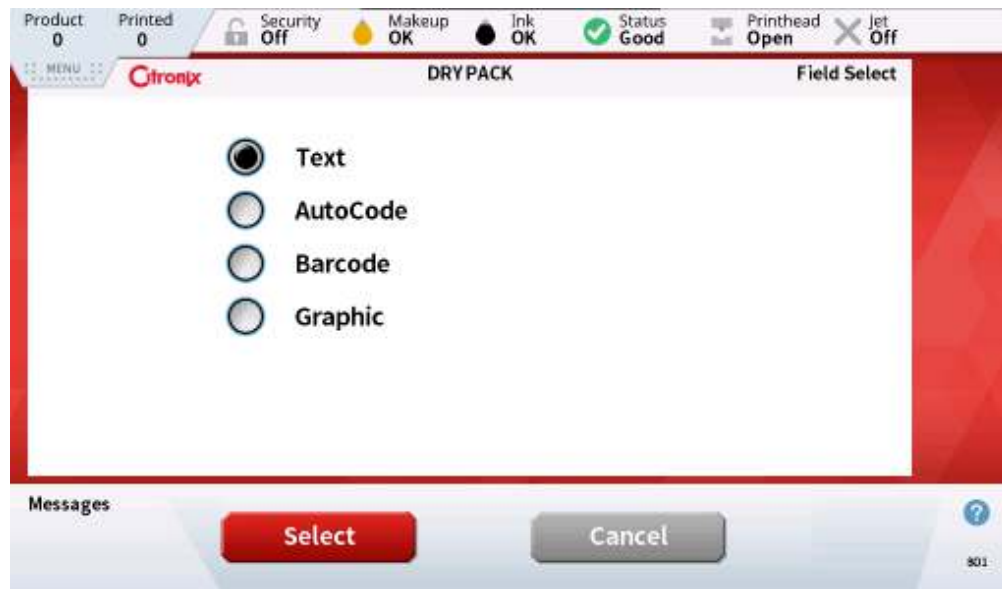

Enter the content of that field using the keyboard and then press Save.



The Field will be place in the Message.

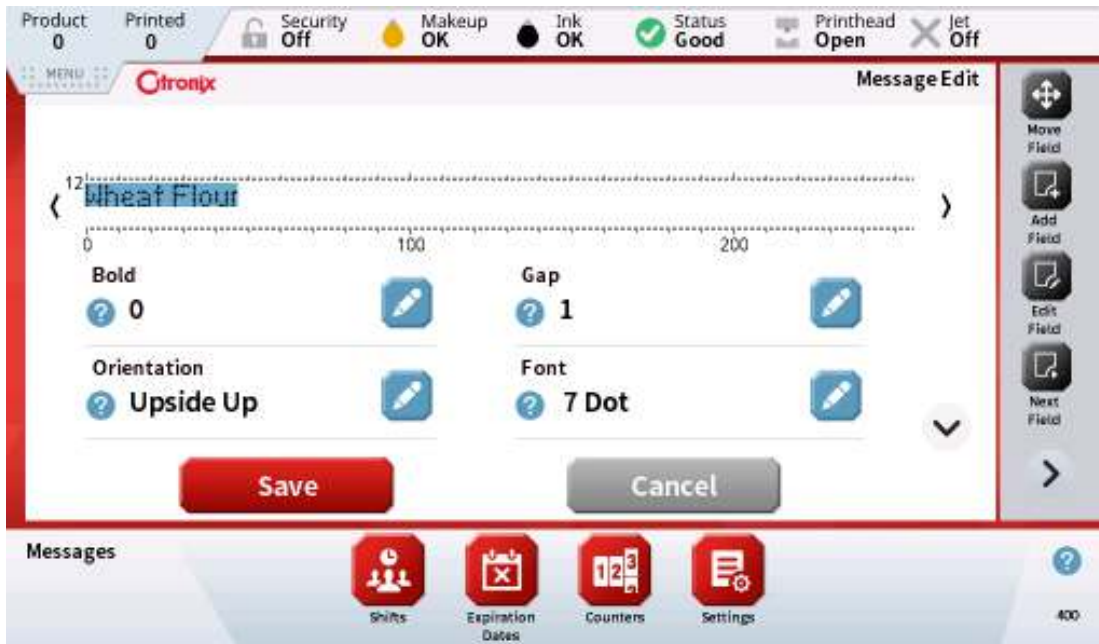

Next select the font size for this field by pressing the [Edit] button (as shown below).



Select the Font size from the list and press [Save] button.

***NOTE:*** Only the available fonts will be displayed to fit the message pixel size. There could be more than 1 screen of fonts. View the additional screens by pressing the arrow button (circled below).





Font Chart:

The following fonts are available for selection:

Font	Description	Ci5200	Ci5300	Ci5500/ci5650
5 Dot	5 Dot Matrix	1 or 2 Line	1 to 4 Line	1 to 5 Line
7 Dot	7 Dot Matrix	1 or 2 Line	1 to 3 Line	1 to 4 Line
9 Dot	9 Dot Matrix	1 Line	1 to 3 Line	1 to 3 Line
12 Dot	12 Dot Matrix	1 Line	1 or 2 Line	1 or 2 Line
16 Dot	16 Dot Matrix	1 Line	1	1 Line
19 Dot	19 Dot Matrix	N/A	1	1 Line
25 Dot	25 Dot Matrix	N/A	1	1 Line
31 Dot	31 Dot Matrix	N/A	N/	1 Line

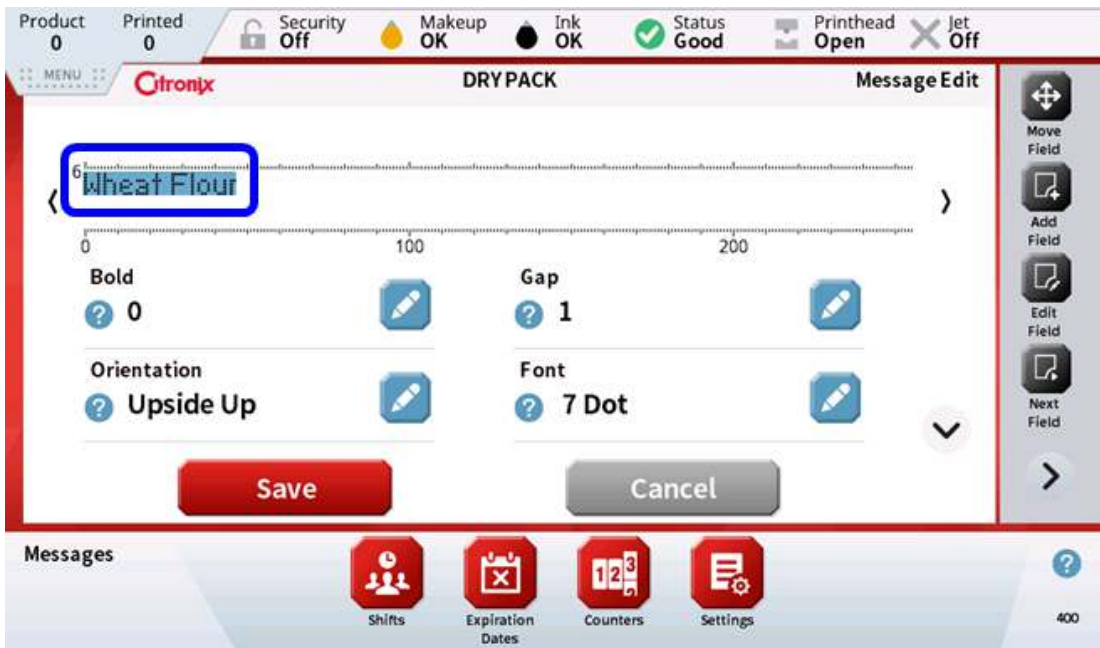
The new Font will be displayed in the WIZYWIG window.



To move the field, press the [Move Field]  button and use the arrows to move the field. Each field can be moved by pixel (1, 10, or 100 pixel) or by checking the [Snap to Grid] option, the field will move (up or down) to the next grid (red lines shown below) depending on the arrow selected (up or down). Pressing and holding a field that needs to be moved will cause the Highlight to become a darker blue color, this will allow the user to "drag & drop" the field in the location you want it to be. Then you can use the arrows to finely adjust the exact position. When done, press the [Move Field]  button again to go back.

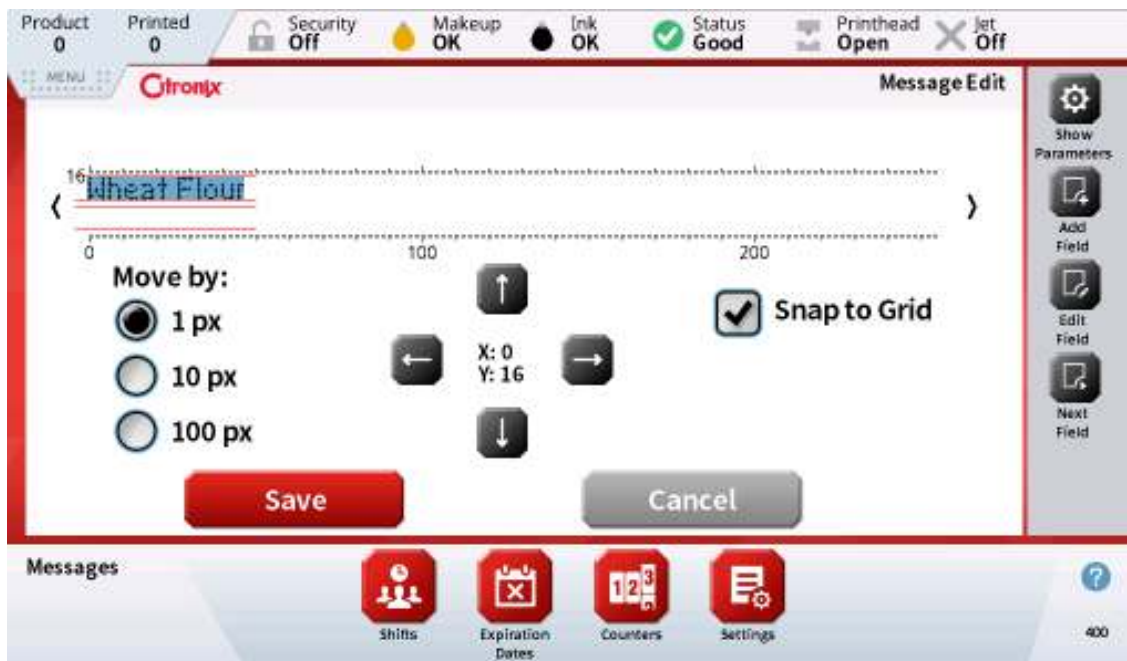

If additional fields are needed, press the [Add Field]  button to add a new field and follow the previous 3 steps.

When the message is complete, press the [Save]  button to save, rename or confirm the name, and then exit the Message Edit screen.

The new message will now be displayed in the Message List.



To select any message to print, just touch and highlight the message and press [Start Print]  button in the Function Tool Bar (as seen above).

## Message Fields

### Text Fields

Text fields are non-updating characters. Primarily inputted using the on board keyboard.



## Autocode

Autocodes allow Date, Time, Shift, Counter, User and Printer ID data to be inserted into a message field. These fields automatically update depending upon the selection. Some of these Autocodes can be adjusted forward example: in the case of a date/time to display and print an expiration date. (See below for more details)

AutoCode	AutoCode Basis
Time	Based on real time setup in System Properties
Date	Based on real date setup in System Properties
Expiration Date	Based on real date and expiration date setup in System Properties and Application Properties
Rollover Date	Based on real date and rollover time setup in System Properties and Application Properties
Expiration Rollover Date	Based on real date, rollover time and expiration date setup in System Properties and Application Properties
Shift	Based on real time and shift time setup in System Properties and Application Properties
Counter	Based on counter setup in Application Properties

**NOTE:** Rollover time is an offset of the 12 a.m. calendar day change. If rollover is set to 2 A.M., the calendar day will advance at 2 a.m., not 12 a.m.



Date: below are the different date options available for selection.



Note: changing the Delimiter is done using the “Field Date Delimiter” property in screen 2. (See below) It is important that the date field is highlighted for the delimiter property to be available.



Time: below are the different date options available for selection.

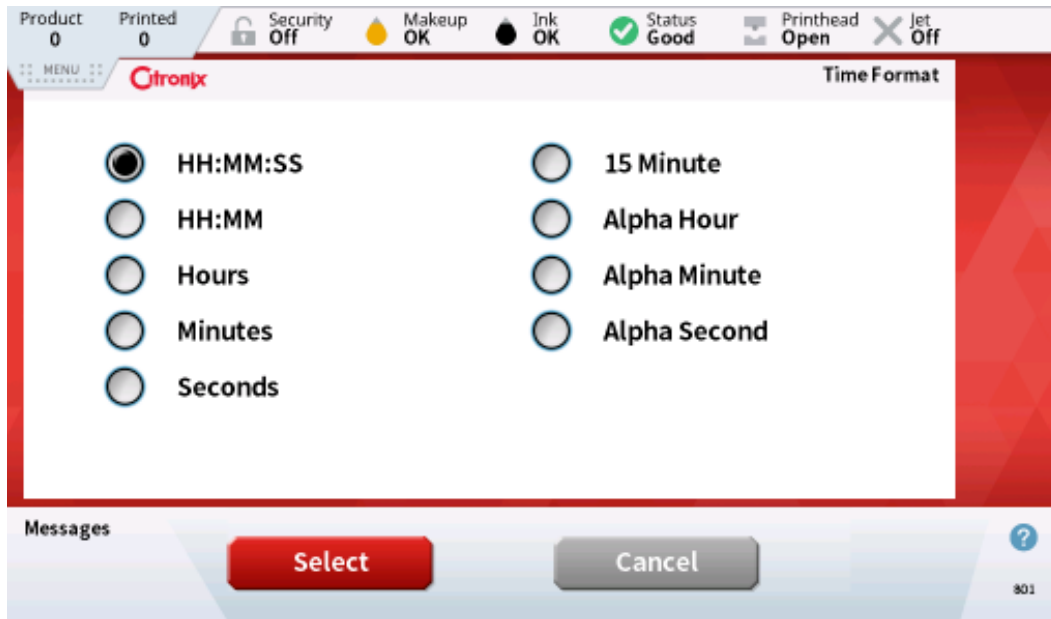

Note: changing the Delimiter is done using the “Field Date Delimiter” property in screen 2. (See below) It is important that the date field is highlighted for the delimiter property to be available.



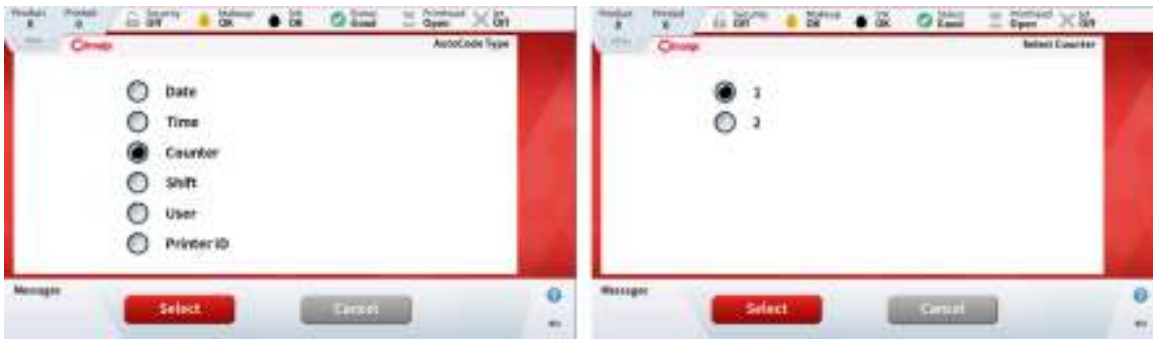

Counter: below shows how to insert a counter field into a message.

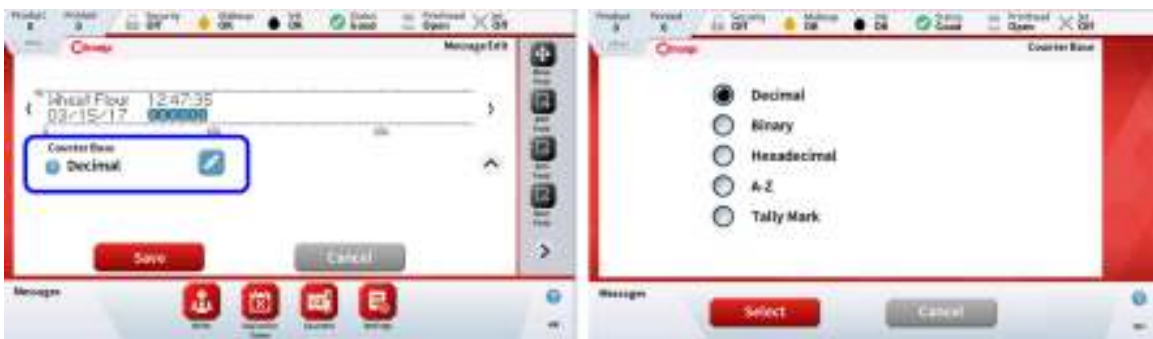

Note: to change the counter properties “Counter Base” use screen 2. (See below) It is important that the date field is highlighted for the delimiter property to be available.



There are up to 5 total counters that can be used in each message. These are setup from the [Message Defaults]  button found in the Navigational Tool Bar before creating a message, or by using the [Setting]  button (also in the Navigational Tool Bar) while creating or editing a message.

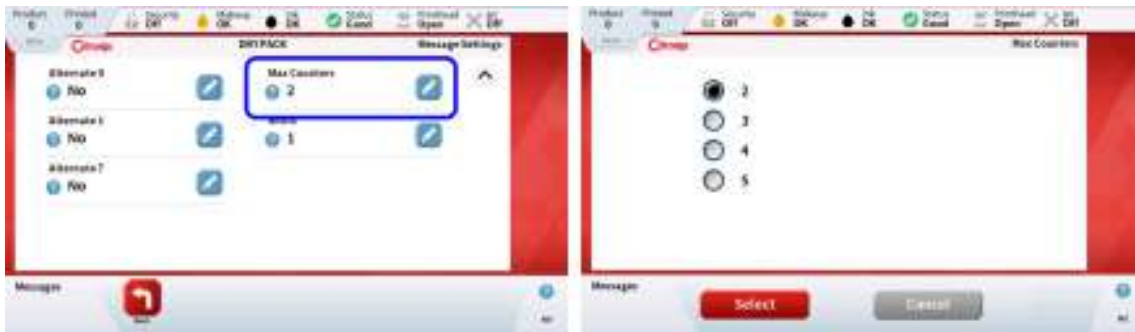



Once the number of counters being used has been selected, the following will show how to edit the counters.



Counter are now ready in a message

## User

User fields allow the printed message to show the User currently logged in the “Security” section. When this field is entered, any user logged onto the printer will be displayed and printed.

Then needing to insert or edit a “User” field in a message, press the [Add Field]  button in the Function Tool Bar located on the right of the message edit/creation screen. Select “Autocode” field type and press [Select] , then select “User” then press [Select] . Example below:







## Shift:

Then needing to insert or edit a “shift” code in a message, first set up the number of Shifts that are required. There are 24 available Shifts that can be programmed and used in each message.

To set the Shifts, press the [Settings]  button in the Navigational Tool Bar. Using the Down arrow button in the bottom right of the screen, drop to the 3<sup>rd</sup> screen.



Press the [Edit]  button and using the numbers keypad enter the number of shifts that is required, then press [Save] , then press the [back]  button.

Next press the [Shifts]  button in the Navigation Tool Bar at the bottom of the Message Edit screen. Setup the shift name(s), letter(s), or number(s) needing to be printed and set the times that correspond to those shifts. When finished press the [Back]  button to save the settings. Example below:

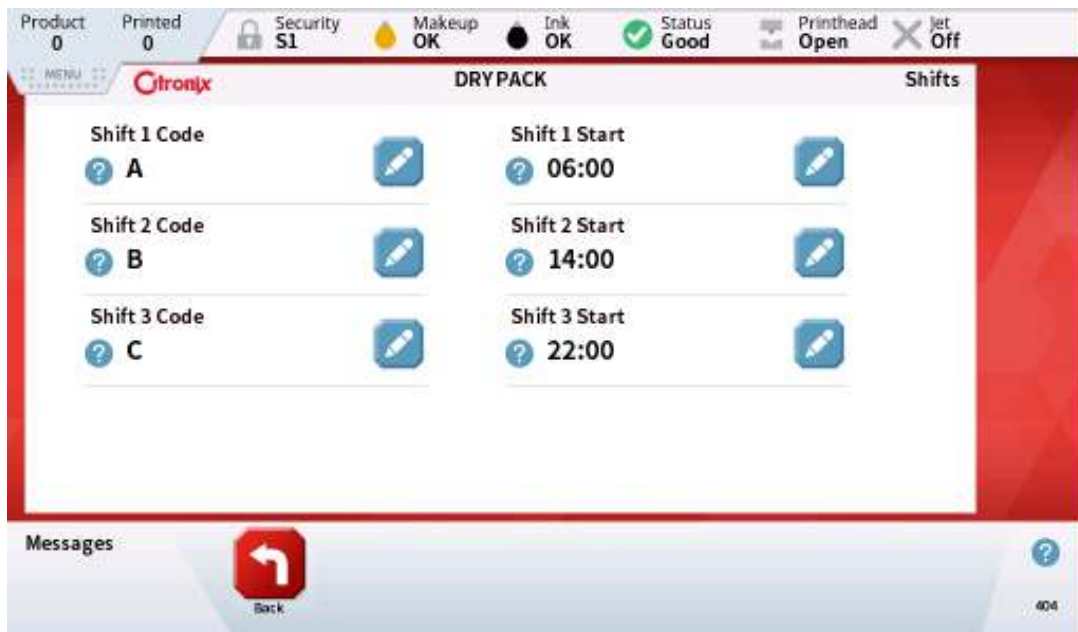

Next Add a field, select “Autocodes”, then select the “Shift” selection from the list and the field will be automatically inserted. Use the [Move] button to properly position the field in the message.





### Printer ID:



This Autocode allows a Printer identification name or number to be added to a message to be printed. The Printer ID can be alpha and/or numeric and up to 15 characters.



First setting the Printer ID is entered by from the Home screen, pressing the [Menu Bar Tab]



then press [Service]  Menu button. Press the down arrow button on the Service screen to view page 2 of the Service menu. Press the [Edit]  button and enter the name and/or number (15 characters max) of the Printer ID and then press [Save] . The Printer ID will be displayed.



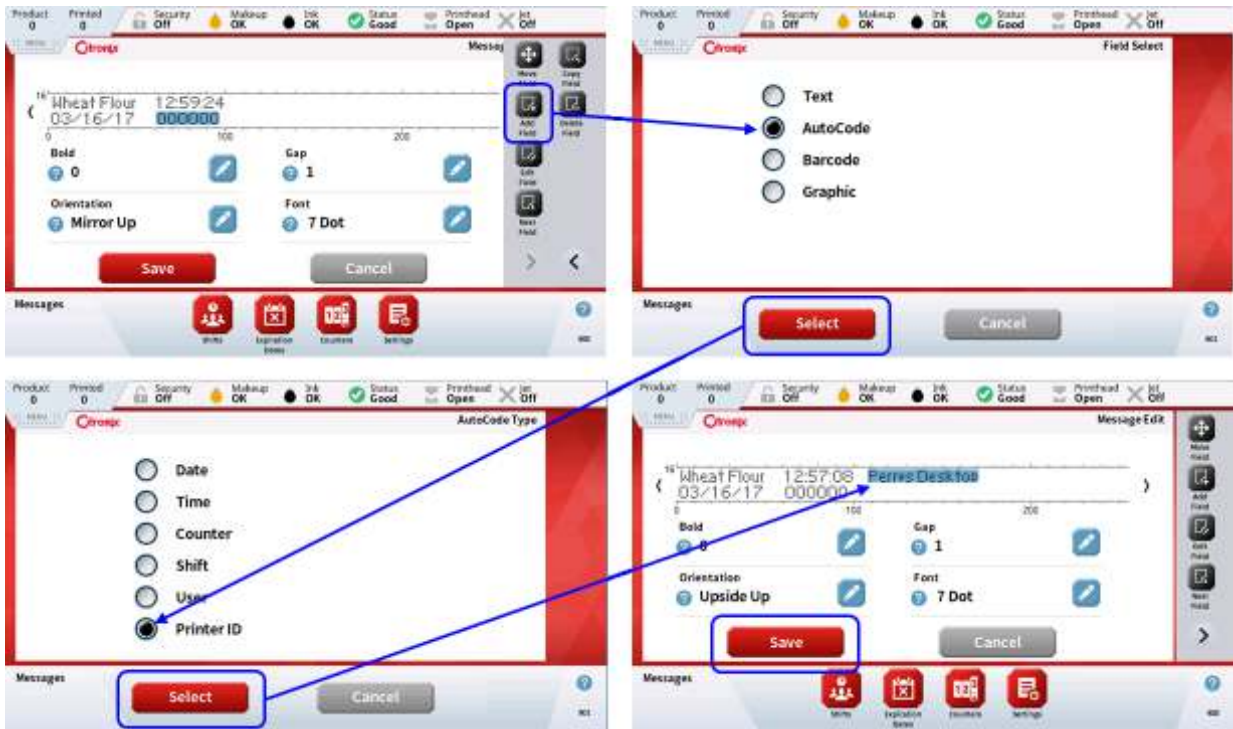

Next Create/Edit the message to use the Printer ID Field by creating /selecting the message and press the [Add Field] button, select "Autocode" and press the [Select]  button, select "Printer ID" and press the [Select]  button. The new field will be entered into the message and can be then

moved using the [Move Field]  button as described earlier in this section. Press the [Save]  button to save and exit the edit screen.



## Bar Code

To add a Barcode to a message:

Press the [Add Field]  button, select Barcode from the list then press [Select] .



Next select from the list (shown below), the barcode needed then press [Select] .



Using either the Number Keypad or the standard keyboard, enter the desired information (see chart below for available options), then press Save.

Description	Input (enter data)	Human Readable Text Available	Check Digit
Interleave 2 of 5	Up to 256 numeric characters or Counter	Yes	Automatic or Disabled
Code 39	Up to 256 alpha-numeric characters or Counter	Yes	Manual – must enter
Code 128	Up to 256 alpha-numeric characters or Counter	Yes	Manual – must enter
UPC A (11)	11 numeric characters	Yes	Automatic
UPC E (6)	6 numeric characters	No	Automatic
EAN13 (12)	12 numeric characters	Yes	Automatic
EAN8 (7)	7 numeric characters	Yes	Automatic
Datamatrix	Variable based on matrix	No	N/A



Next Select the Barcode size. Please note the max selection will always be the maximum pixel size of the message. See below.



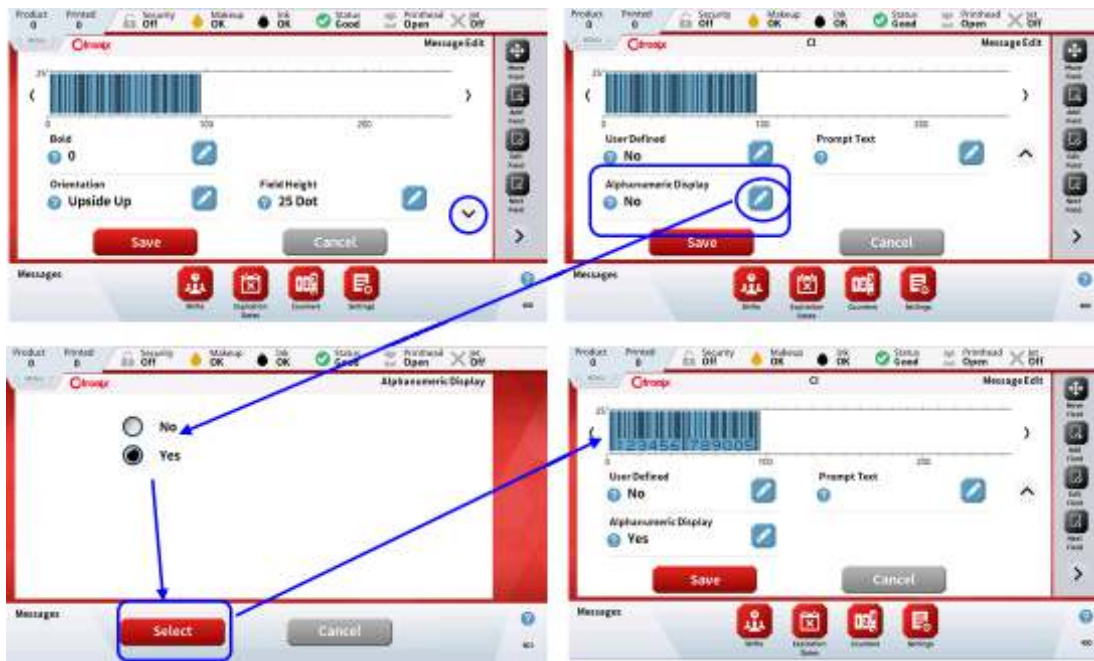

Note: adding Human Readable text below the barcode requires using the “Alphanumeric Display” shown on screen 2 to be changed to “Yes”. (See below)





## Graphic

Graphics/Bitmaps can be inserted into messages and printed. These need to be created in as a Monochrome Bitmaps. This can be easily done using Microsoft Paint. For more information on how to create graphics using Microsoft Paint see below.

Inserting a Graphic into a message:

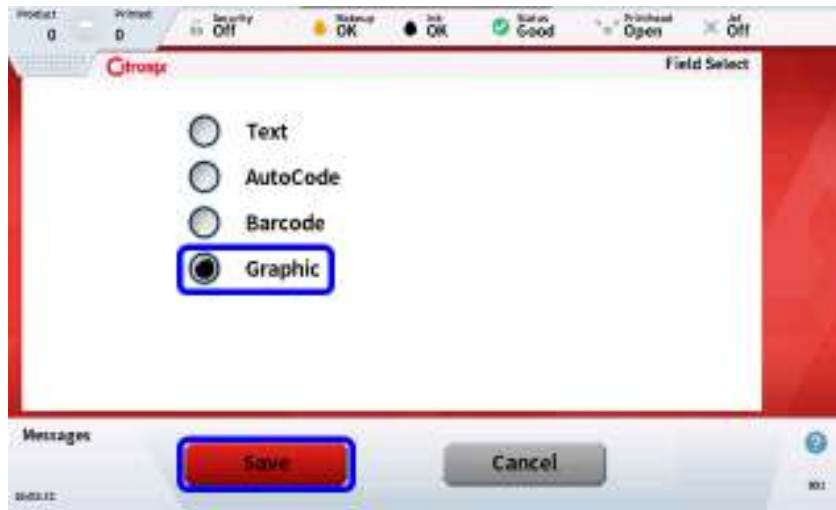
Press the [Add Field]  button and select Graphic from the options list and press the [Save]  button.



The Graphic List will appear. Touch/select the desired Graphic from the list and press the [Select]  button.

***Note:** Ensure the Message Pixel size will accommodate the graphic of the graphic could be cut off. If this needs to be changed, Press the [Settings] button in the Navigation Tool bar to change.*

The graphic will be inserted to the message. Use the [Move Field]  button to adjust the placement inside the message.

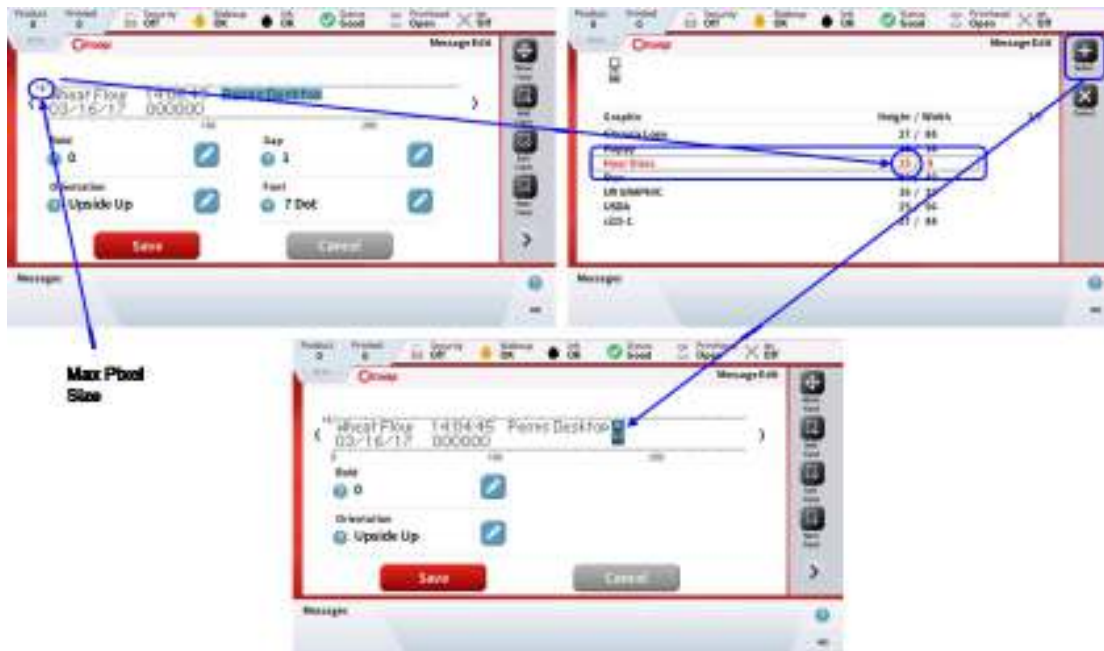

Continue to build or create the message. When done press the [Save]  button.

## How to Use Microsoft Paint to Create Printable Graphics

Microsoft Paint Utility can be used to create a monochrome bitmap image file that can be loaded on a CIJ Printer using the printer's built in "FileUpdate.htm" web page utility. This document provides a brief example of the steps involved.

### Invoke MS Paint

Click on the Window's "Start" button and at the "Search programs and files" entry box,

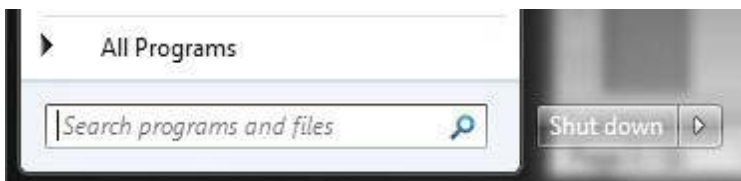

type in "Paint"

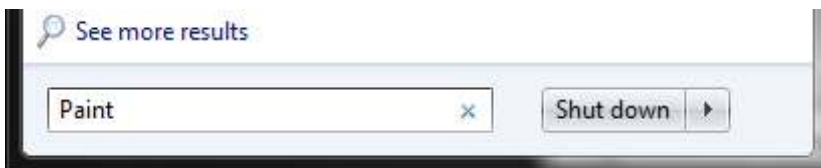

followed with the Carriage Return (Enter Key) or click on the "Paint" program.



Use "Paint" to create the Logo.

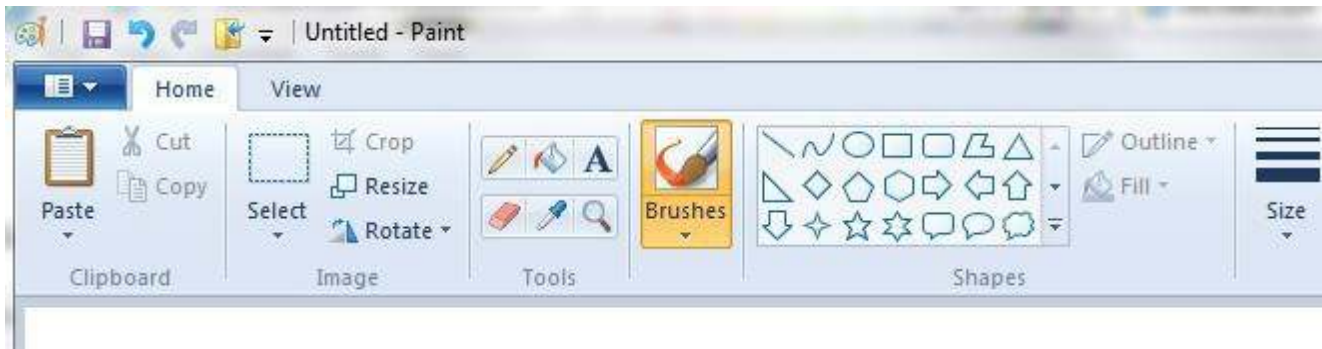

## Creating a Logo

A pixel is the smallest unit in a picture that can be addressed or controlled. Printable bitmap images can vary in height up to 31 pixels and a width that is evenly divisible by 8 (i.e. widths of 8, 16, 24, 32, 40,...). The bitmap image size is expressed as pixel Height x Width. In this example, the Paint program will be used to create a 31x48 bit pixel image of concentric rectangles.

Resize the work area to the Logo bitmap image size. Click on Image Resize.

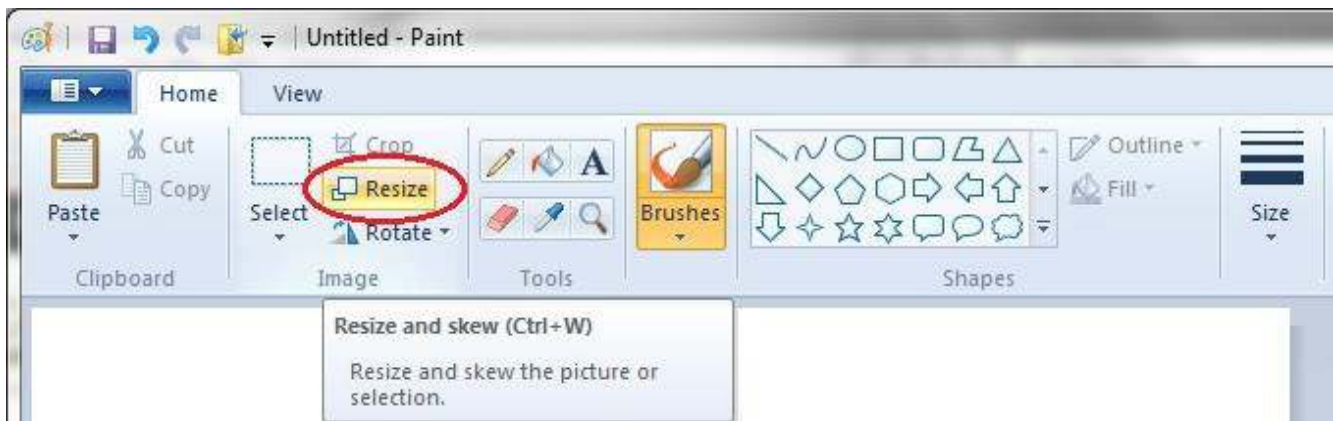

Set the graphic size. First, uncheck the "Maintain aspect ratio" box and select Pixels, set "Horizontal" to 48 and "Vertical" to 31 (before and after changes shown).

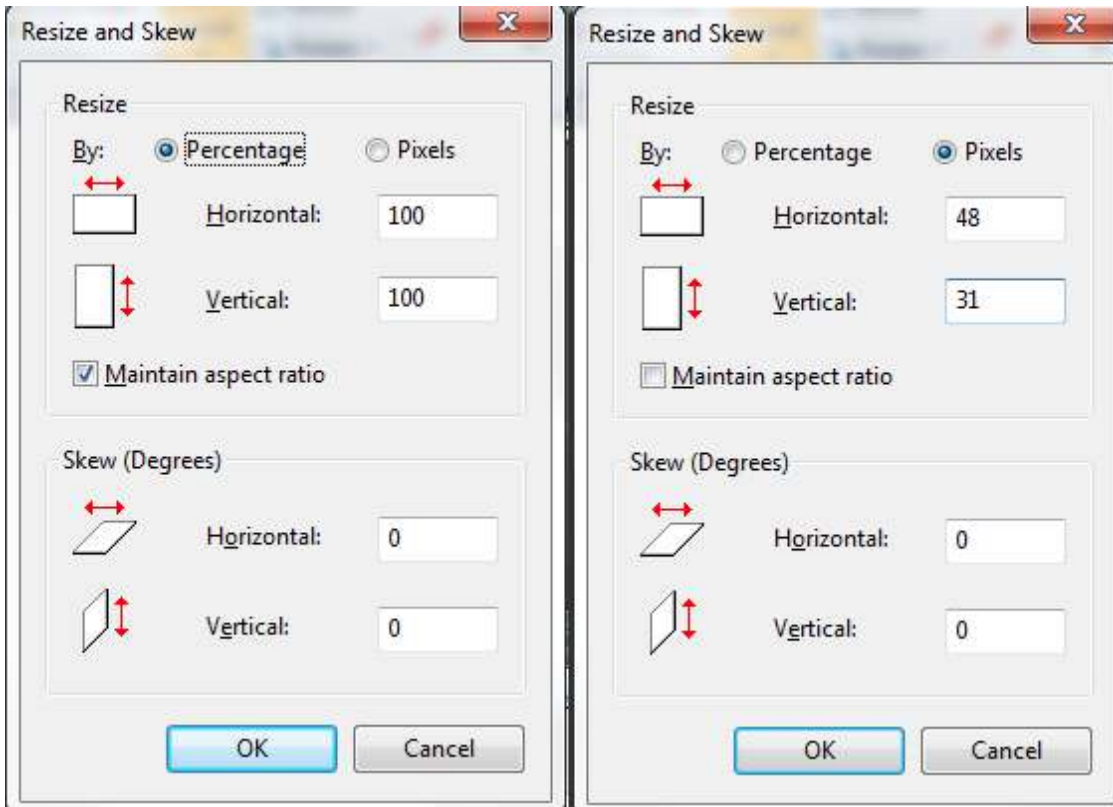

Click the “OK” Button and the work area will shrink.

Select the “View” tab and zoom in to increase the work area.

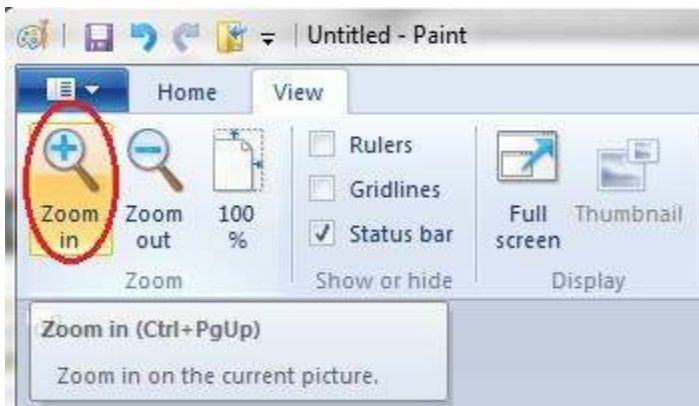

After zooming in on the work area, return to the Home tab.

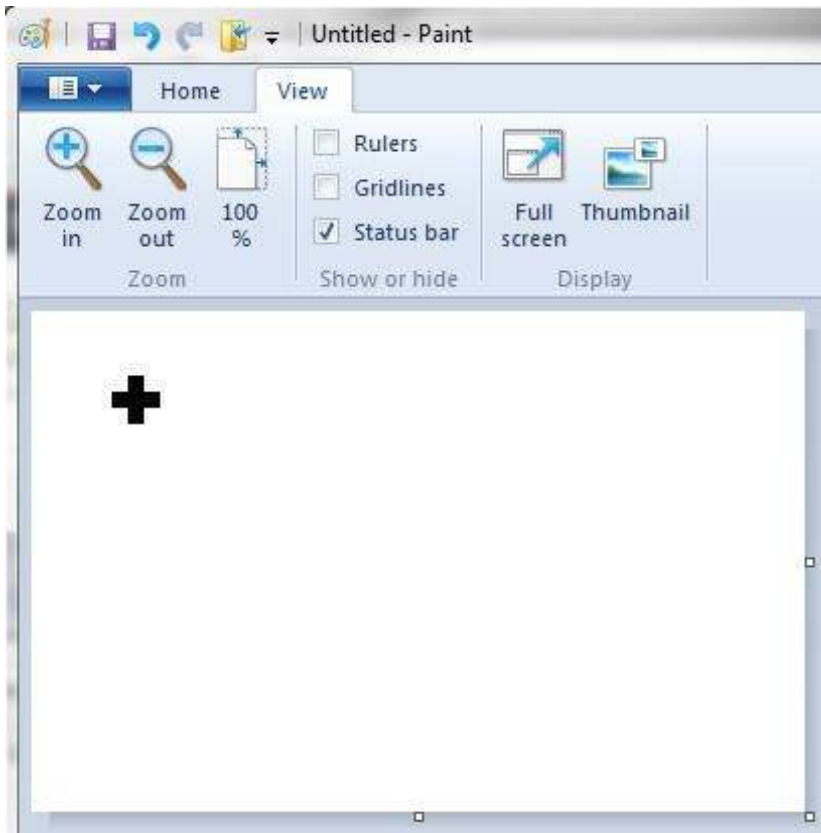

Since the printer is a monochrome, use only black and white as the image colors.

### ***Drawing the Image***

Select the Rectangle Shape using a mouse click.



(Optional) Select a "Size" for the lines and draw the Logo.

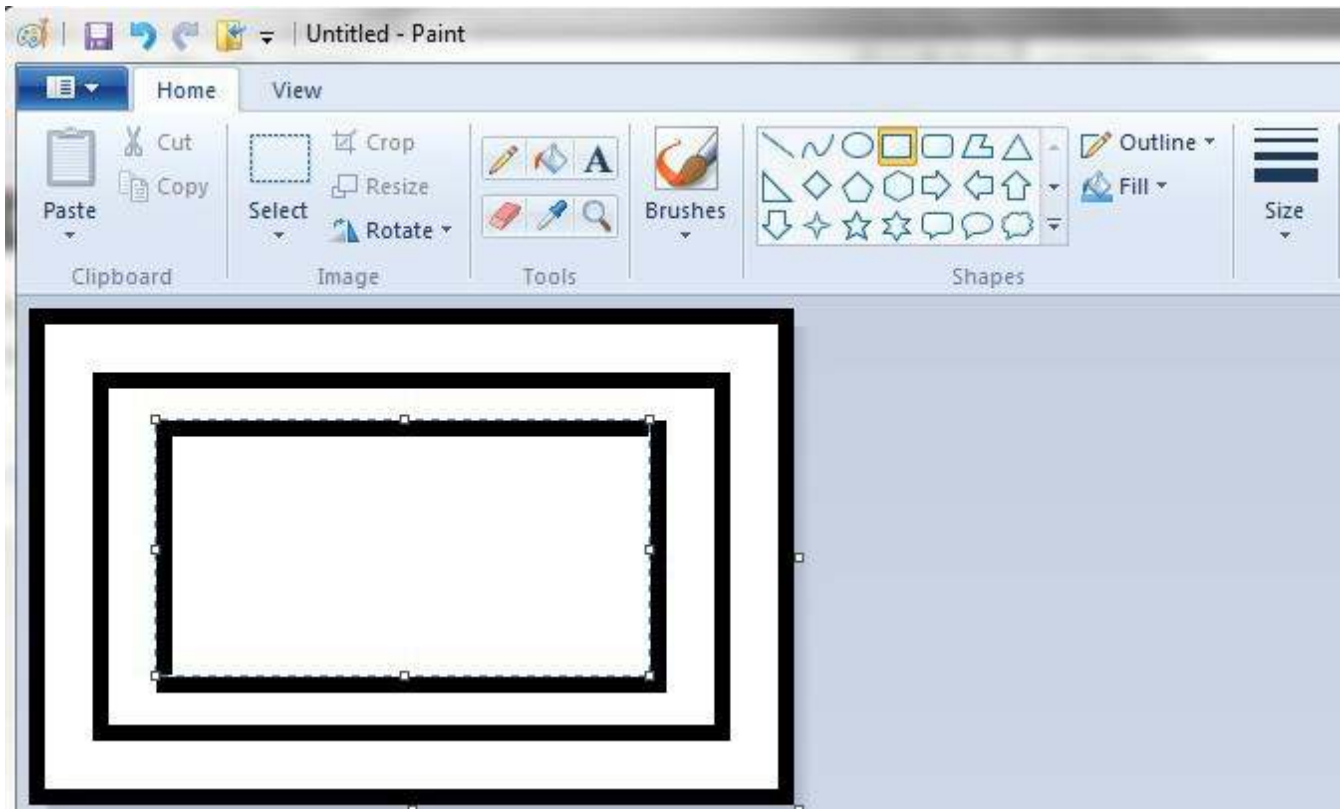

Draw a border long with other rectangles.

Save the Image. Click on save.

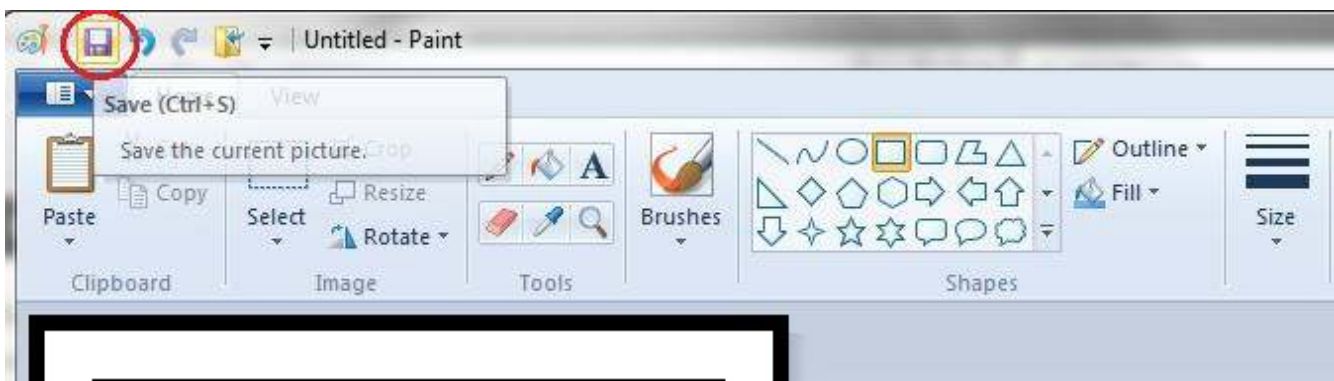

Save file "Rectangles31x48" as "Monochrome Bitmap (\*.bmp)."

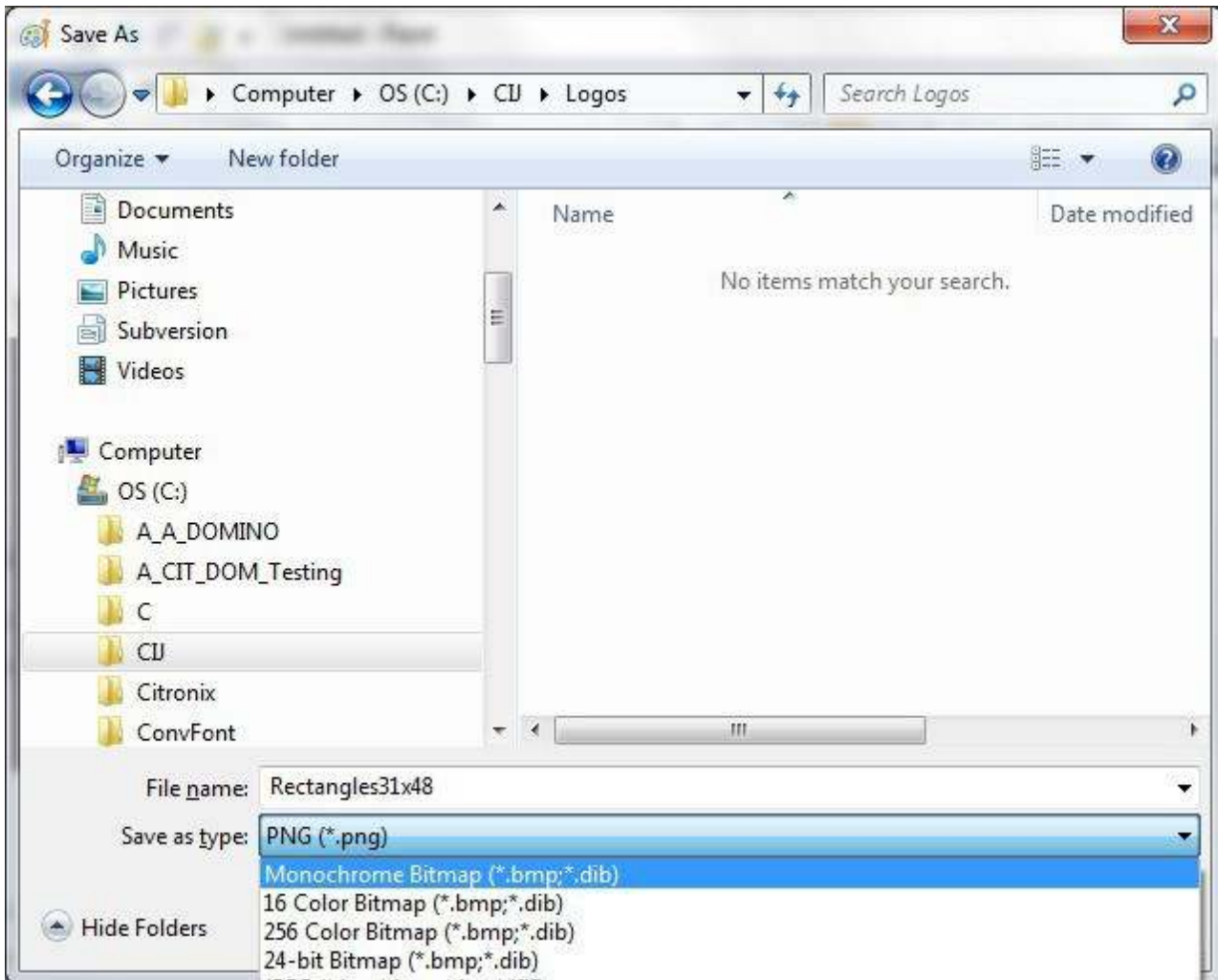

Do you want to continue? Yes! Click OK.

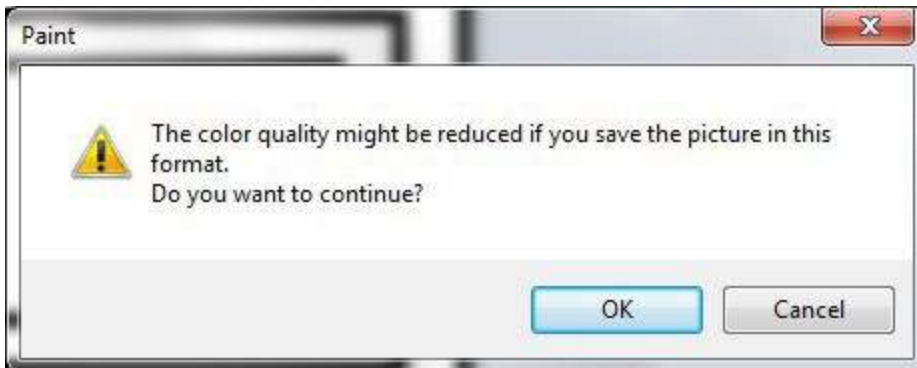

Bitmap File Saved.

For instructions on loading the graphic files onto the printer see section 6 Cleaning and Maintenance for “Uploading Graphics”.

## Message Options

### Graphic Utility

This utility is a list of Graphics/Logos that are currently stored and available use in a message field a message. From this menu graphics, can be copied or deleted by using the buttons available in the Function Tool Bar located on the right-hand side of the screen.











**NOTE:** For adding graphics to a printer, see section 6 "Uploading Graphics"

### Message Sequence

When operating in the Message Sequence mode, the Printer prints messages in order of a predetermined list for each print signal once this option is selected in Mode of Operation found in the Properties menu

To add/set a Message to the message sequence list:

5. Press the [Messages]  button in the Functional Tool Bar OR [Menu Bar]  Tab and select the [Messages]  button.
6. Select [Message Sequence] .
7. Press the [Add]  button. Do this for each message that needs to be added
8. Use the [Move up]  or [Move Down]  buttons to put the messages in correct order
9. Used the [Delete]  button to remove a message from the list

**NOTE:** The printer will print from top to bottom of the list

Example:

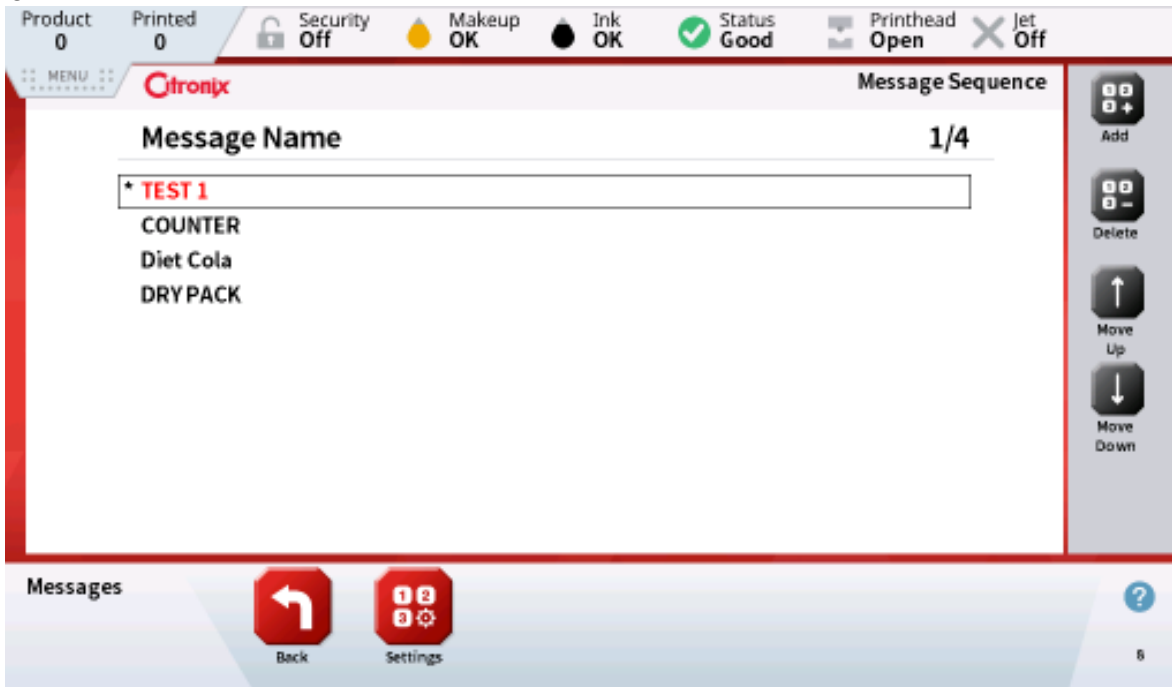

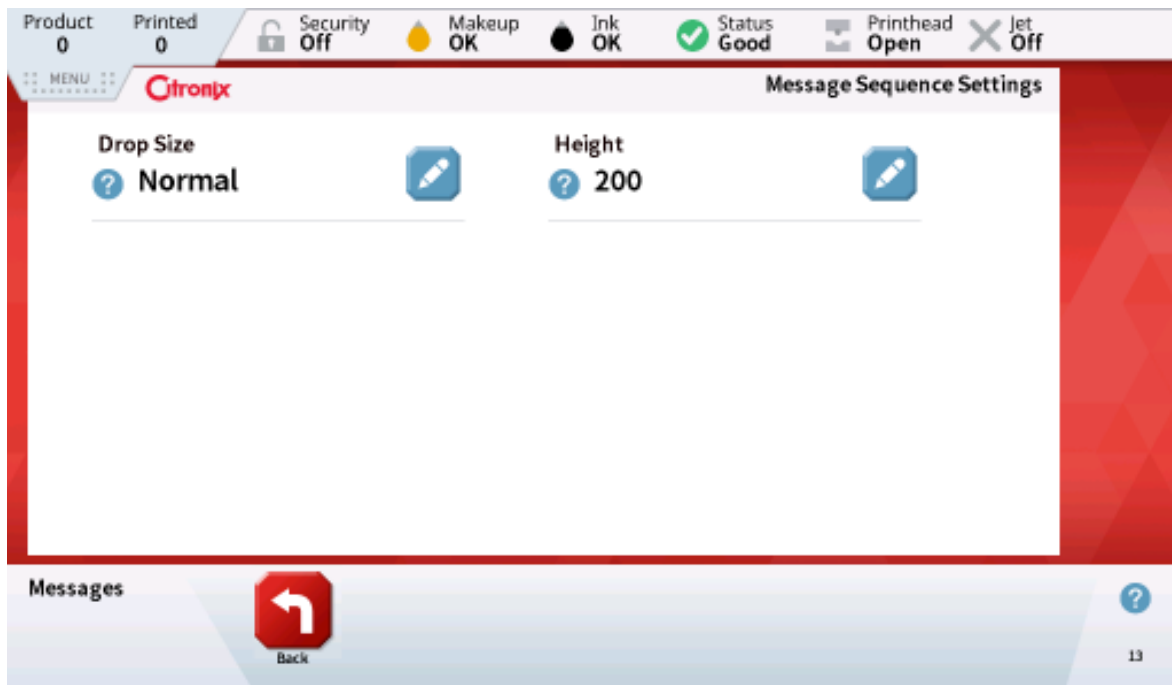

All messages in a message sequence must use the same drop size and height settings. To set the drop size and height setting that will be used for the message sequence, press the [Settings]  button in the Navigation Tool Bar circled above.



## Message Codes – External Message Select



When operating in the Message Code mode (enabled in Mode of Operation in the Properties screen), the Printer selects the Message to be printed by reading eight input lines. The eight lines make up eight bits of a binary number that can range from 0 to 255. All lines do not have to be used. One line can be used to select between two Messages.

After the Messages are created or edited, they can be added to the Msg Code list and assigned a number. This is done by:

1. Selecting the [Message Codes]  button in the Navigation Tool Bar at the bottom of the Message List screen.
2. Press [Add]  select the desired message from the message list and then press [Add] .
3. Using the number keypad enter the 3-digit number desired for that message, then press [Save]





1. To change or edit the number, press the [Edit]  button and use the Numbers Keypad to change, then press [Save] .
2. To delete a message from the list, press [Delete] . There will be a confirmation screen confirming the message is to be deleted.

***NOTE:*** *the message will only be deleted from the Message Code list, not from the Main message list.*

When the Photocell is triggered for a print, the eight input lines are read to determine which message is to be printed. If there is no Message with this Message Code value, the same Message used for the previous print is used.

The eight input lines go to connector J17 “SELECT.”

On this connector:

- Pin 1 is a 24-volt DC supply for possible external circuits
- Pin 2 is bit 0 - the least significant bit

- Pin 3 is bit 1
- Pin 4 is bit 2
- Pin 5 is bit 3
- Pin 6 is bit 4
- Pin 7 is bit 5
- Pin 8 is bit 6
- Pin 9 is bit 7 - the most significant bit
- Pin 10 is ground

The eight input lines are normally high and read as a “1” bit. The external connection must ground the pins to change them to a “0.”

If nothing is connected, the value is read as 255.

If only 1 line (Pin 2, bit 0) is to be used –

- and the other 7 lines are unconnected, the input value will be read as 255.
- and the other 7 lines are grounded, the input value is read as either 0.

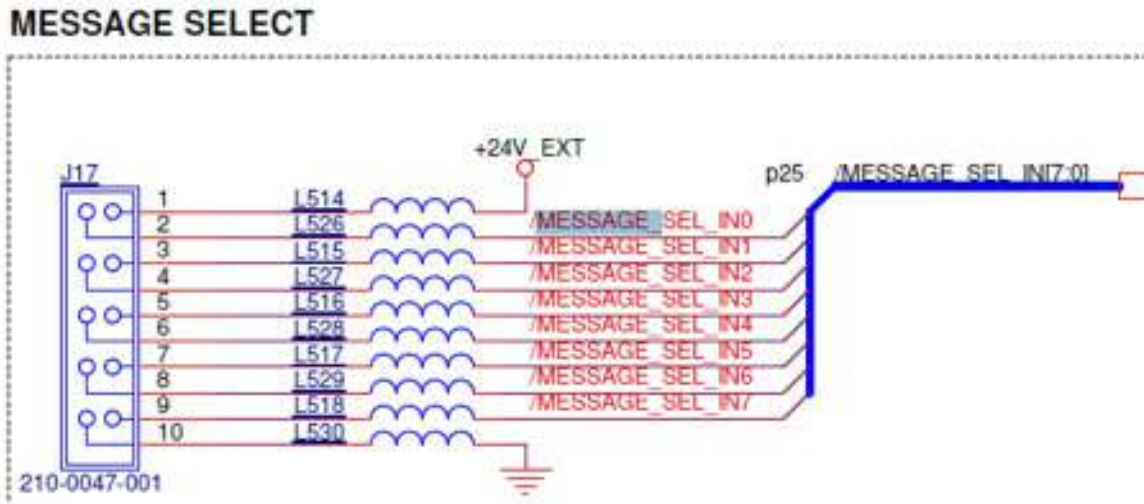

## Date Properties

Setup screen date properties such as Week start date, Hijri date and Atlas code. Also used to set up encoded dates and times and to select date and time delimiters (separators).



Settings	Action	Options
Week Start	Specify the starting point for the week of year autocode.	1-Jan Sunday Monday Saturday ISO – <a href="#">see definition below.</a>
Hijri Date Adjust (days)	Allows a day offset for the Hijri calendar.	0, 1, 2.
Atlas Code Enable	Enables the Atlas code option.	Enabled, Disabled.
Atlas Start Date	Defines the beginning day of year.	Day, Month, Year.
Encoded Date YMD	Allows entry of an encoded date.	Year, Month, Day.
Encoded Time HMS	Allows entry of an encoded time.	Hours, Minutes, Seconds.

### ISO definition:

The ISO definition of the week number is an international standard that many companies use. According to the ISO definition, the week must start on Monday.

Also, the ISO definition for Week 1 may also be stated in different ways:

- The week with the year's first Thursday in it.
- The week with Jan. 4 in it.
- The first week with four or more days of the new year in it.
- If Jan. 1 is a Monday, Tuesday, Wednesday, or Thursday, then it is the first week of the year.

If a normal year starts on Thursday, or a leap year on Wednesday, then that year will have 53 weeks.

## Calendar Properties

The Calendar Properties screens allow users to define names for Day of Week, Day of Month, Month, and Year. Use the [Edit]  button open/edit the Calendar Properties screens. Names may be given any name up to 20 characters each. Use AutoCodes “Alpha” to enter into the Message: Alpha Day of Week, Alpha Day of Month, Alpha Month and Alpha Year. Alpha Day of Week replaces the numeric day of week with the text entered on the Day of Week screen, likewise with the rest of the Calendar Properties.

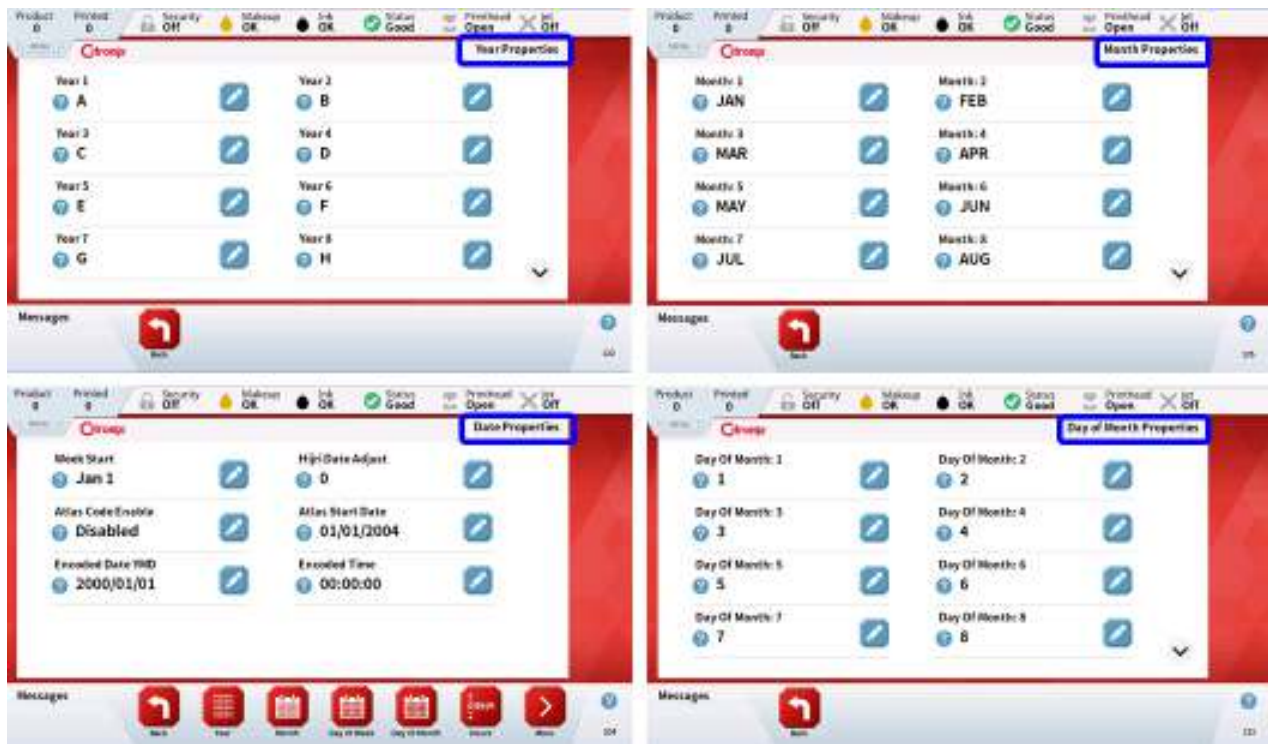

## Time Properties

The Time Properties screens allow users to define Alpha Characters for Hour, Minutes, and Seconds. Use the [Edit]  button to open the Time Properties screens. Up to 9 characters can be entered for each. Use Autocodes “Alpha” to enter into the Message: Alpha Hour, Alpha Minutes, Alpha Seconds. As with the Alpha Day of Week, the Alpha Time options replace the numeric Hour, Minute, and Seconds with the text entered in the screens (shown below).





## Message Defaults

See section above “Create Message” for details.



## Edit Message

(Similar to create message)

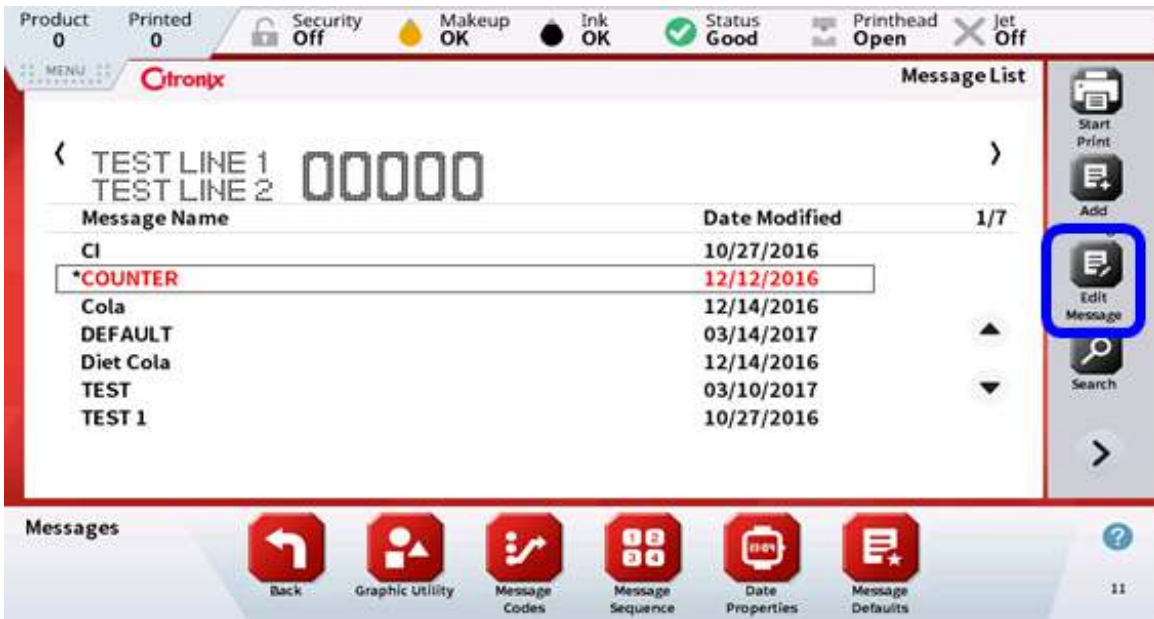
Press the [Messages]  Button in the Functional Tool Bar, OR [Menu]  Tab then press the [Messages]  button to bring up the Message List (shown below).



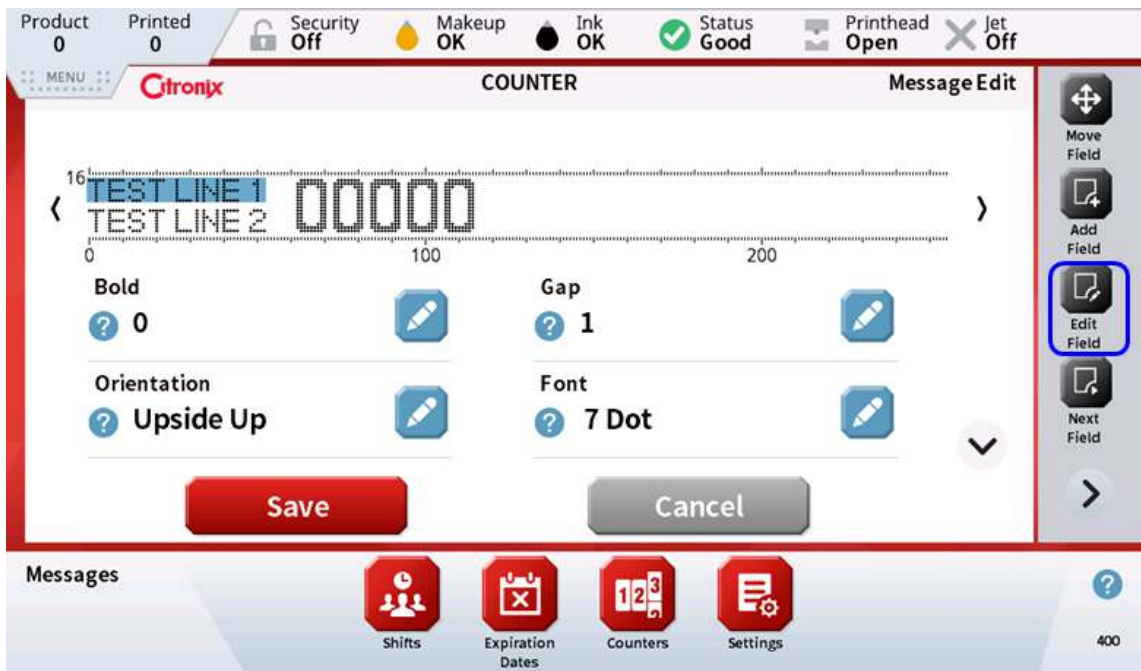

Touch (highlight) the message to be edited, then press the [Edit Message]  button.

Touch to highlight the field to edited, then press the [Edit Field]  button found in the Function Tool Bar. Use the Keyboard or Numbers keypad to edit the field and select [Save]  when complete.





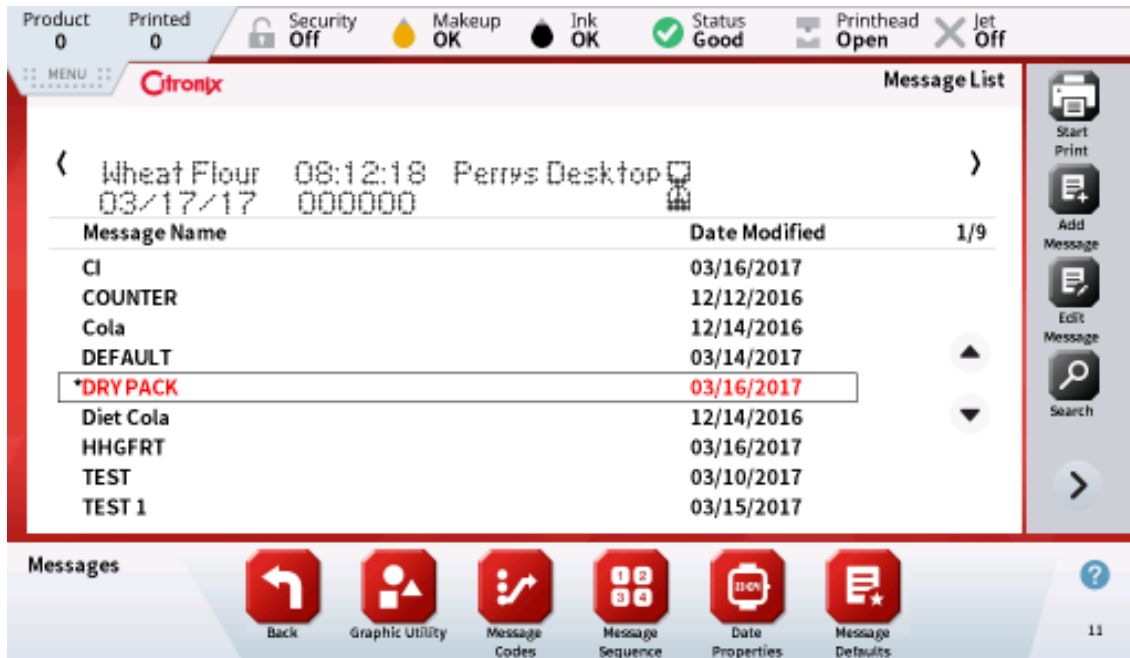

## Message Store and Search

(Similar to create message)

Press the [Messages]  button in the Home screen Navigational Tool Bar OR [Menu] Tab  then press [Messages]  button to bring up the Message List (shown below).



Search by pressing the [Search]  button in the Function Tool Bar (shown below) and using the keyboard, type the message name, then press the [Save]  button. All messages with the search criteria will be shown in the new Message List and can be printed by selecting the message (if more than 1) and pressing the [Start Print]  button or edited by pressing the [Edit]  button. Pressing the [Clear Search]  button will display the whole message list.

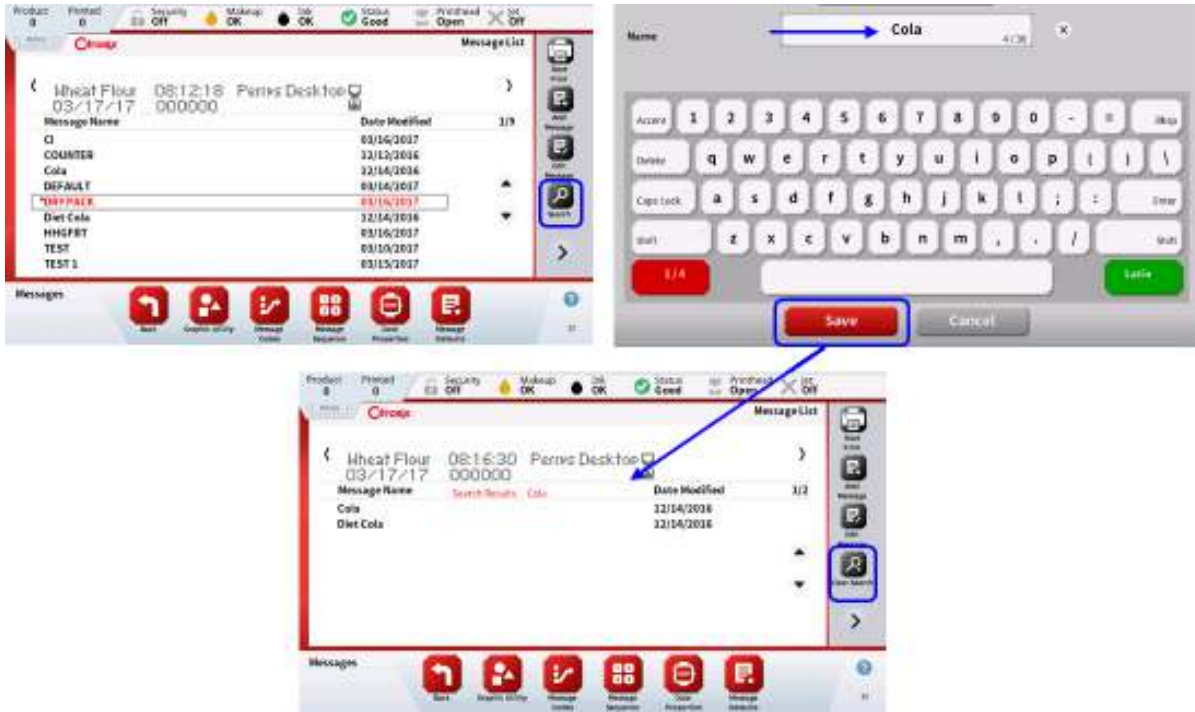

## Selecting a Message to Print

Navigate to the Message list by pressing the [Messages] button OR press the [Menu] tab and then selecting [Messages] .

Select/highlight the message in the Message List and press [Start Print] . The screen will return to the Home screen showing the message in the WYSIWYG window in the middle of the screen.



## Print Adjust Parameters

Print Adjust Parameters are printing functions that are message specific. When these settings are adjusted and saved will be retained each time that message is recalled to print. These can be different

for each message. This allows different messages to be used for different products or production lines at different drop sized (depending on the printer type), delays, Print Quality, etc.....

The Print Adjust Parameters are:

1. Drop Size
2. Print Quality
3. Delay
4. Width
5. Gap
6. Orientation
7. Bold
8. Height
9. Auto Print Pitch

From the Main screen, press the [Print Adjust]  button located in the Navigation Tool Bar.

The following 2 screen are available to be adjust “on the fly” or while the printer is printing on line.



## Drop Size

The drop size changes the size of the printed drop. This can make the print look darker or bolder; however the drop size can/will affect the speed that can be printed. The following is a chart of the Drop Sizes allowed by printer type.

Printer Type	Normal	Macro	Micro	HS50
ci5200	X	√	X	X
ci5300	√	√	X	X
ci5500	√	√	X	X
ci5500 Pigment ci5650 Pigment	√	√	X	X
ci5500 Heavy Pigment ci5650 Heavy Pigment	√	√	X	X
ci5650	√	√	X	X
ci5500 Micro ci5650 Micro	X	X	√	X
ci5500 HS50 ci5650 HS50	X	X	X	√



Select the Drop Size by pressing the [Edit]  button and select the drop size from the list.

**NOTE:** *only the allowed Drop Size will be displayed in the selection list.*

### Print Quality (ciPrecisionPlus)

The lower the Print Quality setting the faster the print speed and typically visually lower print quality. The higher the Print Quality setting the slower the print speed and typically better print quality.



The Print Quality settings enable you to increase the speed while keeping the print quality as high as possible. The selection will be a value between 0 (fastest speed/lowest print quality) and 300 (slowest speed/best print quality). The Print Quality will increment in steps of 20. To adjust the Print Quality, press

the [Edit]  button to the right side of the Print Quality number. Then select from the list while printing then press [Select] . Adjust to the best print quality.

**NOTE:** *Delay and Width would also need to be adjusted once Print Quality has been set.*

### Delay

Delay defines the amount of time (distance) between the photocell trigger and when the print starts.

Press the [Edit]  button to the right side of the Delay number. Using the numbers keypad, enter the delay setting (value between 0 and 999999999) then press [Save] .

Review the position on the package/product. If additional adjustments are needed, repeat the above edit process.



## Width

Width defines the amount of time/space between each vertical raster/stroke. An increase in width will increase the length of a message. Press the [Edit]  button to the right side of the Width number. Using the numbers keypad, enter the Width setting (value between 0 and 99999) then press [Save]





***NOTE:*** Width also effect print speed. Example: the higher the number the wider the message length and the faster the print speed.

## Gap

Gap defines the amount of time/space between printed characters. Press the [Edit]  button to the right side of the Gap number. Select the desired spacing from the list then press [Select] .

***NOTE:*** Gap also effect print speed. Example: the higher the number the slower the print speed.

## Orientation

Orientation is the positioning/direction in which the message is printed. To change the Orientation, press the [Edit]  button to the right side of the current orientation setting. Select from the list and press [Select] . There are four (4) Orientations: Upside Up, Upside Down, Mirror Up and Mirror Down. Below are examples.

1. Upside Up  
ABCDEF G  
TUVWXYZ

2. Upside Down  
TUVWXYZ  
ABCDEF G

3. Mirror Up  
ABCDEF G  
ZYXWVUT

ZYXWVYZ  
ABCDEFG

#### 4. Mirror Down



### Bold

Bold defines the number of times that every printed raster (vertical stroke) is repeated. Each bold increment increases the overall length of the print. To select a bold value, press the [Edit]  button to the right of the bold valve. Select the desired setting from the list (between 0 and 9) then press [Select]

Select



**NOTE:** *The higher the bold setting the slower the print speed. For example; a bold setting of 3 will print slower speed than a bold setting of 1 or 0.*

### Height

The Height setting defines the overall height of the message. To adjust the Height setting, press the [Edit]  button to the right of the Height valve. Adjust using the numbers keypad enter the desired setting (between 50 and 255) then press [Save] .

**NOTE:** *Setting the height too low can cause the print to clip the gutter block. This causes the printhead to also get dirty. Setting too high can also result in a dirty printhead and multiple HV Faults. An average setting of 200 works best.*

### AutoPrint Pitch

AutoPrint Pitch defines a fixed amount of time/space from the beginning of one message to the beginning of the next when in AutoPrint mode. To adjust the AutoPrint Pitch setting, press the [Edit]  button to the right of the AutoPrint Pitch valve. Adjust using the numbers keypad enter the desired setting (between 0 and 2147483647) then press [Save] .

### Repeat Printing



The current message can be repeated for a specified number of extra prints for one product detect signal.



**Note:** *The number of counted repeats is extra to the initial print.  
Example: 6 will print 7 times total.*

To setup Repeat Printing:

Create a new message or Edit an existing message as described in the above sections.

While in the Edit menu, press the [Settings]  button in the Navigation Tool Bar. Using the down arrow button, scroll down to screen 2.

Using the [Edit]  button, enter the number of Repeat Prints needed using the numbers keypad, then press [Save] . (Remember total number of prints will be +1 of the number entered).

Then Press the [Edit]  Button to set the Repeat Pitch using the numbers keypad enter the number for the spacing then press [Save] .

***NOTE:*** *The Repeat Pitch is the distance from beginning of one message to the beginning of the next. If the Repeat Pitch is too small, the printer will lose Phase and fault out. There must be a least 50 Raster space between prints.*



## Add Ink and Makeup

To ensure the quality and proper fluid type, each authorized Citronix ink and Make-up bottle will have an ciSafeFill label attached to the back. This is to provide extra protection to ensure proper operation of your Citronix printer.

If the Ink Low, Makeup Low warning message appears on the Display (shown below), the following steps need to be taken:

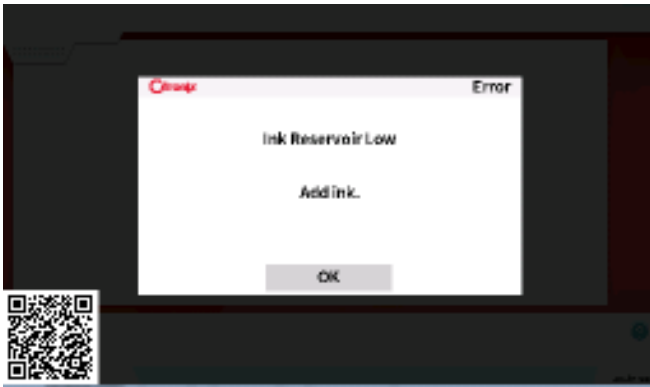

Press the [OK] button. The next screen will ask you to scan a new bottle. Do this by holding a bottle up to the ciSafeFill icon on the touch screen so the two (2) ciSafeFill  symbols match for approximately 2 seconds. The screen will read and verify the fluids and give you further instructions once the scan is complete.

Once the fluid is verified, remove/open the Ink (black) or Makeup (yellow) fill cap on top of the printer. Do NOT remove the foil seal.



Insert the Ink or Makeup bottle in the proper fill port and rotate clockwise by 90° to lock it in place.



Makeup bottle inserted in fill port



Ink bottle inserted in fill port



Makeup bottle rotated 90o clockwise    Ink bottle rotated 90o clockwise

Ensure that bottles are completely empty before removing to avoid spilling the fluid. Remove an empty bottle by rotating it counterclockwise by 90°, pulling the bottle out of the fill port then disposing of it according to local regulations.

Make sure to refit the Ink or Makeup fill cap once the bottle has been removed.

***NOTE:*** The Ink bottle, fill port and cap have a key of four (4) tabs. The Makeup bottle, fill port and cap have a key of three (3) tabs to avoid misplacement of bottles.

***NOTE:*** Do NOT use Cleaning Solvent in place of Makeup as Printer will not operate correctly.

***NOTE:*** Do NOT use Makeup in place of Cleaning Solvent or the Jet will not start correctly.

## **Status**

The Status screens provide more detailed information on each of the printer's subsystems. These screens are typically used during maintenance and repairs.

They consist of the following screens:

1. Status (main screen)  
Indicates status of the filters, printer temperatures, Phase, and Pressure
2. Event Log  
Allows viewable logs from errors, ink, message, misc., and all
3. Active Alarms  
Current Active Alarms listing
4. Viscosity Status  
Shows current viscosity status
5. Speed  
Speed status screen (performance)
6. Filters  
Status of filter hours and expiration  
Allows filter hour resetting
7. System Info  
Information that you will be require to have when requesting assistance in any diagnostics  
Displays Local Distributor contact information

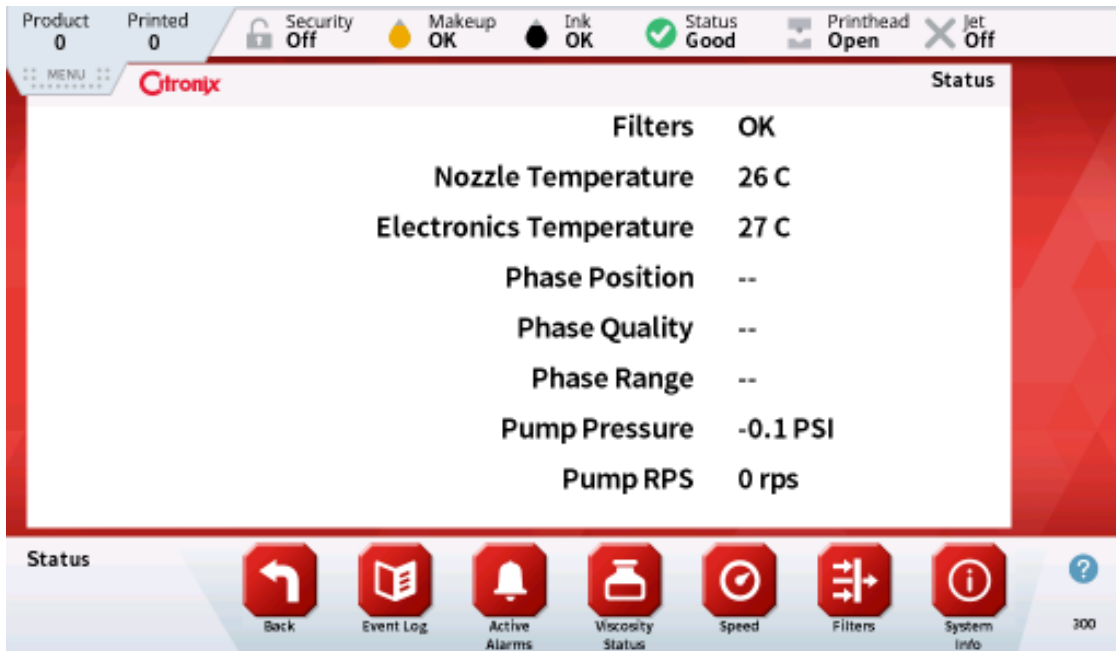

## Status (Main)

From this Main screen the details of the following can be monitored.

- Filters  
Indicates the status of the filters
- Nozzle Temperature  
Indicates the temperature at the Drop Generator
- Electronics Temperature  
Indicates the temperature of the electronics
- Phase Position  
Is a number between 0-15 and indicates the position of Phase
- Phase Quality  
Indicates the quality of the phase return signal in a percentage
- Phase Range  
This shows the relative range the Phase is on the drops
- Pump Pressure  
Shows the actual pressure in psi or Bars (read by the Pressure Transducer)
- Pump RPS  
Shows feedback from the pump motor in rotations per second



## Event Log

The event log is a list of events of a combination of the previous Errors and Viscosity related actions with many additional printer events. The log is permanent and cannot be erased by Reboot.



The Event Log can be viewed in separate views of Error, Ink, Message, Misc., and All. Each event is Time and Date stamped.

10/26/2016 09:53:56 Mup Level OK  
10/26/2016 09:53:56 Ink Level OK  
10/26/2016 09:53:48 Printed 0 - Product 0  
10/26/2016 09:53:48 Start print message - Calibration Test  
10/26/2016 09:53:48 Printer start - 1.01m  
**10/25/2016 16:42:22 Printer shutdown**  
10/25/2016 14:50:21 Mup Level OK  
10/25/2016 14:50:21 Ink Level OK

Saving Event Logs can be saved to the on-board SD Card or a USB drive by selecting the [Files]  button, then select the device the file is to be saved and press the [Save Event Log]  button. These files can then be transferred to a PC for review and/or emailed.

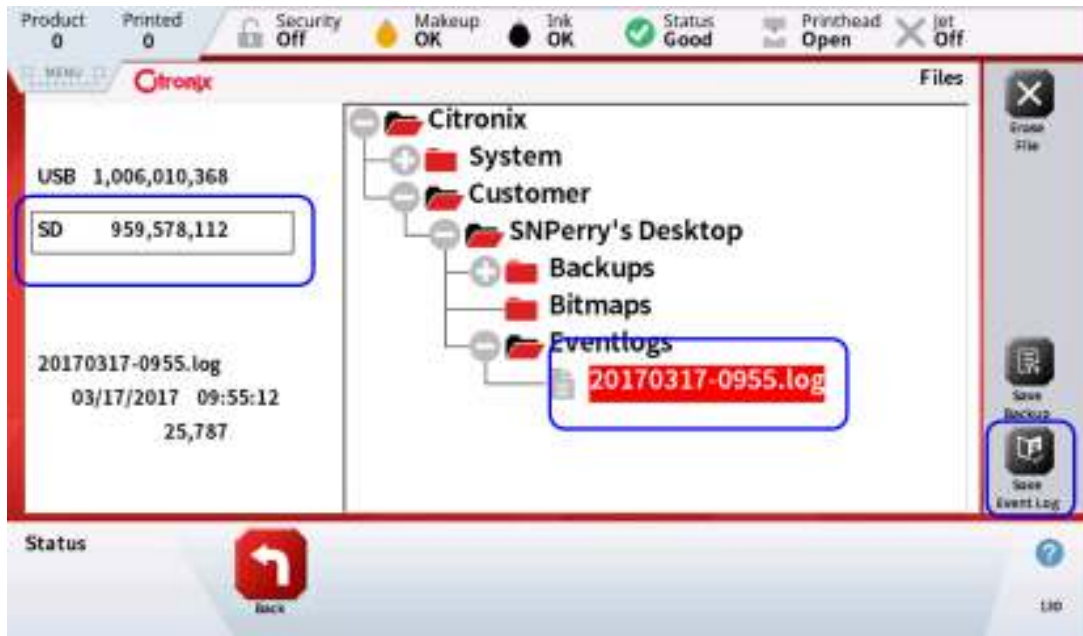

## Active Alarms

This screen displays any alarm/condition that is currently active on the printer.



## Viscosity Status

This screen displays all the viscosity status of the printer. Showing the expected, current viscosity in “Ball Fall Time” or Centipoise.

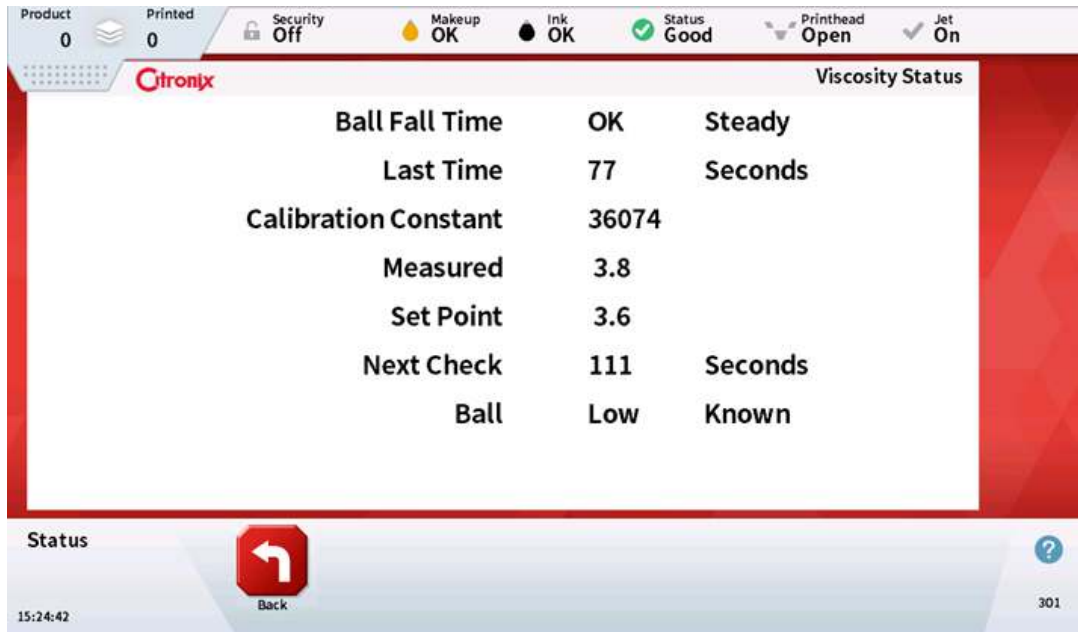

Field	Description	Options
Ball Fall Time	Shows status of viscosity	High, Low or OK Steady, Rising or Falling
Last Time	Ball drop time	Time in seconds
Calibration Constant	Calibration setting – calibration is obtained from the viscometer. Calibrated at factory.	Calibration number
Measured	Measured viscosity	Viscosity in CentiPoise
Set Point	Target viscosity	Viscosity in CentiPoise
Next Check	Time until next viscosity check	Time in seconds
Ball	Position of the ball	High or Low Known or Unknown

## Speed

This screen displays print speed information and when an Encoder is used, can help to properly “Dial in” the print speed so the width of the printed message does not change in length.

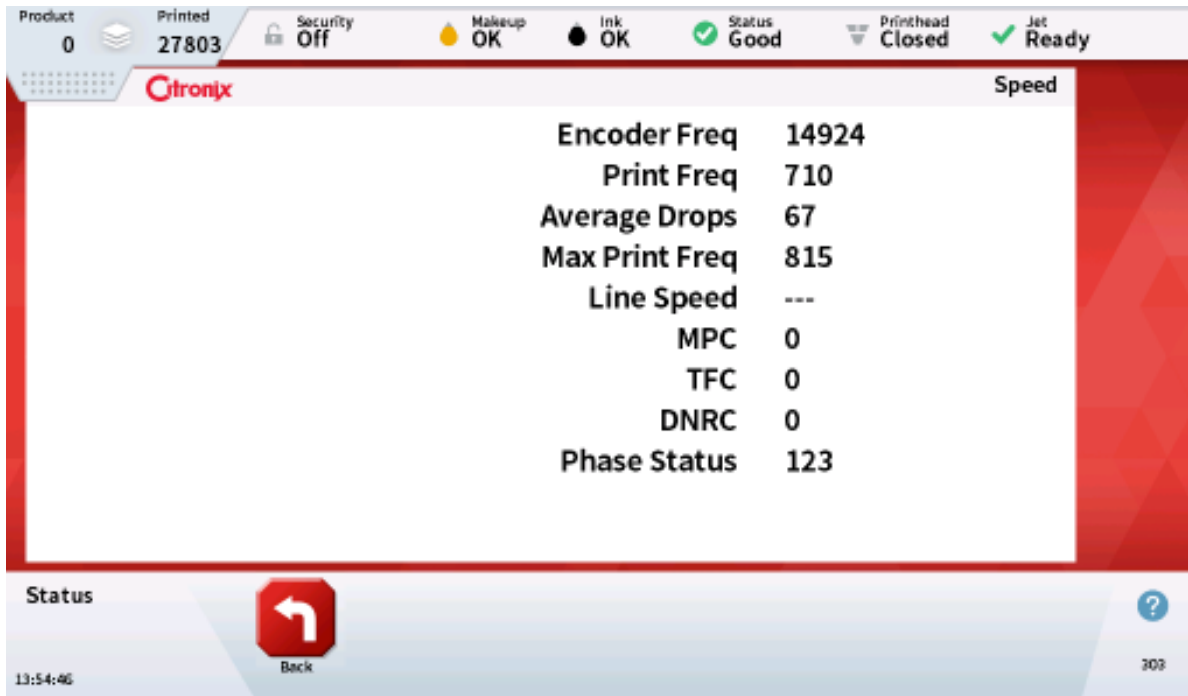

Field	Description	Options
Encoder Freq	Actual frequency of encoder	Frequency in DPI
Print Freq	Actual printing frequency	Encoder Freq divided by the product Width plus 1
Average Drops	Average number of drops used per raster of current message	Frequency in DPI
Max Print Freq	Maximum frequency the message can be printed with current settings and parameters	Drop Freq divided by Max Drops
Line Speed	Shows line speed based on product Length input on Applications Properties screen.	Speed Status
MPC	Missing Product Count. Message too large for the speed.	Count
TFC	Too Fast Count. Attempting to print faster than processor's capability.	Count
DNRC	Did Not Receive Count. In one-for-one mode, product was detected but the new message was not received.	Count
Phase Status	Printing too fast to phase	

**NOTE:** If the Print Frequency exceeds the Max Print Frequency, the message will 'stretch' and become longer than desired.

## Filters

This screen displays the status of the Service Module and Air filter in hours run and remaining.

See Section 6 "Cleaning and Maintenance" for further details.

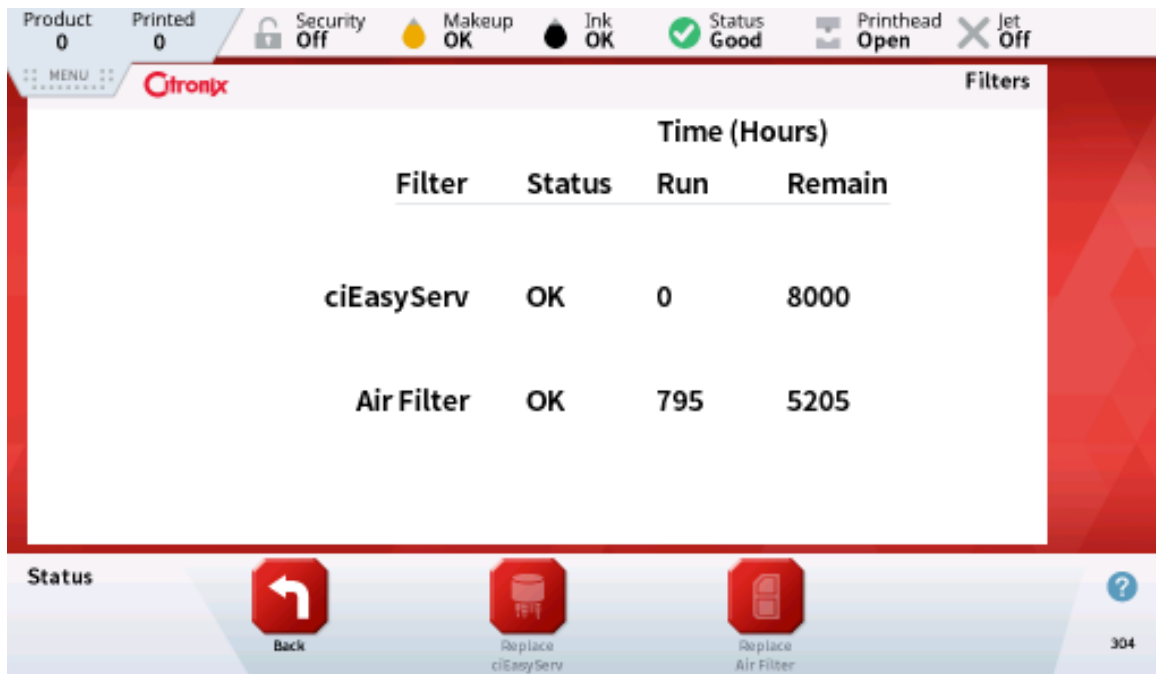

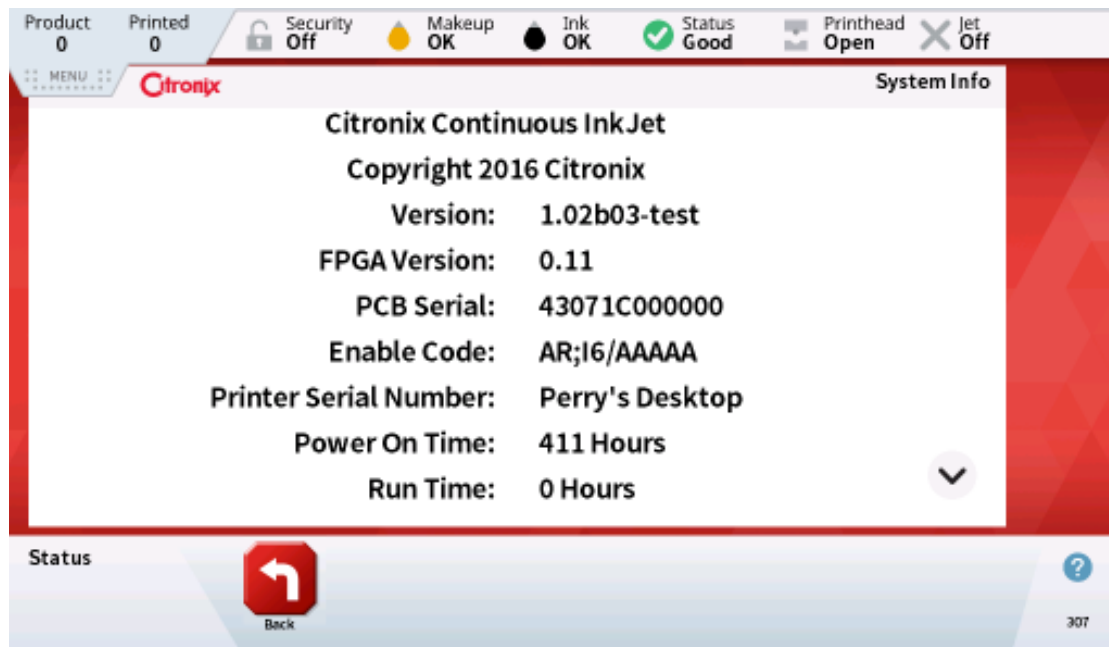

## System Info

There are 2 screens that contains some critical system information. The first screen has the Firmware Revision, CPU board information, Printer Serial Number, Power On & Run Time hours.



The second page will display the local Distributor Information such as Distributor Name, Contact Name, Telephone Number, and Email Address.

The Distributors may enter their contact information to be displayed on this screen by navigating to the [Service] screen  and then pressing [More] , then pressing the [Advance Service]  button.

After entering the Advance Service password use the command SCONTACT. Each of the four fields can then be edited.

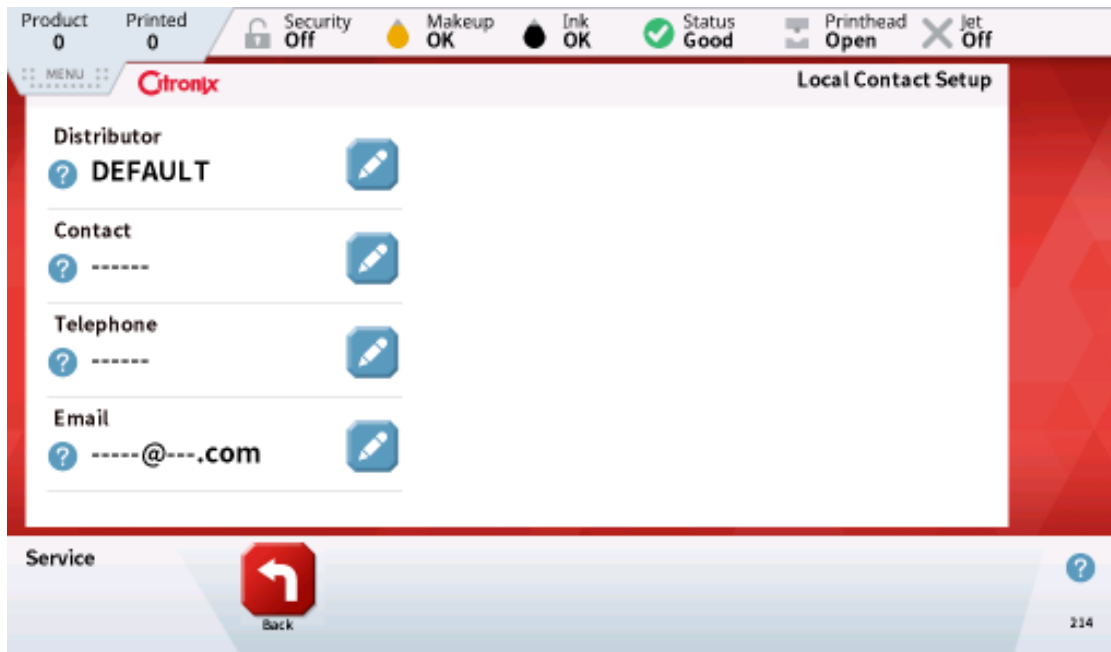

## SECTION 4: INSTALLATION AND COMMISSIONING

### CONTENTS

	Page
Unboxing the Printer.....	4-2
Mounting the Controller & Printhead .....	4-3
Printer Installation .....	4-3
Connecting Peripherals .....	4-4
Cabinet Connections.....	4-4
Accessories .....	4-5
External Wiring Options .....	4-8
Connecting External Power .....	4-10
Commissioning (Wizards).....	4-11

## Unboxing the Printer

The Citronix printer come securely packed in the box. Below describes what you see.

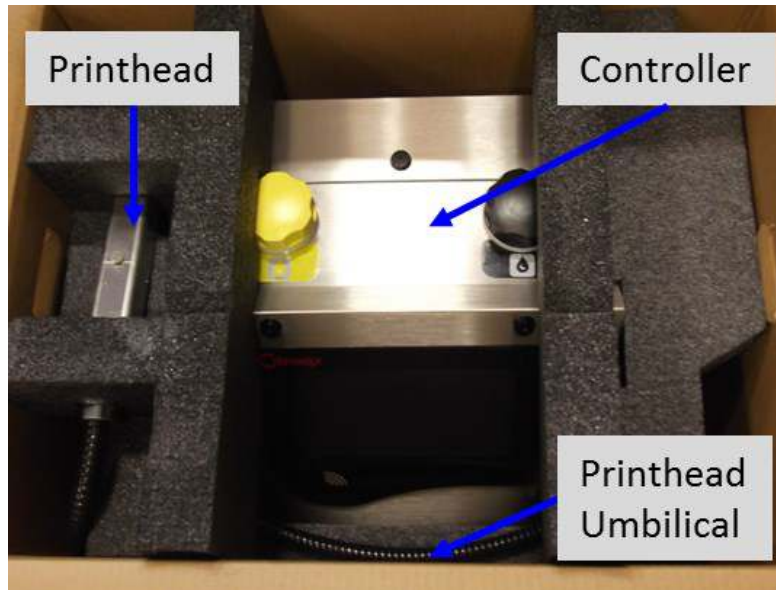

After opening, first remove the top 2 pieces of foam. These simply lift up and out. Remove the printhead as you remove the left piece of foam (as shown in the picture above). Gently lay the printhead on the floor and you continue to remove the printer from the box.



Lift the Controller by placing 1 hand on each side of the Controller underneath the cabinet at the Fill Port Caps (Black and Yellow Caps). Note the Hand Hold cutouts in the bottom foam.



Place the Controller on a sturdy/strong table or cart and place the printhead over the cabinet.  
Remove the Power Cord, QC sheet, and Printers Operations Guide from the bottom of the box.



## **Mounting the Controller & Printhead**

### **Printer Installation**

The following is general information for installing the printer in a wide range of working areas.  
The printer cabinet and printhead installation dimensions are given in the diagrams in Section 1.

### **Cabinet Positioning:**

Version 0.1

The cabinet should be in a position where there is access to the front, back, and sides with clearances to open the doors. The cabinet must be level and electrically isolated from other equipment, except for a normal data interface. For total stability, the printer should be mounted on a stand or table. The printer should be sited in an area where the temperatures will remain within +5°C and +45°C and the relative humidity will remain within 10% to 90% (non-condensing). The ci5200, ci5300, and ci5500 model printer draws in and expels air through the underside of the cabinet. Nothing must be allowed to interfere with this movement of air.

#### Conduit and Print Head Positioning:

The conduit must be kept away from power supply cables and other wiring capable of producing electrical noise. The print head must also be electrically isolated. This is normally achieved by the insulation coating on the printhead and its mounting components.

The print head and conduit must also be as free as possible from vibration.

Drop Size	Printhead distance from printing surface
Normal	3/4 inch (19mm)
Macro	3/4-1 inch (19-25mm)
HS50	1/2-3/4 inch (12-19mm)
Micro	1/4-3/8 inch (6-9mm)

The print head must be mounted perpendicular to the printing surface. The distance between print head and print surface is optimized to the values given above. Print quality will be maintained if the distance is between the limits given, but will reduce outside these limits.

## **Connecting Peripherals**

### **Cabinet Connections**

The 5000 Series printers come with IP65 rated standardized accessory connectors for:

- Encoder
- Photocell
- Beacon



This prevents mistakes while connecting peripheral accessories by having different pin-outs for each. Making easier and faster printer installations as well as making it fast and easy to swap a printer between multiple production lines.

## Accessories

### Photocells:



**015-2020-001**  
**Photocell, Fiber Optic Proximity Diffuse**  
**(IP65 Connector)**



**015-2021-001**  
**Photocell, Fiber Optic Through Beam Opposing (IP65**  
**Connector)**



**015-2022-001**  
**Photocell, Proximity Diffuse (IP65 Connector)**  
**Includes:**  
- Banner N6/IP67  
- 15ft (4.5M) Cable  
- Bracket & screws  
- NPN Open Collector Output



**015-2023-001**  
**Photocell, Retroreflective (IP65 Connector)**  
**Includes**  
- Banner N6/IP67  
- 15ft (4.5M) Cable  
- Bracket & screws  
- NPN Open Collector Output  
- LED Status Indicator

Encoder:



**015-2006-003**  
**Encoder Kit, Shaft (IP65 Connector)**

- Includes:**
- 9ft (3M) Cable
  - IP65
  - Spring Bracket

Beacon Options:



**015-2026-001**  
**Beacon, Alarm, Single Stage (IP65 Connector)**

- Includes:**
- Warning light(s)
  - 9ft (3M) Cable
  - Stand Mount Kit



**015-2027-001**  
**Beacon, Alarm Dual Stage (IP65 Connector)**

- Includes:**
- Warning light(s)
  - 9ft (3M) Cable
  - Stand Mount Kit



**015-2011-003**  
**Beacon, Alarm 3 Stage (IP65 Connector)**

- Includes:**
- Warning light(s)
  - 9ft (3M) Cable
  - Stand Mount Kit

## External Wiring Options

External Connectors and pin-out drawings for Accessories not offered by Citronix:



- 020-1083-001  
Connector, External 3-pin male, encoder
- 020-1085-001  
Connector, External 4-pin male, photocell
- 020-1087-001  
Connector, External 7-pin male, beacon

### PC1 (Photocell) 4 pin plug

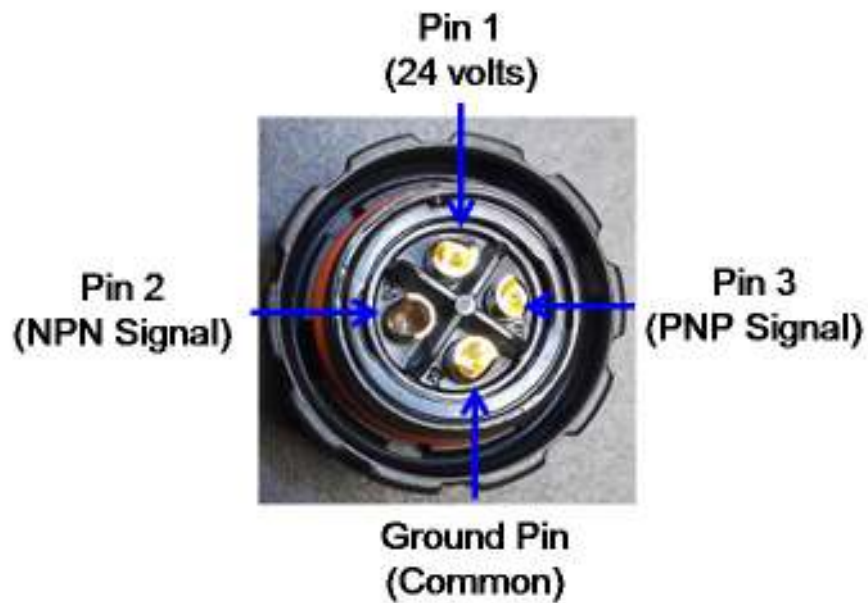

## Encoder 3 pin Plug

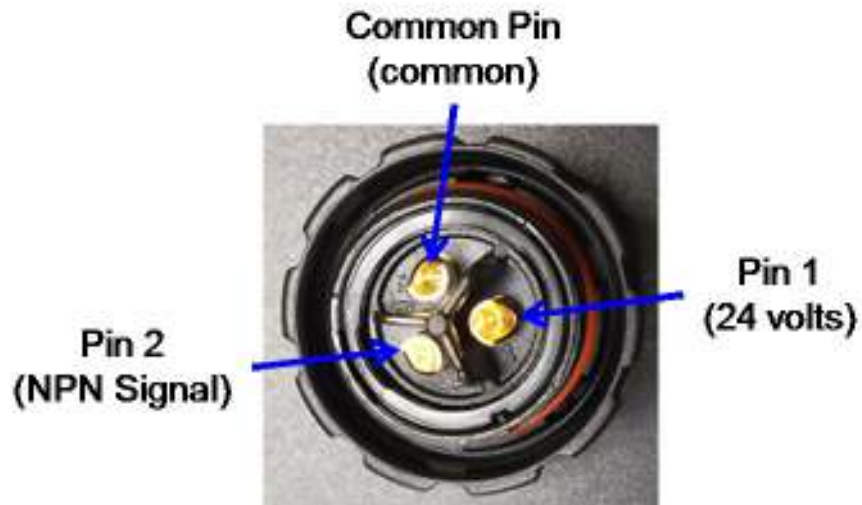

## Alarm Beacon 6 pin

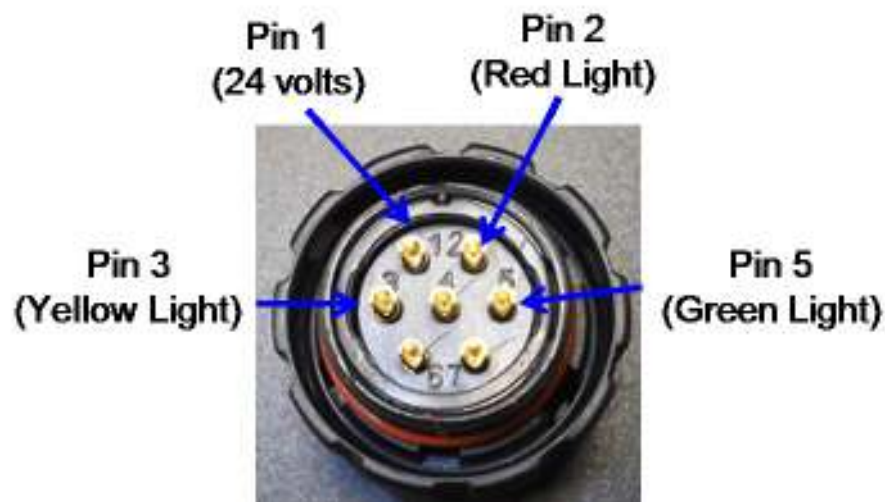

## Connecting External Power

Connect the power cord to a suitable power source as indicated below:

Single Phase - 90VAC (3 amp) to 260VAC (1 amp)

Frequency - 50/60 Hz

The socket-outlet should be installed near the equipment and be easily accessible. The Power outlet should be on a dedicated line and not shared with other machines or motors. The Power should be checked with a Multi-meter for proper wiring/voltage prior to plugging the printer in.

The 5000 Series Printers currently ship with either a standard U.S., European, United Kingdom, Chinese, or Japanese Power cord. If you need a power cord with a different type of plug, we recommend purchasing a power cord approved by local government or identified with an HAR (Harmonized Standard) label.

**NOTE:** To help protect and ensure reliable performance from your Printer, Citronix recommends the use of a surge suppressor or line conditioner for uninterruptible power supply and dedicated line from the main power source.

**WARNING:** The Printer must be properly grounded to a good earth ground point.



## Commissioning (Wizards)

When the printer is initially powered up, the printer will automatically run a series of Commissioning Wizards. These wizards are design to enable the user to properly setup the printer.

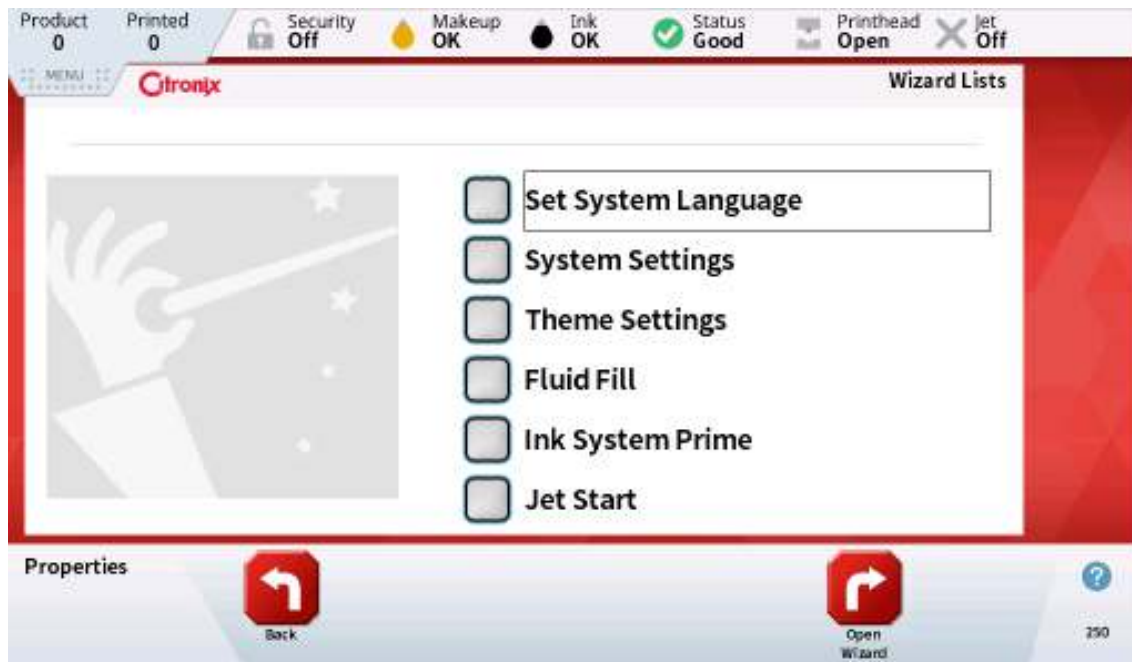
**DO NOT SKIP THESE WIZARDS!**



### 1<sup>st</sup> Wizard (Set System Language)

This wizard will guide the user to select the preferred language the printer's firmware will use for all operations of the printer. Simply press the [Open Wizard]  button in the Navigation Tool Bar at the bottom of the screen to display/select the Language list. Press/select the language required and press the [Select Language]  button in the Function Tool Bar on the right of the screen.



The firmware will change back to the Wizard List screen showing this step has been completed.





2<sup>nd</sup> Wizard (System Settings)

Next select the next wizard (System Settings) and press the [Open Wizard]  button.



The System Settings Wizard will take the user through a 8 step process to setup the date and time as well as all the formats to be used.

Pressing the [Edit]  button next to each option will allow the user to adjust/set each option. Using the numbers keypad, enter the desired date/time and press [Save]  button to move to the next step. When all 8 steps are complete, press the [Next Step]  button to save and exit to the Main Wizard menu.







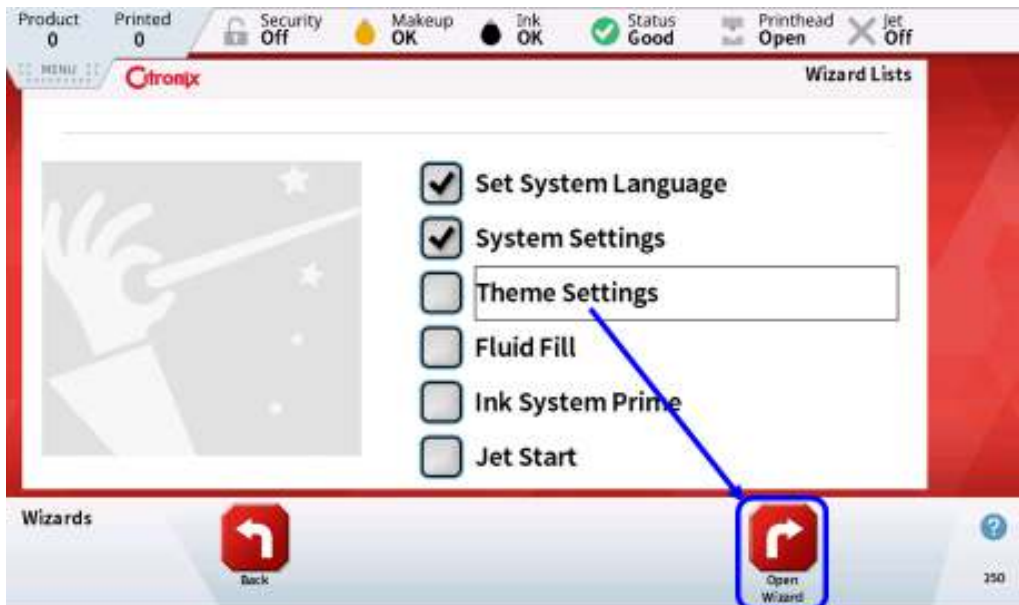

### 3<sup>rd</sup> Wizard (Theme Settings)

This 2 step wizard enables a large visible banner on the Home Screen and selects the Theme Color of all the screen backgrounds (Red or Blue are the only options).

***NOTE:*** This will cause the printer to reboot to set. After the reboot, the Wizards will pick back up where it left off.



Pressing the [Edit]  button next to each option will allow the user to set each option. Select from the list and press [Select] , then press the [Next Step]  button to move to the next step. When the 2 steps are complete, press the [Next Step]  button to save and exit to the Main Wizard menu.



Red Home Screen  
no Banner



Red Home Screen  
with Banner



Blue Home Screen  
no Banner



Blue Home Screen  
with Banner

4<sup>th</sup> Wizard (Fluid Fill)

This wizard will prep the printer with fluids (Ink & Make-up).

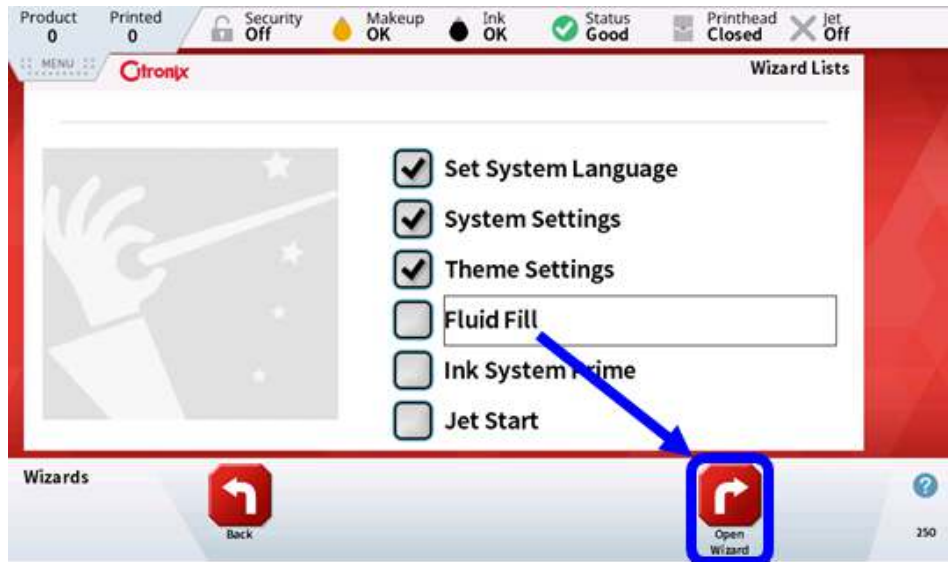

2 of the steps in this 6 step wizard, will ask to present the bottle tags to the reader BEFORE installing onto the printer. This validates the right fluids are being put in and at the right time. At this time it also resets the run hours for each fluid. Just follow the instructions on each screen.

**Note:** When the Tag is requested, the wizard will not continue until the tag is read. If too much time has been taken before presenting the tag, you may have to press the [Previous Step]  button to restart the reader.

(Ink Fill)

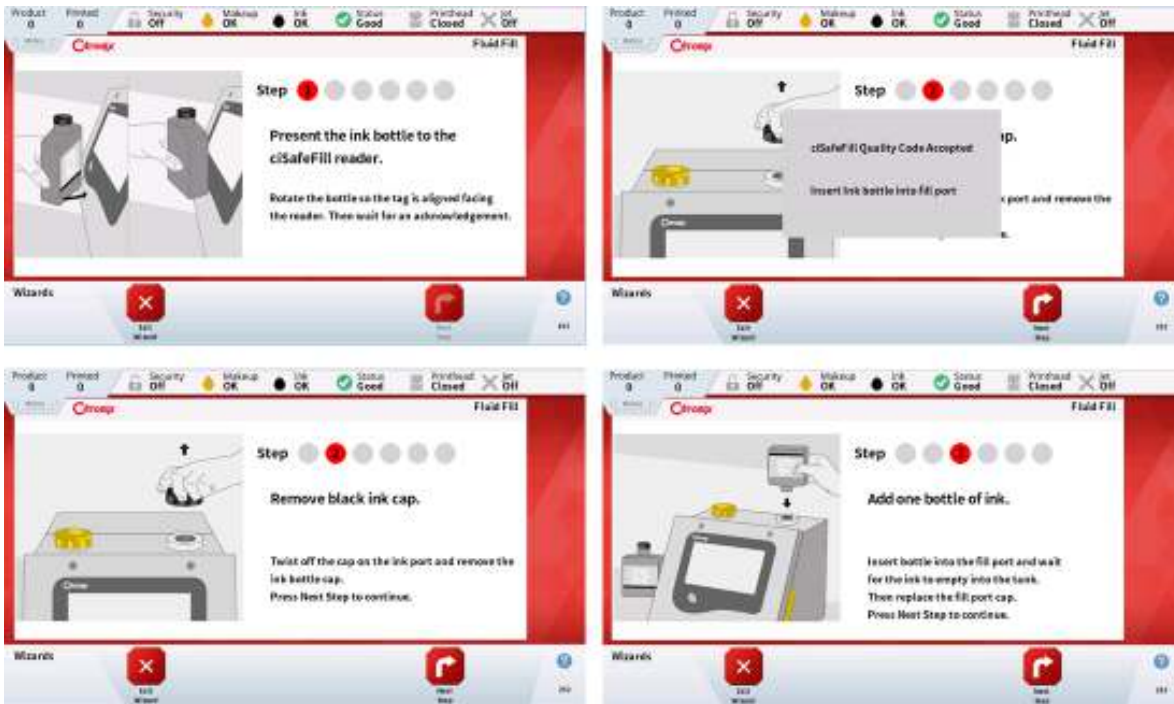

(Make-up Fill)

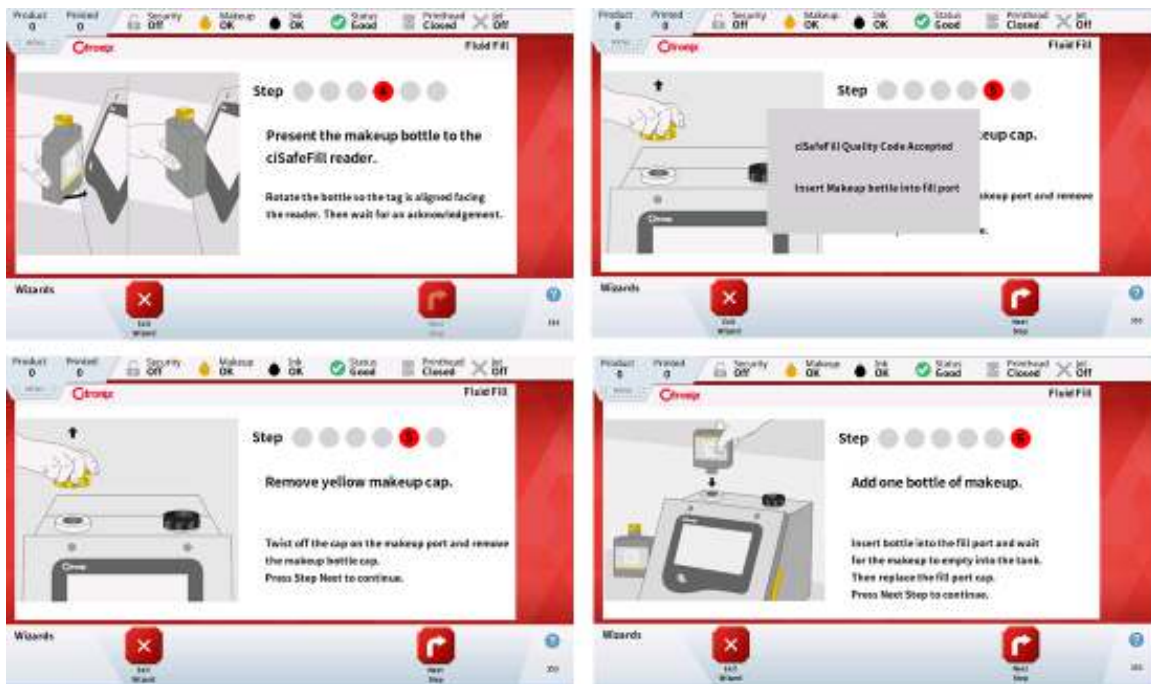

After the 6 steps are complete the firmware will move back to the Wizard Main menu showing the step as completed.



5<sup>th</sup> Wizard (Ink System Prime)

Next press Ink System Prime and then press [Open Wizard] .

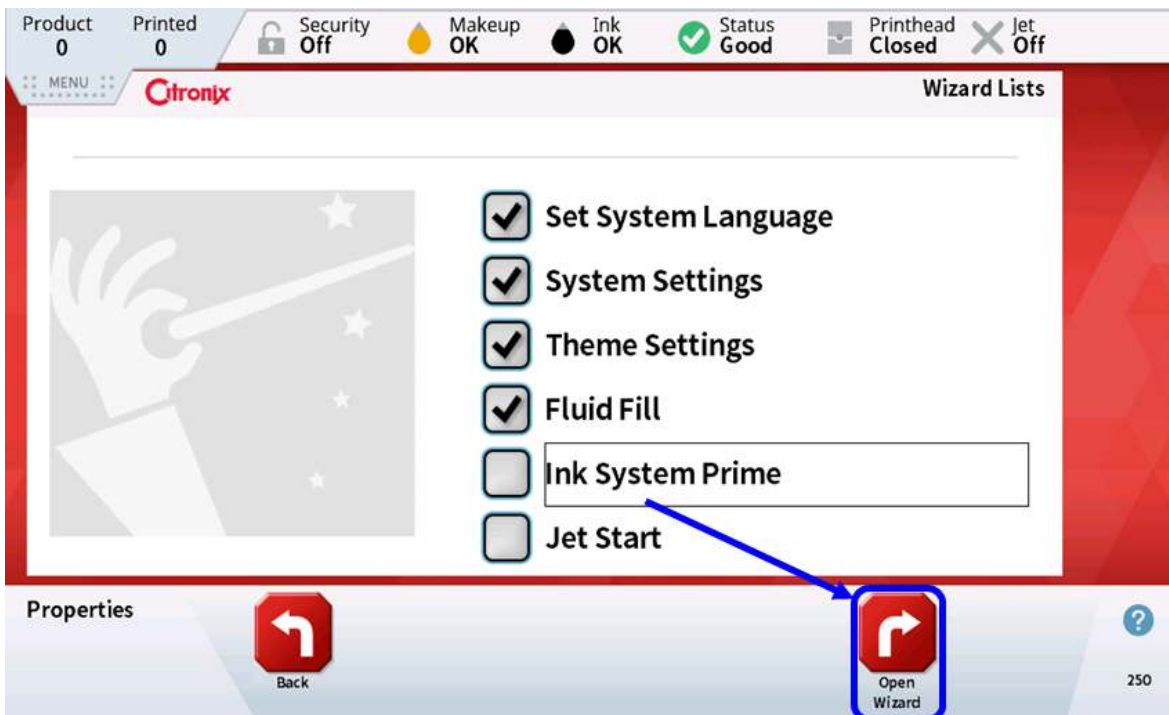

This 6 step process will correctly prime the ink system and affectively bleed out the air.



Follow the instructions on the screen and proceed to the next step when directed.



After the 6 steps are complete the firmware will move back to the Wizard Main menu showing the step as completed.



6<sup>th</sup> Wizard (Jet Start)

Next press Jet Start and then press [Open Wizard] .



This wizard will move ink through the Printhead and jet ink out the Nozzle into the gutter. Remove the Printhead cover and have a beaker, paper towels, squirt bottle of Cleaning Solvent, protective clothing and eye wear to handle any initial Ink Jet missing the gutter.

This 3 step process will start the Ink Jet to allow the user to correctly identify the printhead alignment. For more details on jet alignment see Section 9 “Calibration”.

Follow the instructions on the screen and proceed to the next step when directed.



After the 3 steps are complete the firmware will move back to the Wizard Main menu showing the step as completed.

All of the Wizards have been successfully completed, press the [Back]  button to return to the Home Screen. The printer is not ready to use. Please allow at least 2 hours of jet run time to allow the ink viscosity to reach the optimum thickness.



## SECTION 5: STATUS BAR/TROUBLESHOOTING

### CONTENTS

	Page
Introduction.....	5-2
Red Alerts.....	5-2
Amber Alerts.....	5-2
Fault Acknowledgement.....	5-2
Alert / Status Bar Messages.....	5-3
Printer States.....	5-3
Status: Jet Calibrating.....	5-4
Status: Jet Off.....	5-4
Status: Start Jet.....	5-5
Status: Jet On.....	5-5
Status: Jet Ready.....	5-6
Printer Faults.....	5-7
Print Quality Faults.....	5-9

## **Introduction**

The Alert / Status Bar display's a quick view of the printer status and information to the user.

### **Red Alerts**

Red alerts are shown by a flashing red LED indicator on the alert switch and a corresponding message displaying in the status/alert bar. They show the presence of faults and stop the printer printing or prevent an unsafe condition occurring.

The jet will shut off (without following the normal sequencing). If the fault condition is still present when acknowledged, the red LED will remain on and the alert bar message will continue to show. If the fault condition has cleared when acknowledged, the red LED will extinguish and the message will be removed.

### **Amber Alerts**

Amber alerts are used to inform the operator that the printer is in need of attention or that there are message handling errors. If the fault condition is still present when acknowledged, the amber LED will remain on and the alert bar message will show. If the fault condition has cleared, the amber LED will extinguish and the alert bar message will be removed.

### **Fault Acknowledgement**

Depending on the alert, some messages are automatically cleared when the condition is cleared although they will remain in the fault log list until the user has acknowledged them (if the alert does not disappear from the list when acknowledged, it means the problem still exists). If two or more alerts exist simultaneously, the highest priority alert is displayed. All reports are recorded in the error log, together with times of acknowledgement and repair.

## Alert / Status Bar Messages

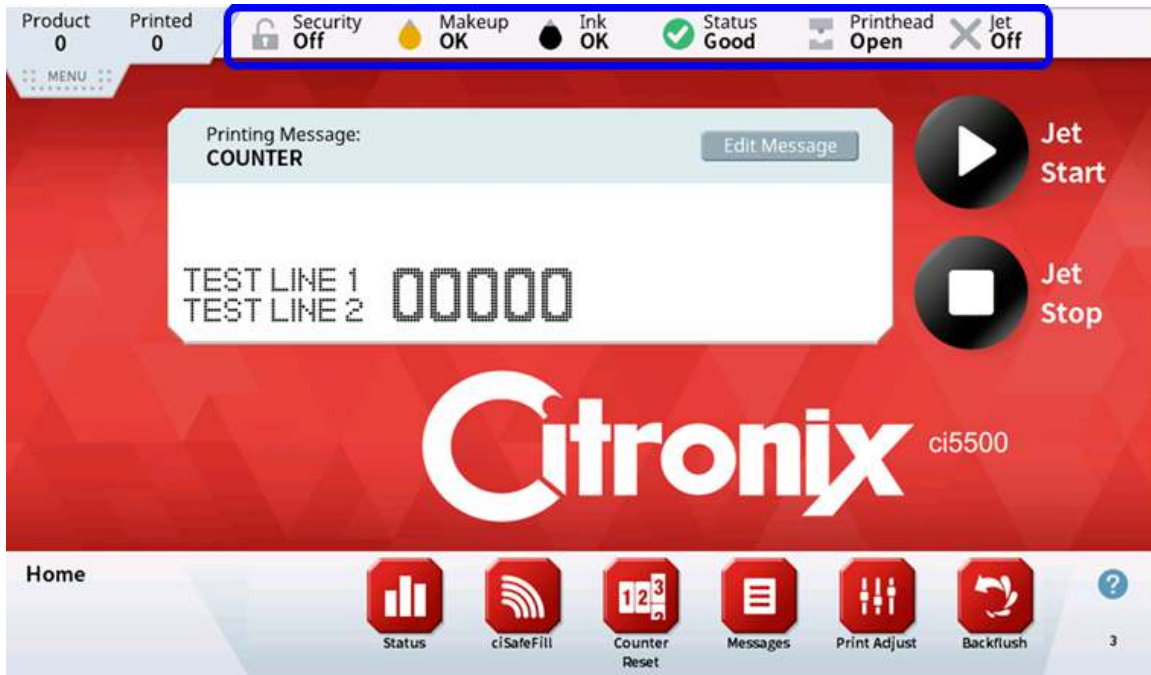

## Printer States

Shown below are some of the more common printer states, these will be shown in the status/alert bar at the top of the screen:

Overall Printer Status		Jet Status	
	Printer Status Good		Jet calibrating
	Printer Status Warning		Jet Off
	Printer Status Error		Jet Starting
Security Status			Jet Running (Print Enabled but HV not on)
	Security Enabled		Jet Paused (Print Disabled but HV not on)
	Security Disabled		Jet Ready (Print Enabled and HV ON)
Printhead Status			Jet Paused (Print Disabled and HV ON)
	Printhead Open		Jet Stopping
	Printhead Closed		Jet Stirring
Fluids Status			
	Makeup Level High		Ink Level High
	Makeup Level OK		Ink Level OK
	Makeup Level Low		Ink Level Low
	Makeup Level Empty		Ink Level Empty

### Status: Jet Calibrating

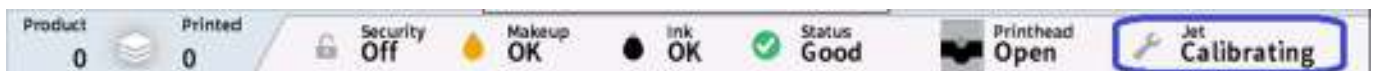

### Status: Jet Off

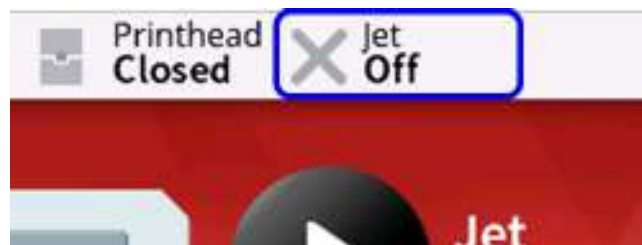

## Status: Start Jet



**NOTE:** when the jet is starting the Text to the right of the “Start” button will flash black and white, also a countdown will start on the bottom left of the screen while the system is starting.

## Status: Jet On

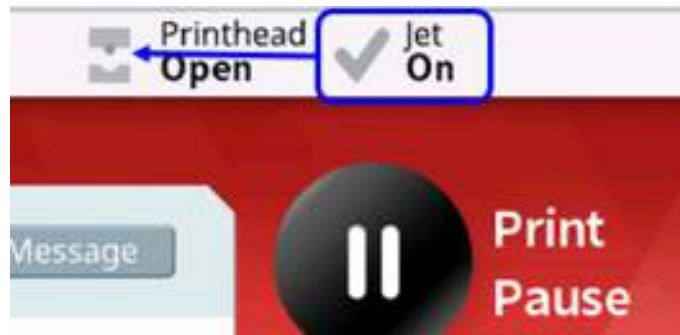

**NOTE:** The above picture shows the jet status with the printhead cover off

## Status: Jet Ready

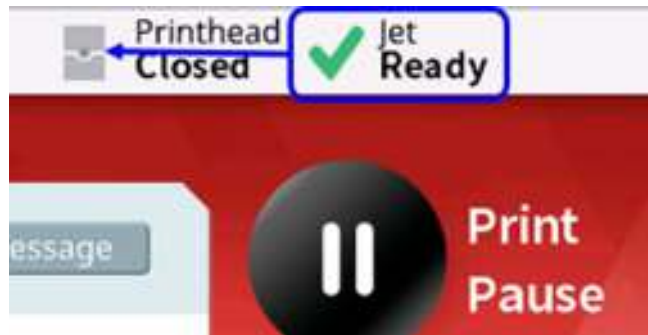

In this Status, the Deflection Field is activated and the printer will print the message selected with each print signal.

## Printer Faults

The following problems can have the suggested causes and remedies.

Fault / Issue	Possible Cause / Fix
No Power	<ol style="list-style-type: none"> <li>1. Check the power to the unit.</li> <li>2. Check the Power Switch.</li> <li>3. Check the Mains Fuses.</li> </ol>
Power on – No Display or Display Rolling	<ol style="list-style-type: none"> <li>1. Check the display connection to the CPU</li> <li>2. Press the MENU key; this acts as a display reset.</li> <li>3. This error could be due to a possible Electro-Static Discharge fault; reset the Printer.</li> </ol>
Pressure High Error	<ol style="list-style-type: none"> <li>1. Check Restrictor(s) for clogs.</li> <li>2. Check Return Line to Ink Tank for clogs.</li> <li>3. Check Pressure Transducer (possibly an incorrect reading).</li> </ol>
Pump Motor Error	<ol style="list-style-type: none"> <li>1. Check the Fuses.</li> <li>2. Check the Pump Cable.</li> <li>3. Disconnect the Pump Head and perform a pump motor test (described below).</li> <li>4. Check the Pump Head for a seizure (if the motor operates).</li> </ol>
Cooling Fan Error	<ol style="list-style-type: none"> <li>1. Check the Fuses.</li> <li>2. Check the wire cable for damages if the fan is turning.</li> </ol>
Phase Error	<ol style="list-style-type: none"> <li>1. Check for Ink stream breakup.</li> <li>2. Check the distance from the Ink stream to the Phase Detector.</li> <li>3. Ensure the Ink stream is in the center of the Charge Electrode.</li> <li>4. Check the pressure and viscosity (to verify Jet velocity).</li> <li>5. Check the location of the Phase Amplifier to make sure it is NOT too close to the Valve, Valve wires, or other possible source of noise. (See Section 9.2.3 Phase Detector Alignment)</li> <li>6. Check the Phase Amplifier connections.</li> <li>7. Ensure you are not printing too fast (add print delay)</li> </ol>
Charge Error	<ol style="list-style-type: none"> <li>1. Check for Ink stream breakup (see Section 10.8).</li> <li>2. Check the modulation calibration.</li> <li>3. Clean and dry the Phase Detector.</li> <li>4. Check the distance from the Ink stream to the Phase Detector (see Section 10.7).</li> <li>5. Check the charge cable continuity from the Charge Electrode to CPU.</li> <li>6. Check for clogged Filters.</li> <li>7. Check pressure and viscosity (to verify Jet velocity).</li> <li>8. Check the gold charge contact located under the charge electrode block. (shown below without connecting wire)</li> </ol>
No Ink Stream Breakup	<ol style="list-style-type: none"> <li>1. Check the F2 Fuse.</li> <li>2. Check for correct printing. If printing, check strobe LED connections.</li> </ol>

Fault / Issue	Possible Cause / Fix
Gutter Error	<ol style="list-style-type: none"> <li>1. Check the alignment of the Jet. Ensure the ink stream is going into the gutter.</li> <li>2. Listen for a steady vacuum.</li> <li>3. Check continuity of the gutter sensor to the CPU.</li> </ol>
Printhead Temperature Error	<ol style="list-style-type: none"> <li>1. Check the Nozzle temperature in the Status Screen.</li> <li>2. Check the temperature probe connections in the top of the Printhead.</li> </ol>
No Deflection Voltage	<ol style="list-style-type: none"> <li>1. Ensure the Printhead cover is closed and the HV symbol is displayed on the main screen.</li> <li>2. Check the low voltage connections from the CPU to the HV module.</li> <li>3. Check the connection of the red HV wire to the HV module.</li> <li>4. Check the continuity from the HV deflection plate to the end of the HV wire at the HV module.</li> </ol>
Electronics Temperature Error	<ol style="list-style-type: none"> <li>1. Ensure the fan is operating.</li> <li>2. Ensure the Air filter is not clogged (replace if needed).</li> </ol>
High Voltage Trip	<ol style="list-style-type: none"> <li>1. Verify the HV Trip set point.</li> <li>2. Ensure the Deflection Plates are clean and dry.</li> <li>3. Watch for Ink buildup due to lack of grounding.</li> <li>4. Check the Jet alignment.</li> </ol>
Modulation Error	<ol style="list-style-type: none"> <li>1. Check for Ink stream breakup.</li> <li>2. Check for any tripped fuses.</li> <li>3. Ensure that Printhead components are clean and dry.</li> <li>4. Check the continuity of the Resonator Probe.</li> <li>5. Verify the modulation calibration.</li> </ol>
High Viscosity Error	<ol style="list-style-type: none"> <li>1. Ensure all the Fill caps are on tight.</li> <li>2. Check the Makeup Add Valve for operation.</li> <li>3. Ensure the Makeup Filter is primed.</li> <li>4. Verify the Viscometer Calibration Constant is the same as stated on the Calibration Label located inside the front door.</li> </ol>
Low Viscosity Error	<ol style="list-style-type: none"> <li>1. Verify the Viscometer Calibration Constant is the same as stated on the Calibration Label located inside the front door.</li> <li>2. Ensure the Makeup Add Valve is not stuck open. This error will also be indicated if the Ink tank is overfull while the Makeup tank is in a low status.</li> </ol>
Viscometer Sensor Error	<ol style="list-style-type: none"> <li>1. Verify the Viscometer Calibration Constant is the same as stated on the Calibration Label located inside the front door.</li> <li>2. Check the operation of the Viscometer Valve.</li> <li>3. Ensure the ball is moving (use a test sensor).</li> <li>4. Check the operation of the sensor - observe the LED9 on the CPU board.</li> </ol>
Ink Leaking From Gutter (poor vacuum)	<ol style="list-style-type: none"> <li>1. Check the adjustment of the Venturi. (see Section 6/Service Routines/Changing/Cleaning the Venturi Restrictors)</li> <li>2. Check that the restrictors are the correct type.</li> <li>3. Ensure the restrictors are not clogged.</li> <li>4. Verify the Jet alignment.</li> <li>5. Check the gutter tube connections (inlet &amp; outlet) under the Service Module.</li> <li>6. Reseat or replace the Service Module</li> </ol>

## Print Quality Faults

1. A dirty printhead
  - a) Please review Section 5.2 Printhead Cleaning
2. Dirty nozzle
  - a) See Section 5-4 Backflush Routine
3. Poor or misadjusted printhead alignment
  - a) Contact your local Service Technician
4. Ink out of viscosity
  - a) Ensure the proper ink and Make-up are used
  - b) Contact your local Service Technician
5. Needing recalibration
  - a) Contact your local Service Technician

The following are examples of faulty printing. In most cases, further investigations should begin with ensuring that the printhead is clean and properly aligned.

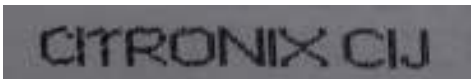
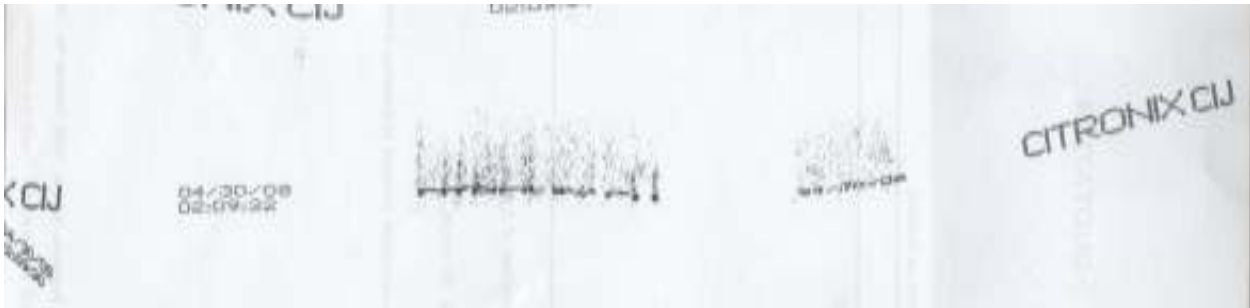

## SECTION 6: **CLEANING AND MAINTENANCE**

### CONTENTS

	Page
Cleaning and Maintenance.....	6-10
Proper Printhead Cleaning.....	6-10
Backflush Routine.....	6-12

Replace/Clean Air Filter: .....	6-13
Service Module Replacement:.....	6-14
Error .....	6-15
Clear Error .....	6-16
Stop the jet .....	6-16
Service Module Verification.....	6-17
Fault Finding & Repair:.....	6-20
Service Routines .....	6-53
Backup & Restore .....	6-53
Firmware Updating.....	6-60
Loading Fonts, Languages, and Keyboards .....	6-63
Uploading Graphics .....	6-65
Changing/Replacing a CPU Board.....	6-67
Changing or Cleaning a Nozzle Plate .....	6-70
Ultrasonically Clean a Nozzle Plate .....	6-71
Charge Electrode Block Alignment.....	6-71
Changing Ink, Makeup or Ink, Makeup Tank (Ink Refresh).....	6-72
Changing the Ink System Pump.....	6-73
Changing / Cleaning an Ink System Valve and Gasket .....	6-74
Changing / Removing the Pressure Transducer.....	6-75
Changing / Cleaning the Pressure Restrictor .....	6-75
Changing / Cleaning the Venturi Restrictors.....	6-77

## **Cleaning and Maintenance**

### **Proper Printhead Cleaning**

The Printer will operate for a considerable time before the Printhead will require cleaning. However, peak operating performance and reliability will only be maintained if the Printhead is cleaned on a regular basis.

To check and clean the Printhead:

1. Stop the Jet by pressing the Stop Button.



2. Release the thumbscrew securing the printhead front cover and slide off the cover.



3. Check inside the Printhead cover for a buildup of Ink deposits. If there are any deposits, clean the inside of the cover using the Cleaning Solvent compatible with the type of Ink being used.
4. Check the Printhead for buildup of Ink deposits and when necessary, use the appropriate Cleaning Solvent compatible with the type of Ink being used. Pay particular attention to the Nozzle Plate, Charge Electrode, Phase Detector, HV Plates and Gutter Block.
5. Use a suitable container to catch the excess Cleaning Solvent and dispose of it in accordance with local regulations

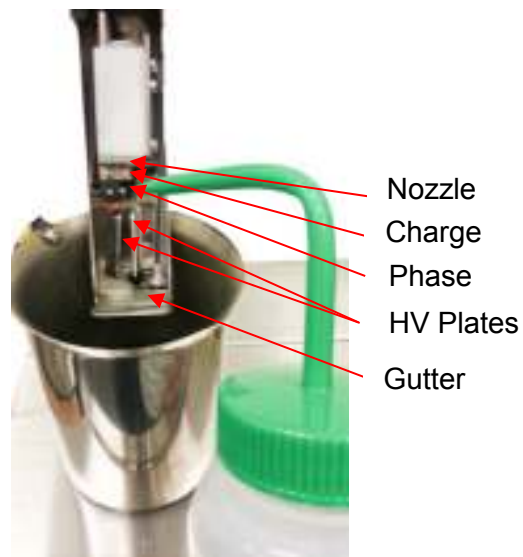

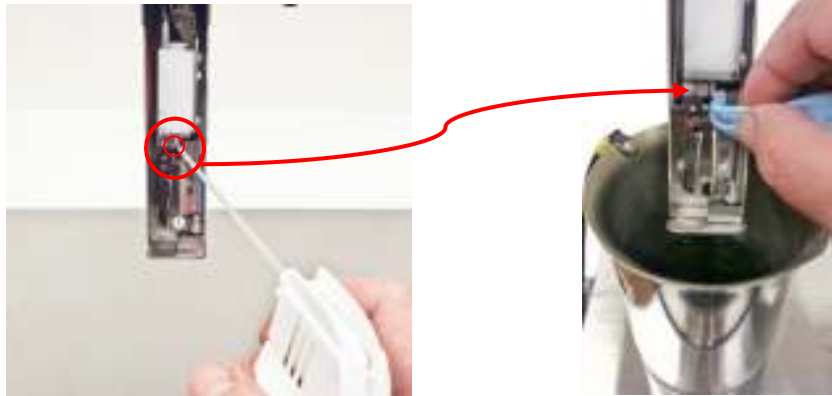

Low-pressure dry, clean air

6. Allow the Printhead to dry, ensuring that the slot in the charge electrode is clear of Cleaning Solvent.
7. Refit the Printhead cover and tighten the thumbscrew.







**PERSONAL INJURY:** Make sure the Printhead is completely dry before attempting to start the Jet. Use lint-free cloths or low-pressure dry clean air to dry the Printhead. Do not use high-pressure air or cloths or paper towels containing lint waste.

## Backflush Routine

In the event the Jet does not start correctly after a Printhead cleaning, a Backflush Routine can be performed to clear partial or complete Nozzle blockages.

To perform a Backflush Routine:

1. Stop the Jet by pressing the Stop Button 
2. Once the printer has completely shut down, locate the [Backflush]  button in the Navigation Tool Bar on the main screen.
3. Release the thumbscrew securing the Printhead front cover and slide the cover off.
4. Press the Backflush button. The Printer will create a vacuum from the Nozzle until either the [Cancel]  button in the Function Tool Bar, or by pressing the [Back]  button in the Navigational Tool Bar, or the 60 second countdown timer has expired.
5. Spray the appropriate Cleaning Solvent into the Nozzle in 10 second intervals. Observe the Cleaning Solvent being vacuumed through the Nozzle.



Spray Cleaning Solvent into Nozzle

6. After 10 seconds, press the Cancel button in the function Tool Bar to stop the process.
7. In the unlikely event this does not resolve the problem, repeat the process up to 10 times. If the problem persists, contact a maintenance technician.

### Replace/Clean Air Filter:

Depending on the environment the printer is operating, it may be necessary to clean or replace the air filter on a regular interval.

The Air Filter is located on the right-hand side of the cabinet. To clean or replace the Air Filter:

1. Remove the Air Filter (yellow cover together with the filter element).



2. Remove the filter element by unclipping or unsnapping the filter element. Tilt or twist the yellow cover to release one side of the handle then twist in the opposite direction to release the second side as shown below.

Filter element



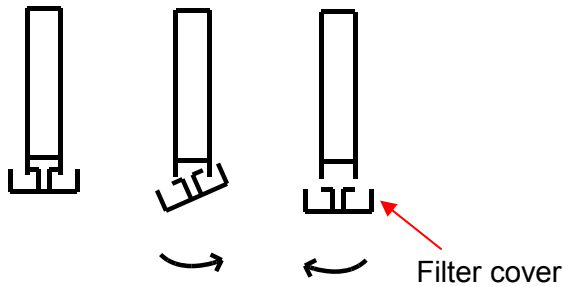

3. Gently tap the dirty side of the filter or use a vacuum to suck the dirt from the filter OR replace the filter.
4. Reattach the filter element to the yellow cover by reverse the process. Snap the 4 slots on the filter element over the 4 hooks on the yellow cover.
5. Replace the Air Filter by inserting it back into the slot. Make sure the notch is toward the top when inserting the Air Filter.



***NOTE:*** Clean the Air Filter regularly between routine maintenance schedules. Depending on air quality of the environment, it may be necessary to clean the Air Filter weekly. To do this, gently tap the filter element to remove dirt or use compress air to blow air through the filter element in the opposite direction to the normal flow.

## **Service Module Replacement:**

The ci5000 series printers introduce ciEasyServ: a quick, easy, no mess/no fuss, tool free service module. It combines all of the serviceable fluid filters into one self-enclosed module with leak-free fittings. This easy replacement method reduces the risk of damaging fittings and causing leaks in the printer. This section describes when and how to replace the ciEasyServ module shown below.



## Error

This error will appear in 3 stages to allow enough scheduling time to allow the printer to be shut down for replacement so that this does not interfere with normal production runs.

They are as follows:

1. The first error/warning will appear when the Service Module reaches 288 jet running hours left before expiring. This error/warning will reappear once a day. Usually at startup or in case of a 24/7 operation, the same time each day that it initially appeared.
2. The second error/warning will appear at 144 jet running hours left. This error/warning will reappear once an hour until the next stage is reached.
3. The third error/warning will appear when there is 48 jet running hours and less left. This error/warning will reappear every 5 minutes until zero (0) hours are reached.
4. This is the final error/warning and will appear when the module hours have reached zero (0). At that time the printer will perform a controlled shutdown and will not run until the Service Module is replaced and a new tag scanned resetting the hours.

When the Service module has expired an error warning is presented as shown below.



### Clear Error

Press the [OK] button to clear the error as shown above. The following screen will display the hours remaining. When ready to replace the Service Module first ensure the jet and pump are off (see below).





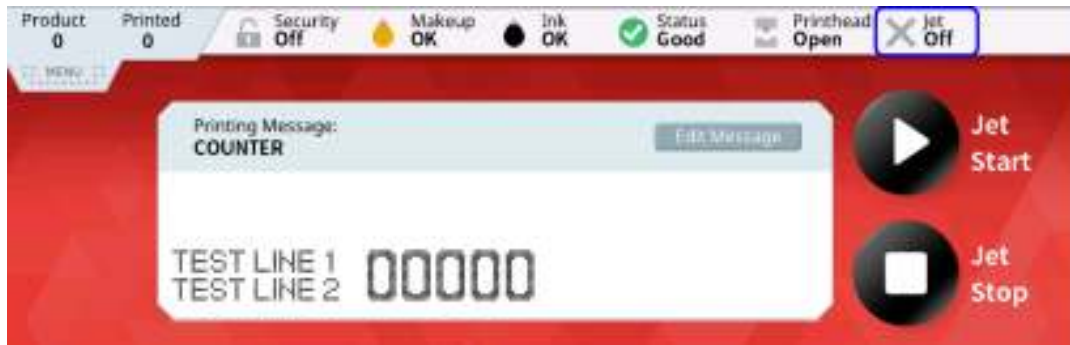

### Stop the jet

Press the [Stop]  button. A countdown will appear in the bottom left hand corner of the Main screen and “Jet Stop” will flash black/white while the system is stopping. When the printhead has completed the proper shutdown the Jet icon in the top bar will show “Off”.



## Service Module Verification

Press the [Menu Tab] , then [Status]  button, and then press [Filters]  button in the Navigation Tool Bar. Then press the [Replace ciEasyServ]  in the Navigation Tool Bar to start an automated replacement wizard (ensure a new Service Module is readily available before pressing the Replacement button ). Present the Tag on the Service Module to the reader symbol on the Touch Panel as depicted on the screen.



When the Tag is approved remove the back cover as instructed on the next 2 steps.

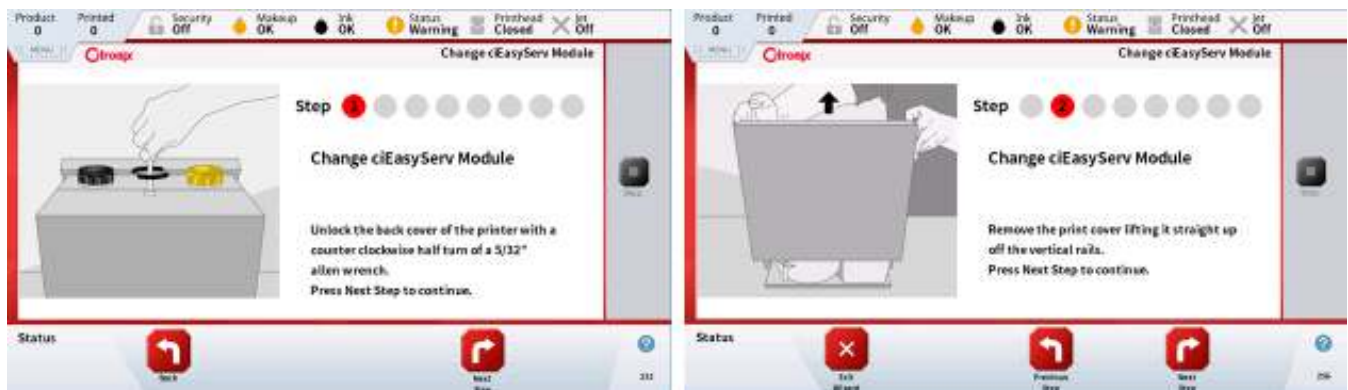

Remove the old and insert the new Service Module.

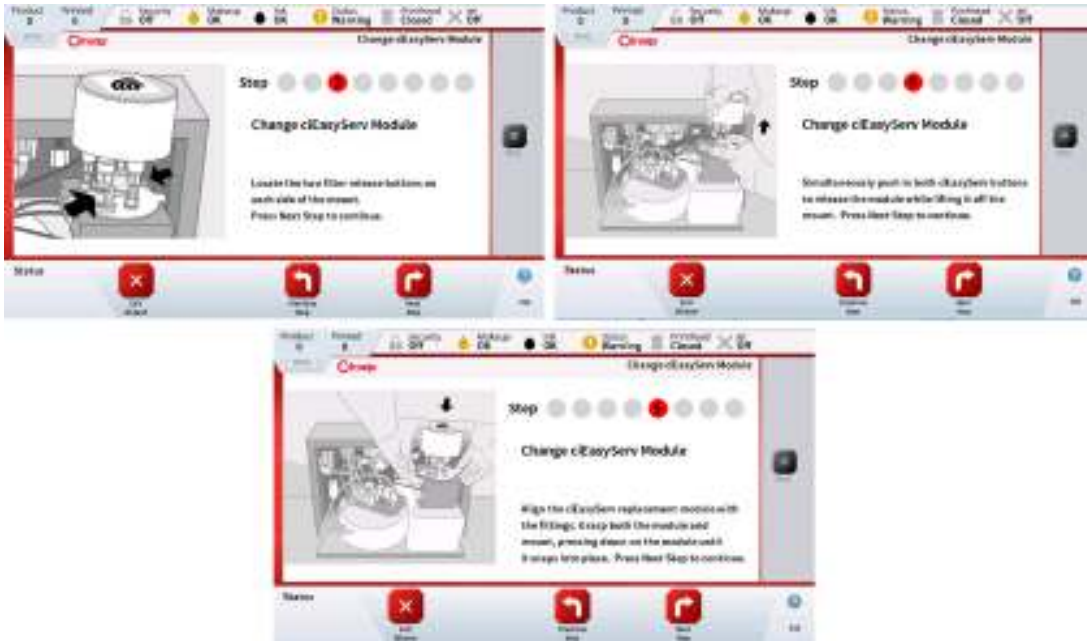



Once the new Service Module has been fitted, Press the [Next] button in the Navigational Tool Bar at the bottom of the screen. This will start a 3 step automated prime sequence.



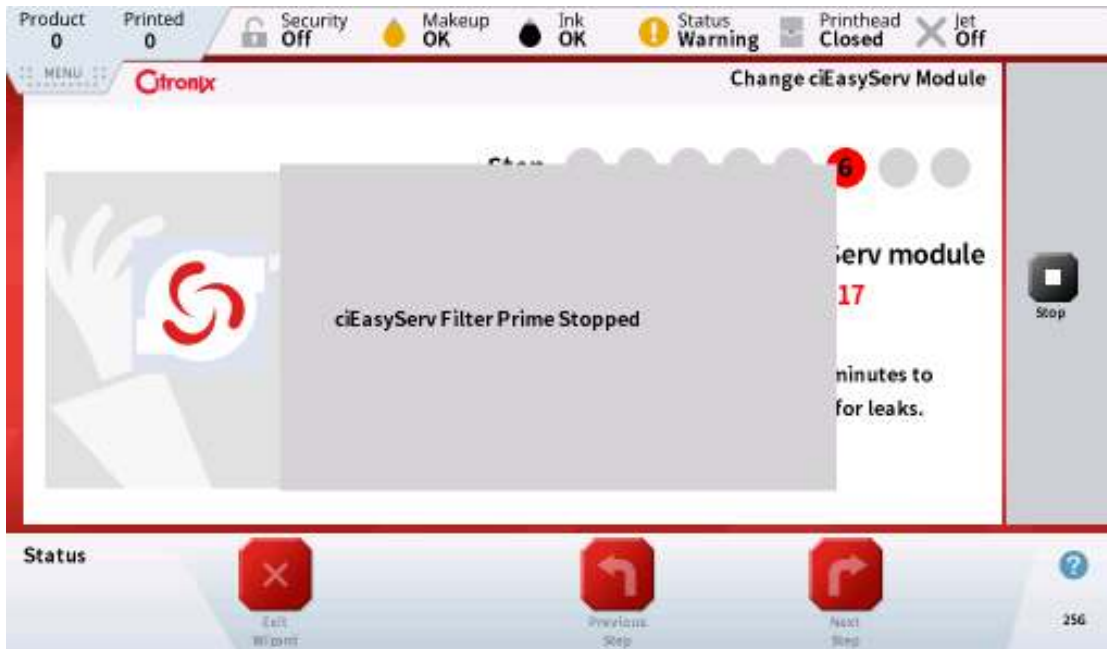

As the priming sequence starts, monitor the connections at the Service Module for any Leaks. If a leak is seen, press the [Stop]  button and fix the leak. The screen below will be displayed.

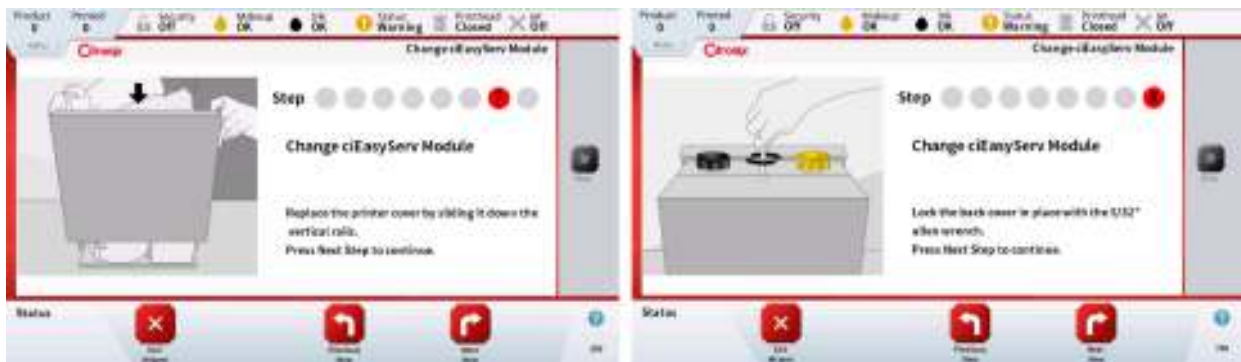

then press [Next Step]  on the screen to restart the priming sequence.

When this final priming sequence is finished press [Next]  to continue. Following the screen instructions, refit the back cover.



Once the last screen is complete and the user has pressed the [Next]  button, the screen will change back to the Main filter screen showing the hours reset (seen below). Press the [Back]  button 2 times to return to the Main Home screen. Press the Jet Start button to now continue to run the printer.



**NOTE:** The Replace ciEasyServ button is greyed out when the filter change has been properly completed.

**NOTE:** The amount of filter hours will vary depending on the environmental conditions

## Fault Finding & Repair:

### Cooling Fan Error

#### Definition:

The cooling fan keeps circulation inside the printer cabinet. The fan sends a signal to the CPU board indicating the fan is turning. If the signal is not received this error/fault will be displayed.

#### Corrective Action:

1. 24V EXT fuse is open (Reset Power)– this can be caused by connecting external peripherals incorrectly.
2. The fan is not connected.
3. The fan actually does not turn.
4. The fan cable is faulty or damaged.
  - a. Check tach wire connection for a loose fit in connector
    - i. Push wire into connector
  - b. Check tach wire for damage
  - c. Replace fan assembly
5. External peripheral has been shorted – PC, SE, Alarm, etc.
6. Fan cable has three 3 wires
  - a. Red – power
  - b. Black - ground

- c. Yellow – tach output



## Air Pressure Error

### Definition:

The ci5650 printer utilizes plant air to cool and pressurize the printer cabinet and to supply positive air to the printhead. A factory air supply with a minimum of 25 psi (1.7 bar) air should be supplied to the air system mounted to the right-hand side of the ci5650 Printer. The air system will regulate the pressure to 15 psi (1 bar), separate out the moisture and filter the air.

When this pressure is not sensed at the pressure sensor this error/fault will be displayed.

### Corrective Action:

1. Check the incoming plant air is on and at a minimum of 25 psi (1.7 bar) by checking the air gage on the Regulator on the right side of the printer. (See picture below)
2. Check/change the air filters
3. Empty the water from the separator
4. Check for air at the cabinet air inlet
5. Check the Pressure Switch is connected
6. Check the Pressure Switch signal is closing when air is applied. Replace if needed.

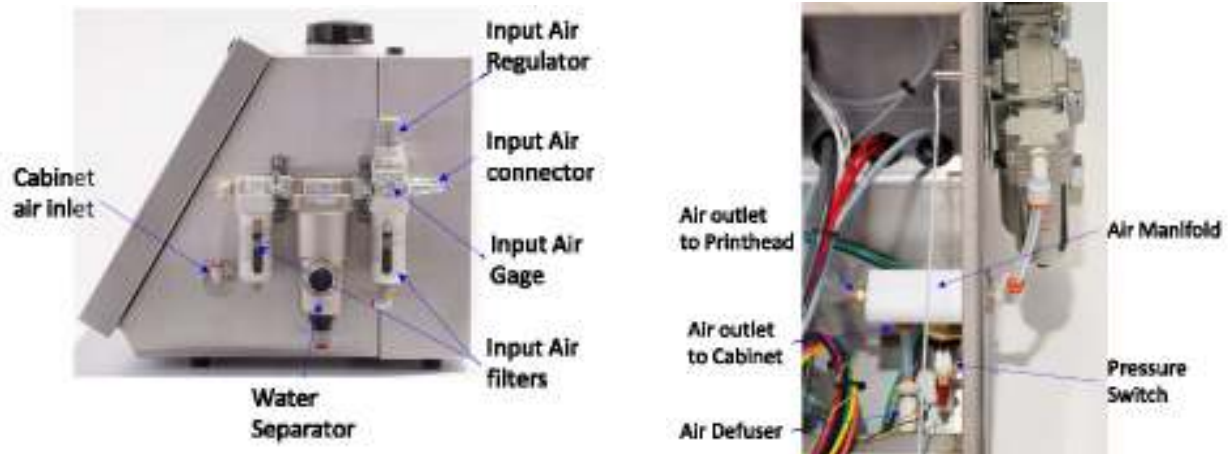

## Phase Error

### Definition:

Phasing synchronizes the printing system and ensures that each drop contains a full charge. Phase values change constantly with variations in viscosity, temperature or elevation of the Printhead. It also makes adjustments when the components such as Nozzle or Resonator Probe or fluids are changed.

Phasing takes place between prints (characters, messages, etc.) or between printed strokes (in very slow printing). The Phase Error occurs when the Phase Quality drops below 40%.

### Corrective Action:

1. Ensure the Phase Detector And Charge Electrode is not covered with ink, clean and dry if necessary.
2. Check for Ink stream breakup.
3. Check the distance from the Ink stream to the Phase Detector. (see Fig 1)
4. Ensure the Ink Stream is centered to the Phase Detector. (see Fig 2)
5. Check the pressure and viscosity (to verify Jet velocity).
6. Check the location of the Phase Amplifier to make sure it is NOT too close to the Valve, Valve wires, or other possible source of noise. (see Fig 3)
7. Check the Phase Amplifier connections.
8. Ensure you are not printing too fast (add print delay)

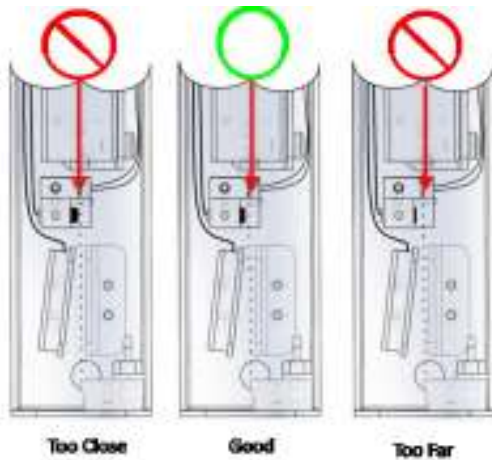

Ink will get on detector Phase Quality of 90-100 Phase Quality below 90

Fig 1

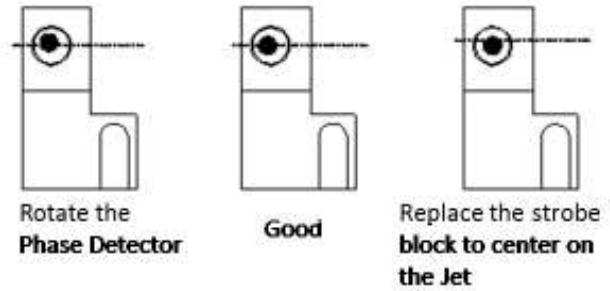

Fig 2

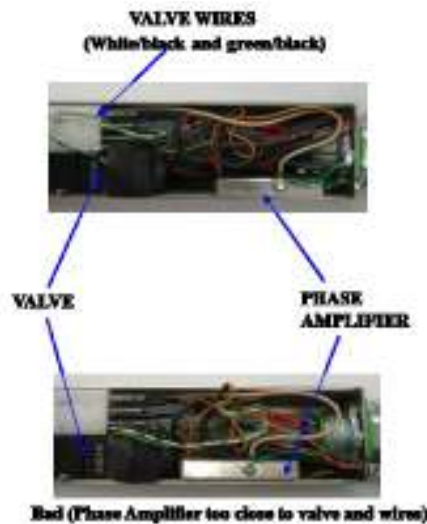
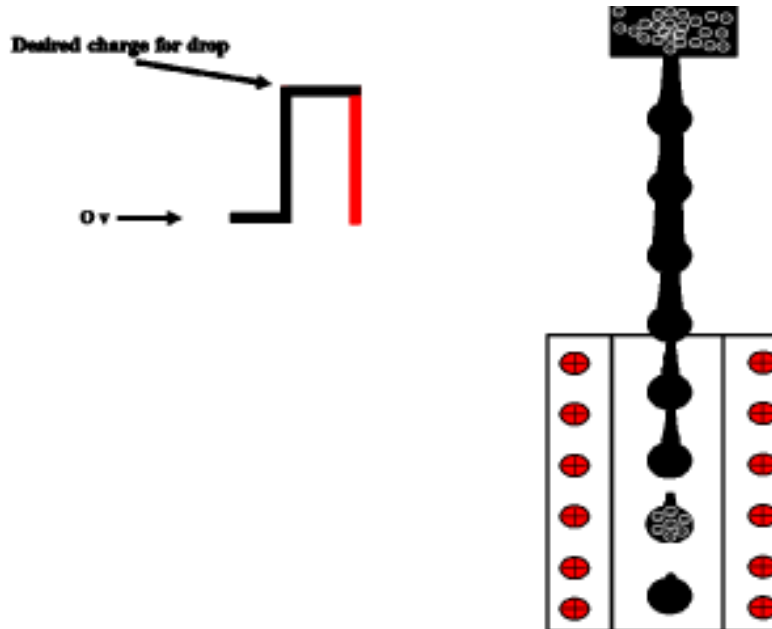

Fig 3

## Printhead Charge Error

### Definition:

Charge Electrode charges the ink drops. When a Positive charge is applied to the Charge Electrode Electrons are attracted from the Drop generator (Earth). When the drop breaks off the excess electrons are trapped. The drop will have a Negative charge proportional to the voltage applied to the C/E.



### Corrective Action:

If you receive a Printhead Charge Error, check the following:

1. Drop velocity. The error can be caused by:
  - a. Pump pressure and RPS (high or low).
  - b. Filter status (clogged/dirty).
  - c. Ink viscosity (high or low).
2. A dirty Printhead, Phase Detector & Charge Electrode is covered in Ink.
3. Poor breakup/modulation:
  - a. No breakup. Check Modulation Cable/Fuse.
  - b. Satellites, ligaments (very long tails on the drops) or not breaking off in the center of charge electrode.
  - c. Incorrect modulation. Check settings against factory settings label.
4. No charge applied. Check charge cable.
5. Incorrect ink stream alignment thru the Charge Electrode. Must be centered. See Fig 1 & 2 below.
6. Check the gold charge contact located under the charge electrode block. (shown below without connecting wire - Fig 3)

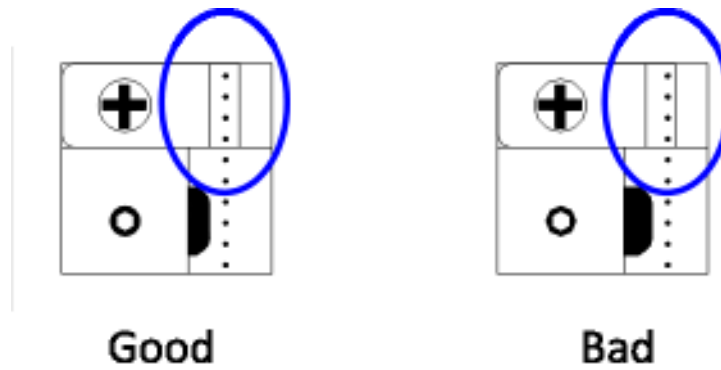

**Fig 1**

To realign loosen the 2 screws securing the Strobe Block assembly and move to center then tighten screws. See picture below.

**NOTE:** *do not overtighten the screws. This can cause damage to the Printhead chassis.*



**Fig 2**



**Fig 3**

## Definition:

Ink travels from the Nozzle Plate thru the Charge Electrode and then passes between the Deflection Plates. Unprinted drops are collected in the gutter block and travels up the gutter tube back to the Ink Tank to be reused. This ink passes thru a sensor (5 inches or 12.7cm for the Standard printhead & 2 inches or 5cm for a Micro printhead) that senses ink in the gutter. It does this by the conductive ink shorting the sensor to ground (printhead chassis). If ink is not detected (ink stream missing the gutter hole) or the ink is diluted (by rinsing the ink off the Gutter Block while the ink stream is on) this error/fault will be displayed.

## Gutter Sensor



## Corrective Action:

If you receive a Gutter error:

1. Check the alignment of the Jet. Ensure the ink stream is going into the gutter.
2. Listen for a steady vacuum.
3. Check continuity of the gutter sensor to the CPU.

## Ink Reservoir Full



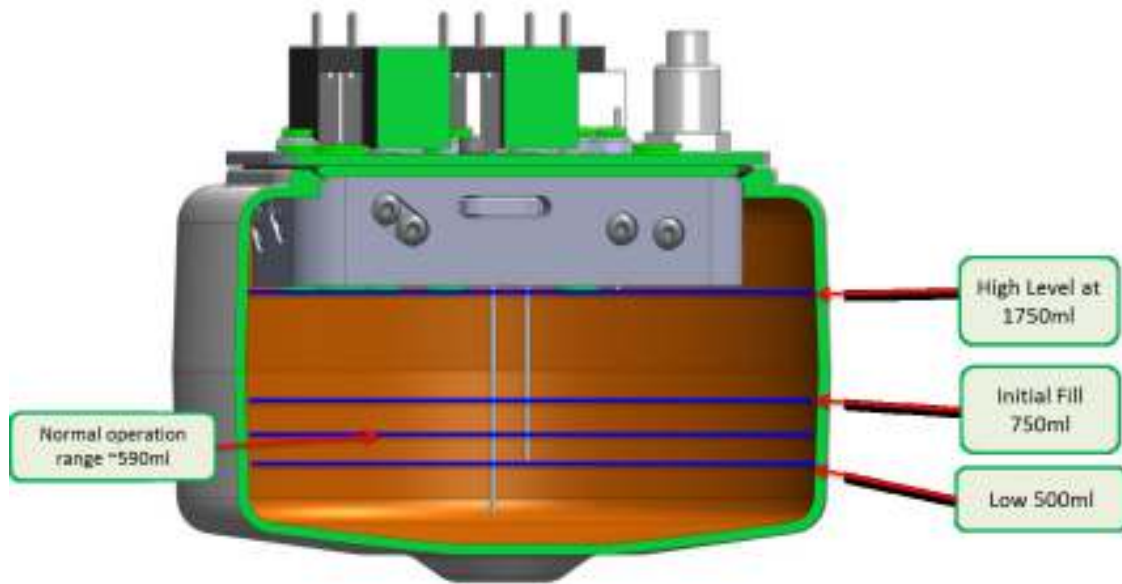

### Definition:

The Ink Tank level is monitored continuously with 3 level rods to maintain the optimum level of ink. When the ink level gets to the "High" level sensing rod, there will be ~1750ml of ink in the tank. This will send the "Ink Reservoir Full" error/fault and will shut the printer down. This is to prevent ink from spilling out causing a hazardous condition. The normal operating level is between 600 to 500ml. This allows ample room to add Make-up to control the viscosity. See Fig 1 below.



**Fig 1**

**Corrective Action:**

1. Inspect the ink level thru the tank and ensure the level is in fact high.
  - a. If not high
    - i. check the level rod wires for continuity back to the CPU board...if good
    - ii. replace the CPU board
2. If the level is high, remove ink by:
  - a. Ensure the pump is off
  - b. From the main screen press the [Menu]  tab and then select [Service] .
  - c. Press [Run Pump] .
  - d. Remove the inlet pressure tube from the manifold (Fig 1 below) and place in a beaker
  - e. Press the [Increase]  button 2 times to start the pump.
  - f. Pump ink from the Ink Tank until the level is at or below the mid-level seam of the ink tank. (See Fig 2 below)
  - g. Once this level is achieved press the [Cancel]  button.
  - h. Reinsert the inlet pressure tube back into the Ink Manifold ensuring the tube is fully inserted.
  - i. Dispose of the ink properly according to local regulations.

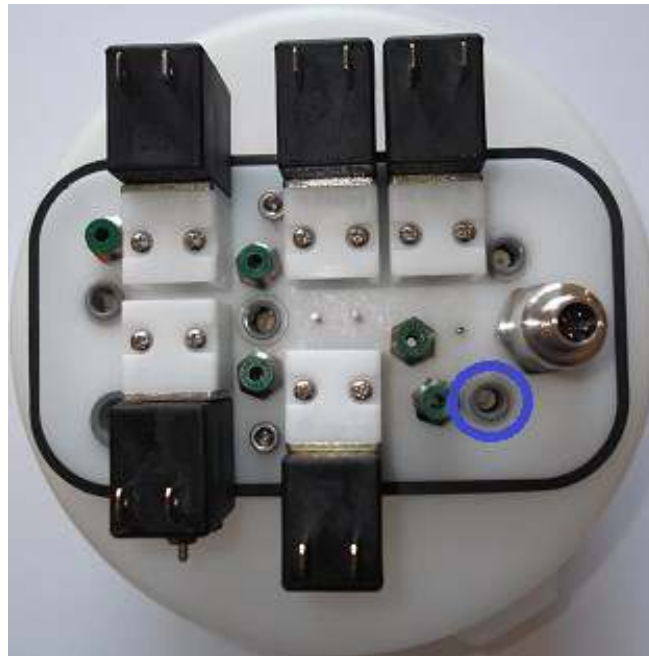

Fig 1







Fig 2

## High Voltage Trip

Definition:

A variable high voltage output of 0V to 8000 V at 120i amps is provided to establish the electrostatic field between the Deflector Plates in the Printhead. If the Deflection plates are shorted, this error/fault will occur. This can happen if there is ink or solvent on the Positive/Angled plate. If the printhead was just cleaned with solvent and not properly dried the solvent can short the plate causing the error/fault. Also is ink builds up on the Positive/Angled plate and reaches any grounded surface of the printhead like the gutter block or other plate, this too will cause the error/fault. This buildup can be caused by improper modulation, excessive vibration, Static, scratches on either of the plates, etc.

### Corrective Action:

1. Clean and dry the plates. (See Section 6 Proper Cleaning Procedure)
2. Check for scratches on both HV Plates
3. Verify the HV Trip set point by starting from the main screen press the [Menu]  tab and then select [Service] . Press the [HV Trip]  button in the Navigational Tool Bar. Note the setting or recalibrate the setting by making sure the HV Plates are clean. Ensure the Printhead Cover is on. Then press the [Automatic]  button. This sequence will take about 30 seconds.  
When finished press the [Back]  button 2 times to return to the Main Screen.
4. Watch for Ink buildup due to lack of grounding.
5. Check the Jet alignment. (See Section 9: Calibration for the proper jet alignment procedure)
6. Ohm the 22M resistor & replace (if needed) the HV Sense Resistor.
7. Check the Positive HV Plate for cracks around the metal plate and Epoxy



### Pressure Sensor Failure

#### Definition:

The Pressure sensor reads the pressure at the Ink Manifold, if the reading shows a short or is not giving a reading, this error/fault will be displayed.

#### Corrective Action:

1. Check the wires in the Pressure Transducer cable connector at the CPU board, (J13) and make sure they are all connected and not broken or loose.
2. Ensure the Pressure Transducer cable is tightened down on the Pressure Transducer completely.
3. Replace the Pressure Transducer & or Cable



Pressure Transducer cable connection at J13



Pressure Transducer





Pressure Transducer Cable

## Pressure Sensor Inaccurate

### Definition:

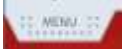





As the Pressure Transducer controls the system ink pressure needed throughout the Ink system, the starting pressure needs to be within +/- 1.0psi with the pump off. If outside of this starting pressure, then this error/fault will be displayed. Depending on the particular elevation the printer is sitting in or in some cases where the CPU board has received some kind of corrupt data, the CPU board may have an accidental "offset" and shows a pump off pressure outside of the +/-1.0psi. This can be verified by

pressing the [Menu]  button, then press the [Status]  button. Ensure the pump is off.

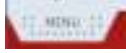
### Corrective Action:

Reset the CPU board Pressure by;

1. Tools Needed: Reset Jumper, part number (xxx-xxxx-xxx)
2. Switch off the power and unplug the power cable from the left side of the printer. Unplug the Pressure Transducer from the CPU board J13 and plug in the reset jumper plug.

3. Plug the power cable back into the power outlet on the left side of the printer. Turn on the power. Once the printer has booted up, then press the [Menu]  button and then press the [Service]  button.
4. Press the [Advance Service]  button. Type in the Advance Service Password and press the [Enter]  button on the keyboard.
5. Press the [Enter]  button 3 times, then type in the Advance Service command PRESSURE, then press [Enter]  on the keyboard.
6. “Command Executed” will be displayed (if entered correctly) and the pressure should be reset to 0.
7. Switch the power off and unplug the power cable from the left side of the printer, remove the reset jumper and reconnect the Pressure Transducer Cable. Reinstall the power cord and when the power is turned on again, the pressure should be at 0 (+/- 1.0).



Before Reset



After Reset

## Pump Pressure Error – PRESSURE HIGH

### Definition:

During operation or start up, if the pump pressure exceeds the limit, this error/fault will occur. This is basically when there is a clog in the ink system.

### Corrective Action:

1. Check Restrictor(s) for clogs. (See Section 6 sub-section Service Routines or removal/cleaning the restrictors)
2. Check Return Lines to Ink Tank for clogs.



3. Check Pressure Transducer (possibly an incorrect reading). See “Pressure Sensor Inaccurate”

### Pump Pressure Error – PRESSURE LOW

#### Definition:

This error/fault is caused when the pressure is continually falls below the set point (usually this is 40psi).

#### Corrective Action:

1. The Filter Module is clogged or dirty. Ensure that Filters have been changed within the timeframe specified in the maintenance chart.
2. Ink Pickup Tube is too close to Return Tubes. Ensure the Pickup Tube is set to the center of the ink tank and the return tubes are pointing away as seen in the picture below.

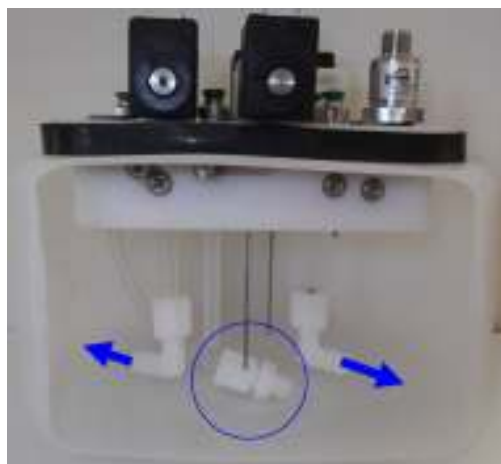

3. Ensure the Pickup Tube does not have anything blocking the input flow.

4. Check the fittings on the inlet side of pump for leaks. Leaks on the inlet side of the pump will pull in and will usually not leak in because they are on the vacuum side of the pump.

## Pump Motor Error

### Definition:

This would be displayed if the pump motor did not turn/start when the [Start]  button is pressed.

### Corrective Action:

1. Check the Fuses.
2. Check the Pump Cable.
3. Check the Pump Head for a seizure (if the motor operates).
4. Disconnect the Pump Head and perform a pump motor test (described below).

### Pump Motor Test:

- a. With the jet off remove the 3 screws that hold the pump to the motor and set aside. Remove the pump from the motor and let the pump set on top of the Ink Manifold. (**do not remove any tubing from the pump!**)

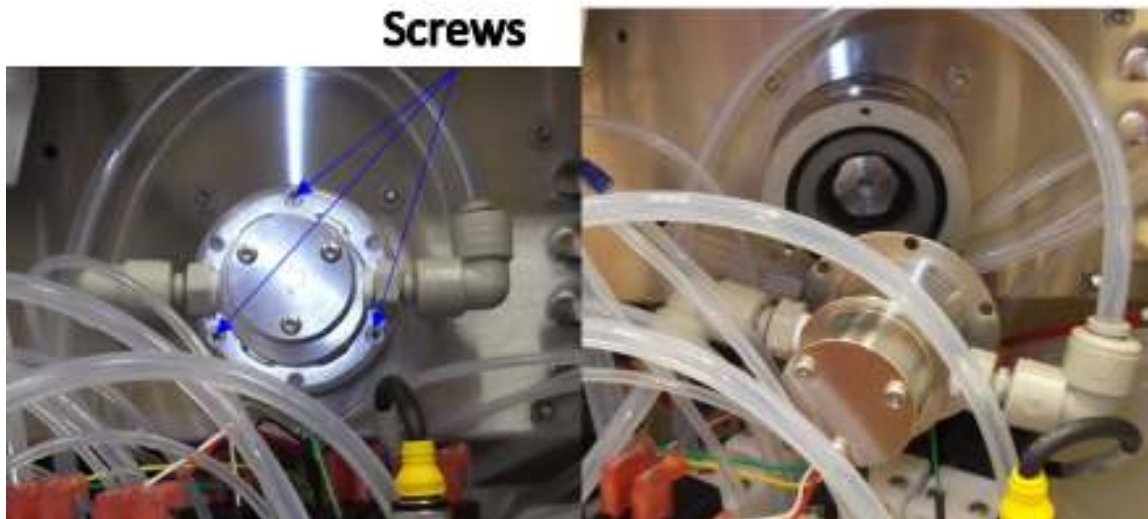





- b. Remove the 4 screws holding the motor to the inner wall leaving the cable plugged into the CPU board. You may need to cut the wire ties that hold the cable to the other group of cables.



- c. Set the motor on top of the printer cabinet.



- d. Press the [Menu]  button and then press [Service] .
- e. Press Run Pump  to check Pump circuitry.
- f. Using the marker, mark a line on the magnetic cup of the motor (see picture below) as a location mark at the 6 o'clock position, then press the [Increase]  button 1 time to start and rotate the motor at 5rps. If the motor turns, press [Decrease]  1 time to stop the motor and rotate the location mark to the next (7 o'clock in this case) position. Repeat this step until all 12 positions have been tested.

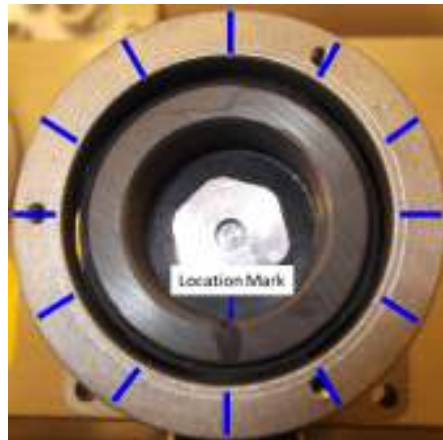

If any position fails to turn, this indicates either a defective motor drive on the CPU board. If all positions turn, this verifies that pump drivers are good.

## Viscosity High Error

### Definition:

The Citronix printer constantly monitors the ink viscosity by filling the viscometer with fresh ink from the Ink Tank at each fill. This fill process pushes a ball in the viscometer to the top of the tube and then the firmware counts the time (in seconds) that it takes for the ball to reach a sensor at the bottom of the tube. The viscosity must be maintained while the printer is running (ink stream) in order to print good quality prints. When the ink is high the printer firmware automatically adds Make-up to thin the ink down. All of the Citronix inks are solvent based and therefore tend to thicken up while running thru evaporation and printing. When the viscosity gets 1.5cP higher than the set point, this error/fault will be displayed.

### Corrective Action:

1. Ensure there is Makeup in the Makeup tank and the Pickup tube is fully seated into the quick connect filling (bottom of the Makeup manifold).
2. Ensure all the Fill caps are on tight.
3. Ensure the Ink and Makeup Manifolds are properly fitted and there is no cuts, gaps, or holes in the Manifold seals and that the manifold locking cams are engaged. This deduces evaporation.



4. Check the Makeup Add Valve for operation by using the [Test Valve]  screen in the Service Menu
5. Ensure the Makeup lines to and from the filter module are fully primed.

6. Verify the Viscometer Calibration Constant is the same as stated on the Calibration Label located inside the front door.

### **Viscosity Low Error**

#### **Definition:**

When the viscosity gets 1.5cP lower than the set point, this error/fault will be displayed.

#### **Corrective Action:**

1. Verify the Viscometer Calibration Constant is the same as stated on the Calibration Label located inside the front door.
2. Ensure the Makeup Add Valve is not stuck open. Also look for the Ink tank to be overfull while the Makeup tank is in a low status.

### **Viscometer Error**

#### **Definition:**

The printer firmware constantly monitors the location of the ball in the viscometer whenever the ink stream is on. If the firmware cannot location the position of the ball this error/fault will be displayed.

#### **Corrective Action:**

1. Verify the Viscometer Calibration Constant is the same as stated on the Calibration Label located inside the front door.
2. Check the operation of the Viscometer Valve.
3. Ensure the ball is moving by removing the Viscometer from the mounting bracket. Flush the ink out of it and tilt the viscometer back and forth while observing LED 9 on the CPU board. The LED will turn on when the ball is detected and off when the ball moves away from the ball detect sensor inside the viscometer housing.

### **Viscometer Not Calibrated**





#### **Definition:**

Each viscometer is calibrated by Citronix. A label is produced with the Viscometer Calibration Constant value and is attached to the inside of the front electronic door of the printer. This number is then entered into the printer firmware. If the CPU board is replaced or the number is erased in the firmware, this error/fault will occur.

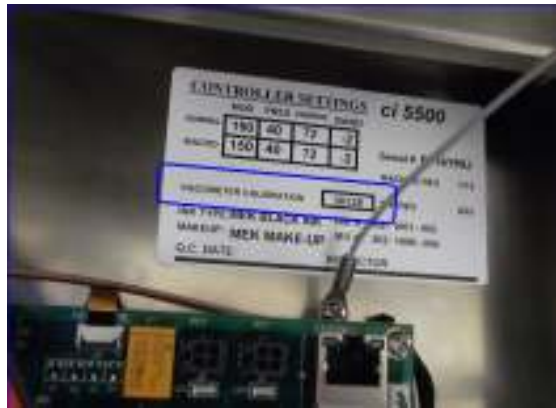
#### **Corrective Action:**

1. Look at the label on the inside of the front electronic door for the Viscometer Calibration Constant number.



2. Enter the number by pressing the [Menu]  button, then press [Service]  . Press the [Edit]  button to the right of Viscometer Cal Cnst and using the keypad enter the number, then press [Save]  . Then press the [Back]  button to return to the Main Menu.

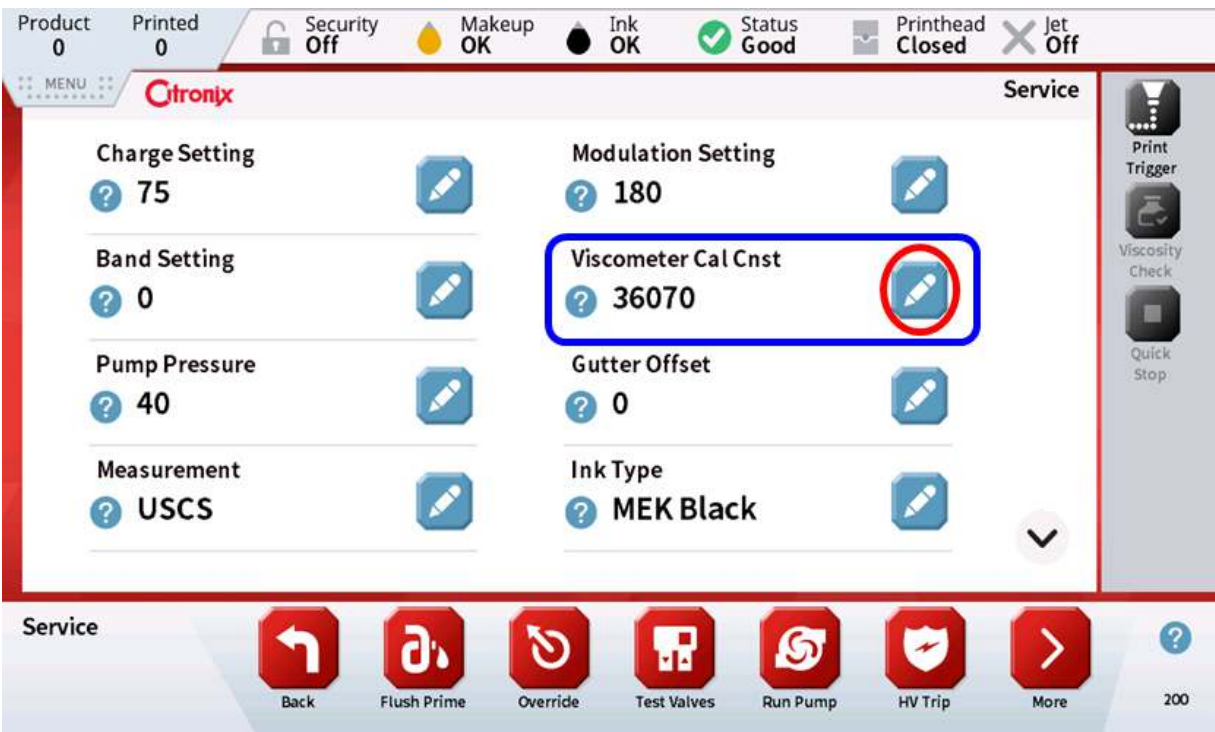

## High Pump Speed

### Definition:

The Citronix firmware controls/monitors the pump speed in RPS (Revolutions Per Second). If the Pressure Transducer does not read the pressure set in the software (example normal 40psi), the firmware will increase the pump speed until that pressure is met. When the pump speed exceeds 80

RPS, the error/fault will be displayed and the printer will automatically shutdown to attempt to prevent damage to the ink pump.

**Corrective Action:**

Check to ensure the ink pump is not blocked by;

1. Inspect the Ink Manifold to ensure the Pickup tube is fully inserted into the quick connect fitting on the underside of the Manifold and is not blocked.
2. Ensure ink is flowing into the pump by removing the output tube of the pump and place in a beaker. Run the pump manually.
3. Ensure ink is flowing out of the Filter Module by removing the pressure tube at the ink manifold (output tube from the filter module), placing it in a beaker and running the pump manually.

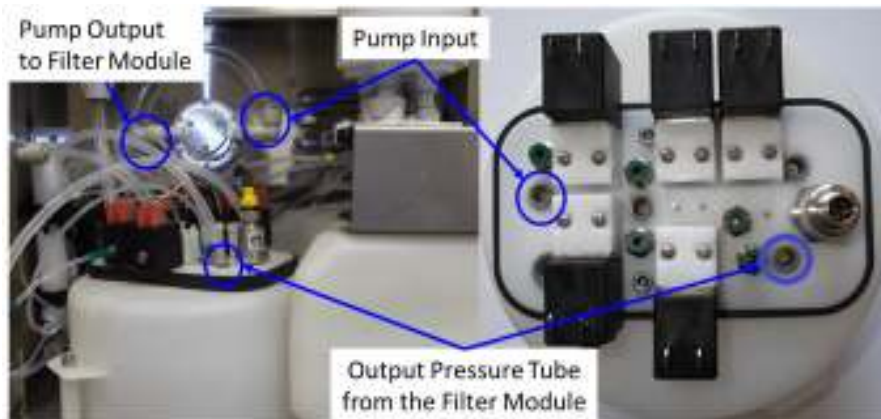

**Low Pump Speed**

**Definition:**

When the pump speed continually drops below 15 RPS, the error/fault will be displayed and the printer will automatically shutdown to attempt to prevent damage to the ink system.

**Corrective Action:**

1. Remove and clean the restrictor in the Ink Manifold they could be clogged. (see page xx-xx for the removal process)
2. Return Tube are pointed at the Ink Pickup Tube. See “Pump Pressure Error – PRESSURE LOW” above (page 6-18)

**No Tach Error**

**Definition:**

The firmware monitors the 3 drive signals from the pump motor; when no signal is received this error/fault will be displayed. This error deals with the pump motor and cable.

**Corrective Action:**

1. Check the pump motor is plugged in correctly on each end.
2. Replace the motor cable
3. Replace the motor

### **Tach 1 Error**

#### **Definition:**

As mentioned above, there are 3 motor drive signals inside the pump motor. If 1 drive is not working, this will display this error/fault.

#### **Corrective Action:**

1. Check the pump motor is plugged in correctly on each end.
2. Replace the motor cable
3. Replace the motor

### **Tach 2 Error**

#### **Definition:**

As mentioned above, there are 3 motor drive signals inside the pump motor. If 1 drive is not working, this will display this error/fault.

#### **Corrective Action:**

1. Check the pump motor is plugged in correctly on each end.
2. Replace the motor cable
3. Replace the motor

### **Tach 3 Error**

#### **Definition:**

As mentioned above, there are 3 motor drive signals inside the pump motor. If 1 drive is not working, this will display this error/fault.

#### **Corrective Action:**

1. Check the pump motor is plugged in correctly on each end.
2. Replace the motor cable
3. Replace the motor



### **Printhead Temperature Fault – TOO HOT**

#### **Definition:**

The Printhead contains a temperature sensor to ensure the flammable fluid temperature ignition point is not exceeded. Set well below the ignition point, if the temperature at the Printhead exceeds 60° C, the

printer will shut down automatically and this error/fault will be displayed. The sensor is part of the Drop Generator and is non-repairable.

**Corrective Action:**

1. Ensure the ambient Temperature is not above 60°C. if so, remove the printer to a cooler area.
2. Press the [Menu]  button and then [Status]  to view the Nozzle Temperature. Ensure the temperature is above 60° C.
3. Inspect the wires on the printhead connector J3 pins 3 & 4 on the CPU board. Ensure they are properly connected and there is no break in the wires.

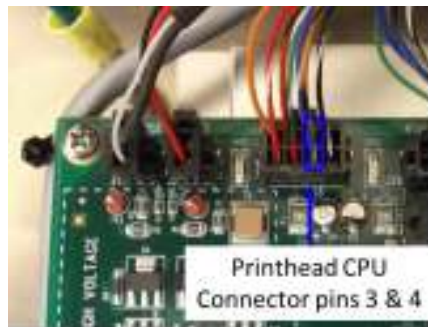

4. Check the sensor connection in the top compartment of the printhead for a good connection.

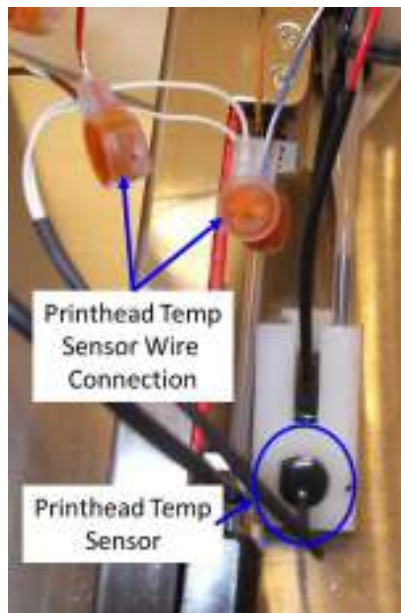

5. Disconnect the wires at the printhead and unplug the J3 connector and use a Multimeter, check the wires for continuity (no breaks).
6. Replace the Drop Generator Assembly.

**Printhead Temperature Fault – SENSOR SHORTED**

**Definition:**

The temperature signal at the Printhead has been shorted. The printer will shut down automatically and this error/fault will be displayed. The sensor is part of the Drop Generator and is non-repairable.

**Corrective Action:**

1. See the corrective action 2 thru 6 for “Printhead Temperature Fault – TOO HOT”

**Printhead Temperature Fault – SENSOR OPEN**

**Definition:**

The temperature signal at the printhead has an electrical open. The printer will shut down automatically and this error/fault will be displayed. The sensor is part of the Drop Generator and is non-repairable.

**Corrective Action:**

1. See the corrective action 2 thru 6 for “Printhead Temperature Fault – TOO HOT”

**Temperature Fault – CPU TEMP TOO HOT**

**Definition:**

The Citronix ci5000 series printer cabinet has a temperature sensor that continually monitors the cabinet temperature to ensure the proper operating temperature is being maintained and removes solvent fumes from building up in the cabinet. This temperature will be (5-10°C) from the ambient temperature due to the heat from the electronics. When the cabinet temperature reaches 70°C this error/fault will be displayed. The CPU board temperature sensor is not field repairable.

The temperature can be view by pressing the [Menu]  button, then press [Status] .

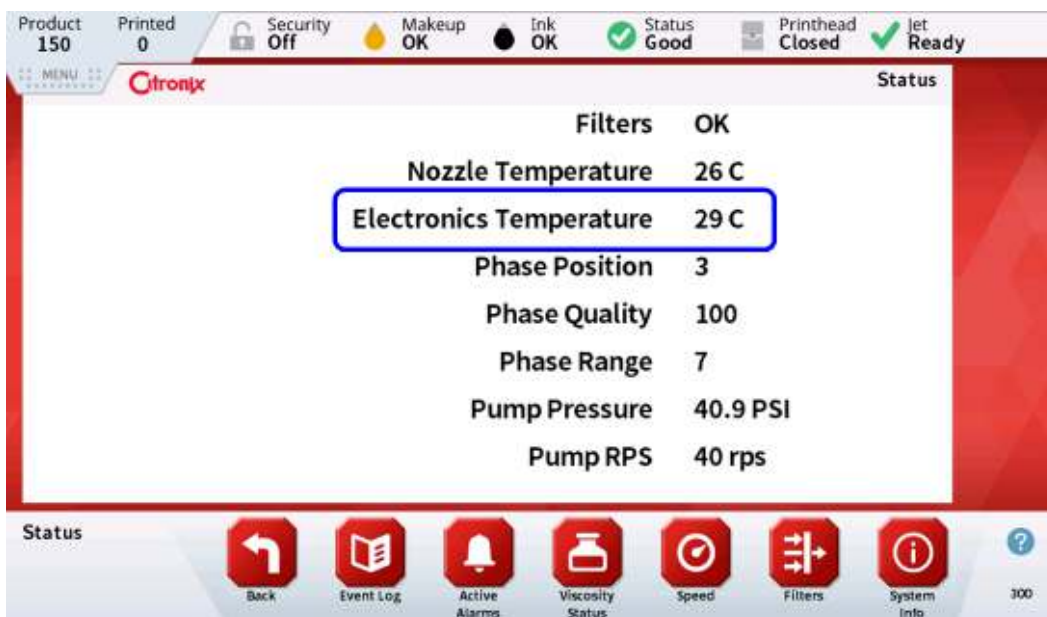

This sensor is located on the CPU board (see the picture below).



**Corrective Action:**

1. Ensure the fan is operating.
2. Ensure the Air filter is not clogged (replace if needed). For replacement procedure see Section 6 Sub-section “Replace/Clean Air Filter”
3. Ensure the Sensor is not laying on any board components. The sensor needs to be freestanding as shown in the picture above.

**Temperature Fault – CPU TEMP SENSOR SHORTED**

**Definition:**

The temperature signal on the CPU board has been shorted. The printer will shut down automatically and this error/fault will be displayed. The sensor is part of the CPU board and is non-field repairable.

**Corrective Action:**

Replace the CPU board (see page [xx.xx](#) CPU Board replacement procedure)

**Temperature Fault – CPU TEMP SENSOR OPEN**

**Definition:**

The temperature signal on the CPU board has an electronic open. The printer will shut down automatically and this error/fault will be displayed. The sensor is part of the CPU board and is non-field repairable.

**Corrective Action:**

Replace the CPU board (see page [xx.xx](#) CPU Board replacement procedure)

**Ink Reservoir Empty**

## Definition:

The ci5000 series printers constantly monitor fluid levels in the Ink & Make-up tanks. These levels are maintained to a volume that allows fast and easy viscosity control during normal operation. This is done using 3 level rods (low, high, and a ground) that are underneath the Ink Manifold. The ink is detected between the ground and high or low level rod. When the level in the ink tank drops below the low level rod an “Ink Reservoir Low Add Ink” warning will be displayed. If after 8 running hours the level has not risen above this Low Level rod, the printer will shut the printer down to ensure the ink level does not drop below the Ink Pickup tube. If this happens, damage can happen to the Ink Pump.

## Corrective Action:

1. Add Ink (see Section 3 Sub-section “Add Ink and Make-up”)
2. If not low
  - a. Check that the level rod wires are connected to the proper level rods. (See the picture below Pic 1)
  - b. Ensure the power is off, disconnect the Ink Level rod wires from the CPU board (J12) and using a multimeter check continuity of all 3 of the Ink level rod wires from the Manifold connector to the CPU board connector for an open or break in the wire. (See Picture below Pic 2)
  - c. Replace the Level Rod Wires harness (see page [xx.xx](#) Level Rod Wire harness replacement procedure)
  - d. Replace the CPU Board (see page [xx.xx](#) CPU Board replacement procedure)



*Pic 1*



*Pic 2*

## **Makeup Reservoir Empty**

### **Definition:**

The ci5000 series printers constantly monitor fluid levels in the Ink & Make-up tanks. The level in the Make-up tank is used to maintain a proper level to ensure enough Make-up to control the viscosity in the Ink tank during normal operation. This is done using 3 level rods (low, high, and a ground) that are underneath the Make-up Manifold. The Make-up is detected between the ground and high or low level rod. When the level in the ink tank drops below the low level rod an “Add Make-up” warning will be displayed. If after 8 running hours the level has not risen above this Low Level rod, the printer will shut the printer down to ensure the ink viscosity does not get out of control and rise too high causing poor print quality or damage to the Ink Pump or other component failures or clogs.

### **Corrective Action:**

1. Add Make-up (see Section 3 Sub-section “Add Ink and Make-up” )
2. If not low
  - a. Check that the level rod wires are connected to the proper level rods. (See the picture below Pic 1 with Filter Module removed)
  - b. Ensure the power is off, disconnect the Make-up Level rod wires from the CPU board (J11) and using a multimeter check continuity of all 3 of the Make-up level rod wires from the Manifold connector to the CPU board connector for an open or break in the wire. (See Picture below Pic 2)
  - c. Replace the Level Rod Wires harness (see page [xx.xx](#) Level Rod Wire harness replacement procedure)
  - d. Replace the CPU Board (see page [xx.xx](#) CPU Board replacement procedure)



*Pic 3*

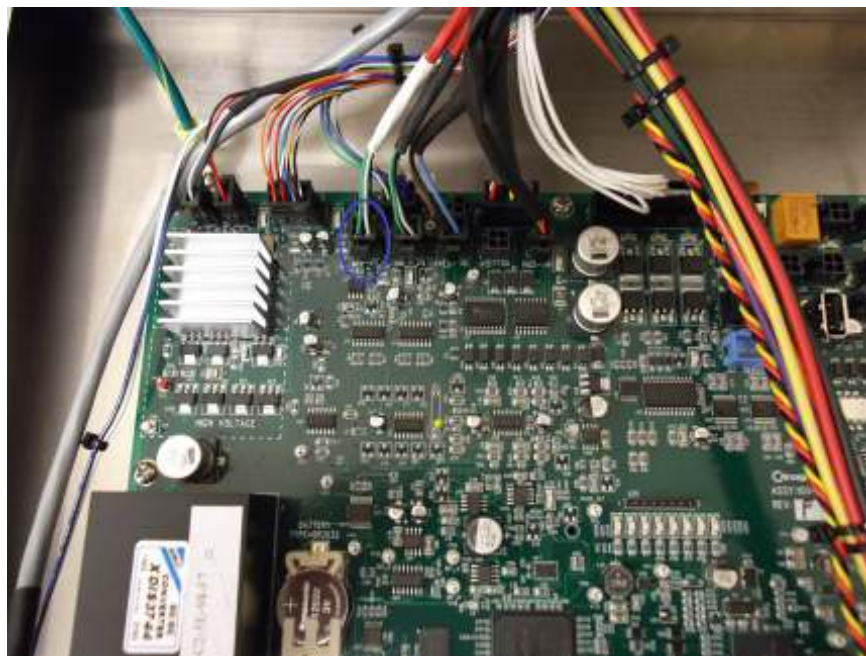

*Pic 4*

**Definition:**

When the Ink level in the ink tank drops below the low level rod (500ml) this “Ink Reservoir Low Add Ink” warning will be displayed as shown below.

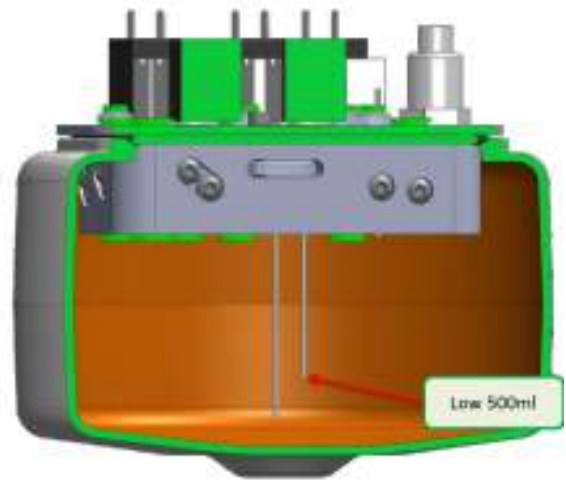
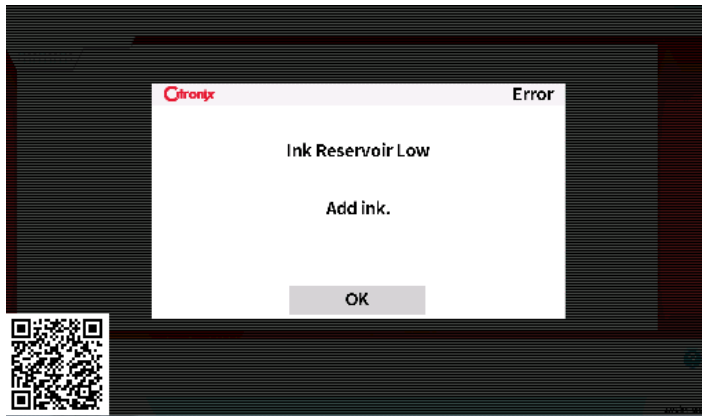

**Corrective Action:**

Add Ink (see Section 3 Sub-section “Add Ink and Make-up”)

**Ink Probe Shorted**

**Definition:**

This error will occur when the CPU board senses a short on any of the Ink level sensing circuit.

**Corrective Action:**

1. Remove the Ink Manifold from the Ink tank and ensure the level rods are not touching each other.
2. Remove the Level Rod Wires from the rod on top of the Ink Manifold. Then unplug the level rod cable from the CPU board J12connector. Ohm each wire for continuity. If a short is found replace the cable assembly.
3. Replace the CPU board. (see the CPU Replacement procedure earlier in this manual)

**Makeup Reservoir Full**

**Definition:**

The Make-up Tank level is monitored continuously with 3 level rods to maintain the optimum level of Make-up. When the level gets to the “High” level sensing rod, there will be ~2200ml of Make-up in the tank. This will send the “Make-up Reservoir Full” error/fault and will shut the printer down. This is to prevent Make-up from spilling out causing a hazardous condition. The normal operating level is between 1500 to 374ml. See Fig 1 below.

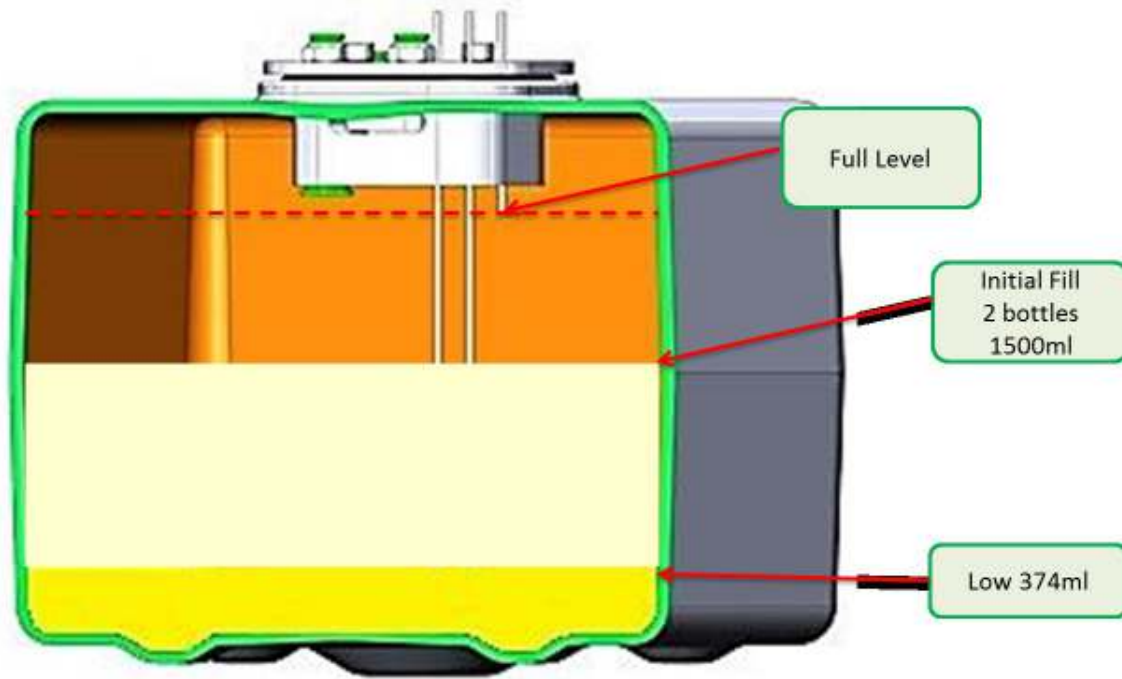

Fig 1

**Corrective Action:**

1. Inspect the Make-up level thru the tank and ensure the level is in fact high.
  - a. If not high
    - i. check the level rod wires for continuity back to the CPU board...if good
    - ii. replace the CPU board
2. If the level is high, remove Make-up by;
  - a. Turn the power off using the appropriate shutdown routine.
  - b. Remove the Ink System housing cover by using a 5/32" Allen and turning ¼ turn clockwise in the lock, then lift the cover up and off.
  - c. Remove the Service Module base by removing the securing screw holding the bracket to the back wall of the Ink System and set the assembly aside.
  - d. Remove the Make-up fill port and tube by first removing the 3 screws securing the port to the cabinet. Then pressing the top of the quick disconnect fitting located on the top of the Manifold (shown in Pic 1) and pulling the tube up and out of the top of the Makeup Manifold.
  - e. Using a 5/32" Allen wrench, turn the two manifold securing cams ¼ turn counterclockwise.
  - f. While lifting the Manifold out of the tank, carefully remove the tank out of the Ink compartment of the cabinet. Use absorbent cloths to collect excess Makeup from the pickup tube.
  - g. Remove Makeup from the Make-up tank until the level is equal to the midlevel seam of the tank and dispose of in accordance with local regulations.
  - h. Replace Makeup tank by reversing the above steps.
  - i. Refit the Ink System housing cover and restart the printer.

## Makeup Reservoir Low

### Definition:

This warning/fault will occur when the level of Make-up in the Make-up tank drops below 374ml and is no longer touching the “Low” Level rod.

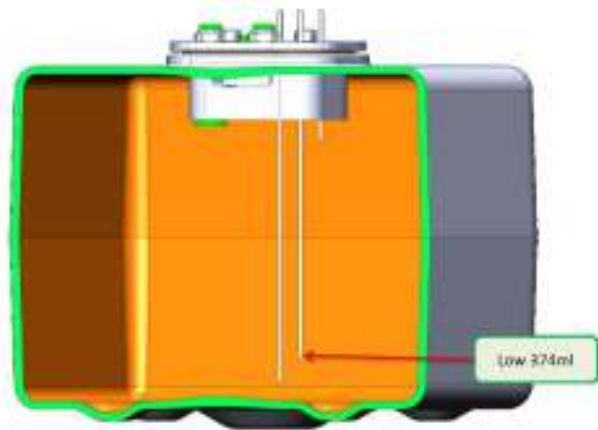

### Corrective Action:

Add Make-up (see Section 3 Sub-section “Add Ink and Make-up”)

## Makeup Probe Shorted

### Definition:

This error will occur when the CPU board senses a short on any of the Make-Up level sensing circuit.

### Corrective Action:

1. Remove the Make-Up Manifold from the Make-Up tank and ensure the level rods are not touching each other.
2. Remove the Level Rod Wires from the rod on top of the Make-Up Manifold. Then unplug the level rod cable from the CPU board J11 connector. Ohm each wire for continuity. If a short is found replace the cable assembly.
3. Replace the CPU board. (see the CPU Replacement procedure earlier in this manual)

## Filter Service Required

### Definition:

The ci5000 series printers introduce ciEasyServ: a quick, easy, no mess/no fuss, tool free service module. This Service Module (filter assembly) filters all ink and Make-up fluids throughout the printer while the pump is running. This must be changed out at a set number of run hours to provide clean fluids

free from dirt and debris. This varies depending on the environment. When this time has expired, this error/fault will be displayed.

**Corrective Action:**



For a detailed procedure see Section 6 Subsection “Service Module Replacement”.

**Printing Too Fast**

**Definition:**

The “Printing Too Fast” warning/fault indicates that the print frequency is greater than the maximum print frequency. This is when the shaft encoder is over-clocking indicating that either the Width setting is too small and should be increased, Print Quality setting is too high, the Bold setting is too high, or the line speed is too fast and should be reduced to print consistently.

**Corrective Action:**

Monitor the [Speed]  screen (found in the [Status]  window) while the line is running. Ensure the “Print Frequency” has a smaller value than the “Max Print Frequency”. This can be done by adjusting (up or down) the Print Quality, Width, Gap, and Bold values in the [Print Adjust]  screen. After each adjustment always go back to the [Speed] screen to review the changes. This will be different for each size of message.

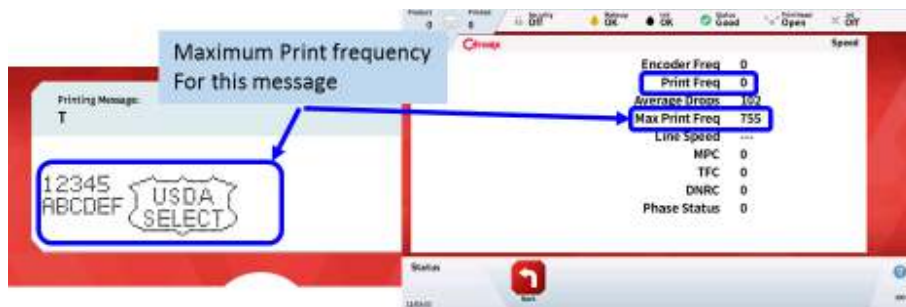

For example:

A message using a 16 pixel font may need a “Print Quality” setting of 280 where a message using a 25 pixel would use 120 “Print Quality” setting when both use a width of 10.

For further explanations See section “Print Adjust Parameters”.

**Counter Completed**

**Definition:**

This warning will appear when the “Counter Wrap” option is not enabled and the counter has reached its upper limit.

**Corrective Action:**

If the counter is not meant to start over once the upper limit has been reached, then there is no corrective action necessary. This is just an indicator to reset the counters in the message manually.

If the counter is meant to start over once the upper limit has been reached, then the following are steps described in Section 3 of this manual under *Message Fields, Autocodes, Counters* to find the “Counter Wrap” option and change/set it.

## Login Failure

### Definition:

This warning/error indicates either the wrong User Name or Password was used while trying to log into the security of the printer.



### Corrective Action:

Contact your supervisor for the correct User Name and Password information and try logging on again

**NOTE: Both User Names and Passwords are case sensitive!**

## Not Logged In, wrong user name or password

### Definition:

When Security is enabled (turned on), users are required to log in. this is done at power on Or by accessing the [Security]  screen from the [Menu Bar Tab] . If the wrong username or password is entered this Error/fault will be displayed.

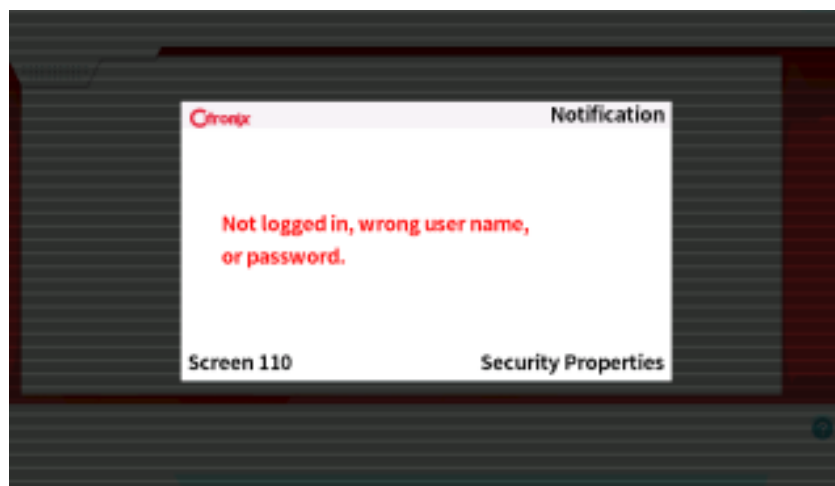

### Corrective Action:

Consult your Supervisor for the proper User Name and Password and try logging on again.

## Restore In Progress

**Definition:**

This warning will appear while a “Backup” file is being restored/downloaded to the printer.

**Corrective Action:**

There is no corrective action to be taken. This screen will disappear after the Restore is complete.

**Ink Stir In Progress****Definition:**

In a printer using a Pigmented or Heavy Pigmented ink, the firmware automatically stirs the ink every hour to keep the pigment suspended in the ink when the jet is not on. When this “stir” function is in process this warning/indication will be displayed on the main screen. This warning/indication screen can be hidden by pressing the screen.

**Corrective Action:**

There is no corrective action needed as this is a normal function of a Pigmented or Heavy Pigmented printer.

**Flush Stop In Progress****Definition:**

When the Jet is being turned off, the printer automatically performs a flush of the printhead (nozzle & Gutter). During this process if

**Corrective Action:**

No Action required

**Firmware Download Below Minute****Definition:**

This Error/Warning will be displayed when trying to downgrade the firmware below what the software deems safe.

**Corrective Action:**

This is not recommended as this can cause the CPU board to lock up and be non-functional. Consult the Technical Support Specialist at Citronix before attempting this. If the CPU board becomes locked up, it may need to be returned to Citronix for a complete memory wipe and reprogrammed.

**Printhead Temperature Low****Definition:**

This Error/Warning will be displayed when the temperature drops below the recommended operating temperature of 32°F (0°C).

**Corrective Action:**

Move the Printhead to an environment that is above this temperature.

**Flush Stop Not Completed**

**Definition:**

This Error/Warning will be displayed anytime the jet shuts off without letting the stop flush complete, usually when the power was interrupted or turned off.

**Corrective Action:**

Backflush the nozzle, clean and dry the printhead, and restart the jet.

If the printer is not going to be used, perform a proper shutdown by pressing the power button and press [OK] to allow the jet to flush and then power off automatically OR press the [Stop] button and wait until the jet indicator states "Off", then turn off the power.

**Power Off Before Jet Stop**

**Definition:**

If at any time the power is cut off or removed from the printer before a proper shutdown is completed, this error/fault will be displayed.

**Corrective Action**

Perform a Backflush of the nozzle and start the jet (see Section 6 Sub-section "Backflush Routine"). If the printer is not needed, press the Stop  button and allow the printer to perform a complete shutdown. Then power can be turned off the printer (unless the printer is a Pigment or Heavy Pigment machine, these printers should not have the power turned off). You can also (while the jet is running) press the power button. The printer firmware will prompt you to confirm (by pressing OK) that you want to shut off the jet. Once this is acknowledged the printer will automatically perform a flush and then turn the power off.



## Service Routines

### Backup & Restore

#### Backup

Copies of the entire printer configuration, messages, graphics, and system parameters are copied and stored to restore the original printer settings. This can be done using the On Board SD card or a USB (seen below).

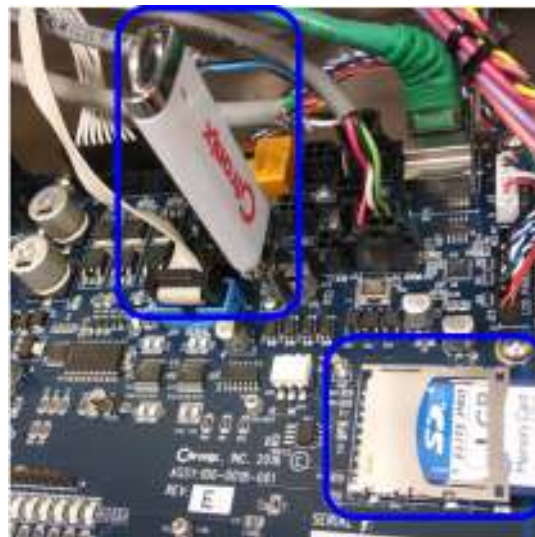

The backup file can be used to “CLONE” or “COPY” printers. This is useful when needing to use the same messages in multiple printers in a production environment without having to type/create the same messages multiple times. If the Backup file is used onto a different printer/CPU board, then only the message, graphic and message parameters will be transferred over to the “CLONE” or “COPY”.

The Backup file can also be used to restore the original printer back to a previous working status. This is useful if the CPU board needs to be erased or changed. The backup file can be saved via the Ethernet, SD or USB.

### Backup Ethernet:

If the printer is connected to the same LAN as your computer, you can open a web browser and type in the IP address of the printer and press Enter. Below will be the window that will open.

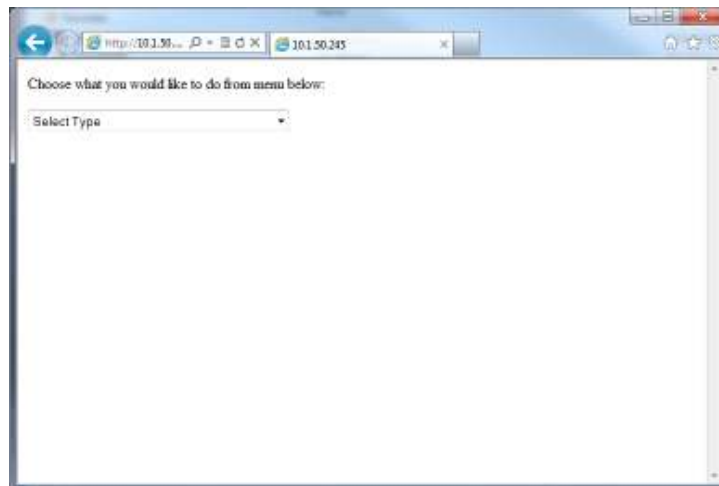

Click on the drop down box and select Backup Printer:

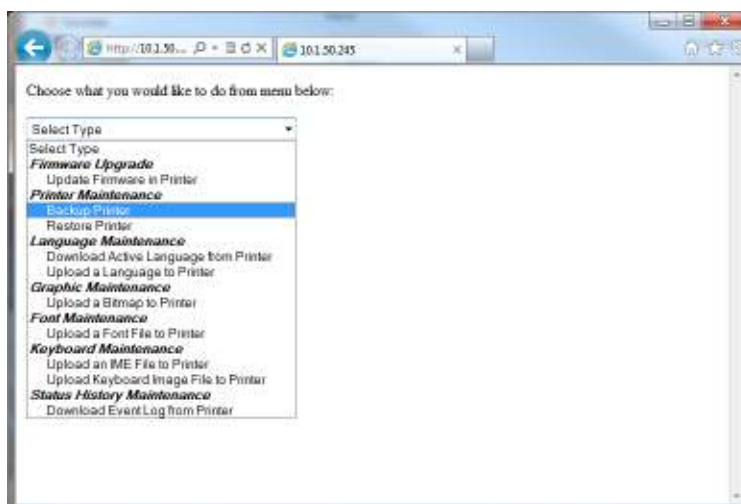

1. A separate window will open and will display the Backup file data as shown below.

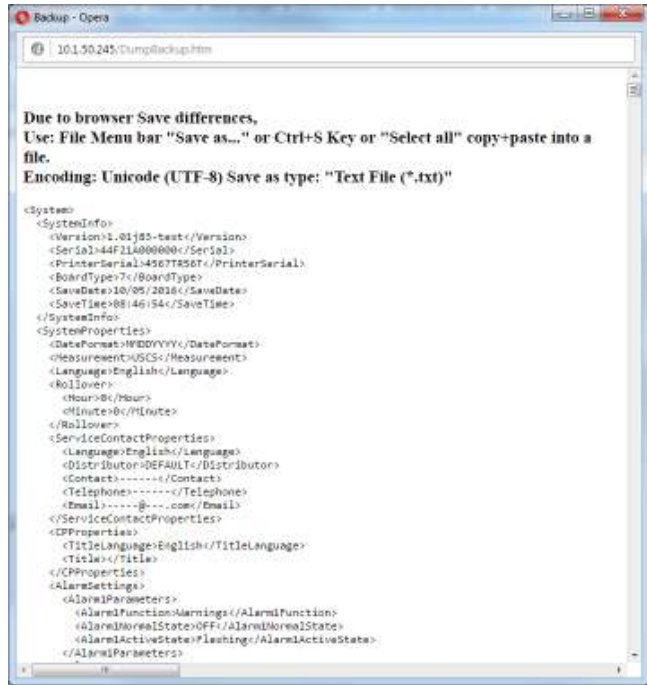

2. Due to the difference in the way browsers save, make sure to use: Ctrl+S Key or "Select all" then copy and paste into a file into "Notepad". The file must be saved with Save as type: "Text File (\*.txt)" file Encoding: Unicode (UTF-8).

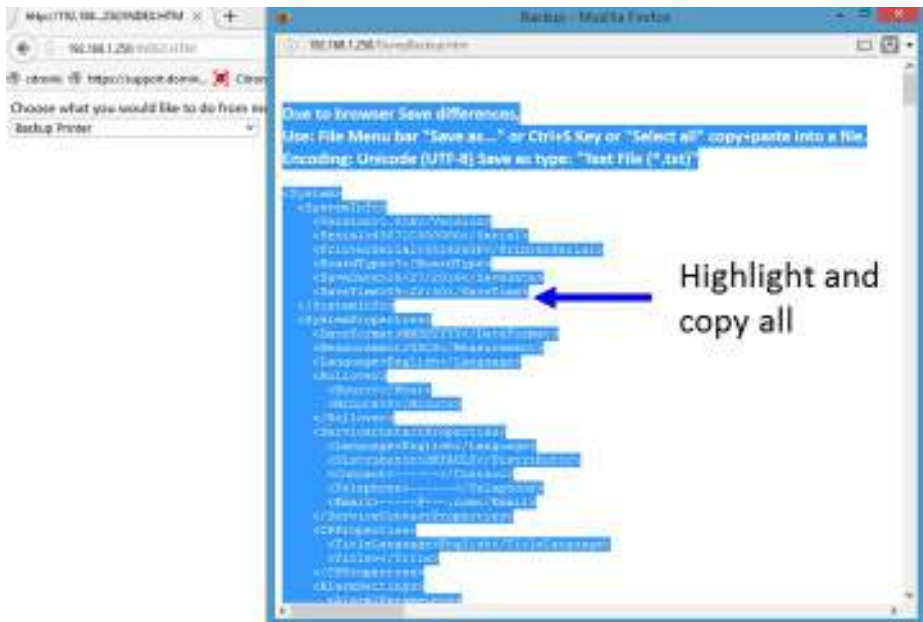

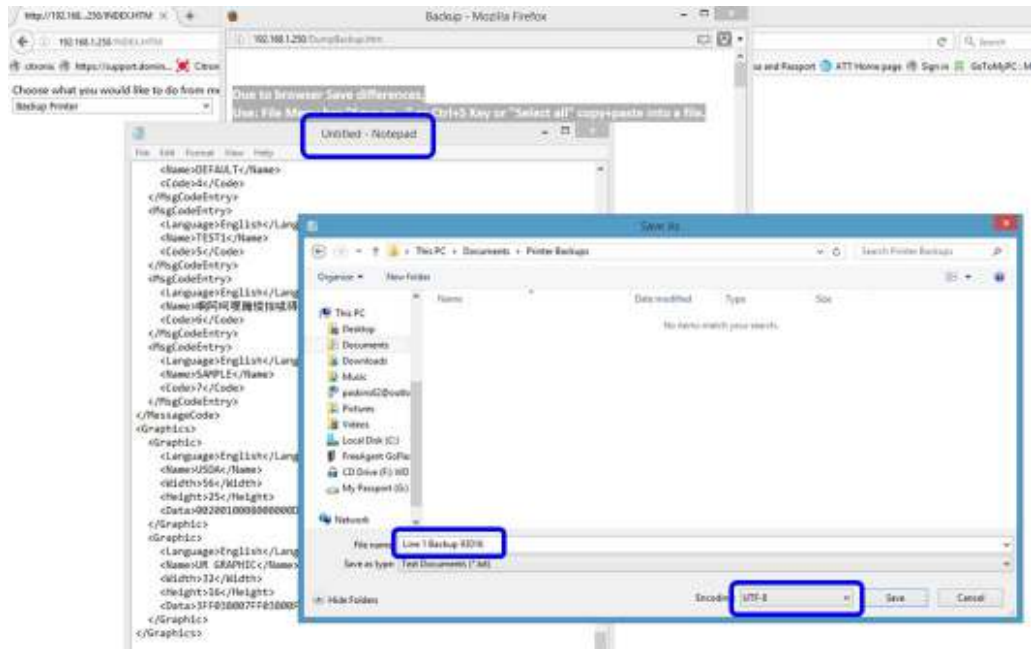

**Backup with USB or SD:**

Ensure the Power is off, then Insert the SD or USB into their respective ports, and then turn the power on.

On the [Menu Tab] select the [Properties] button.

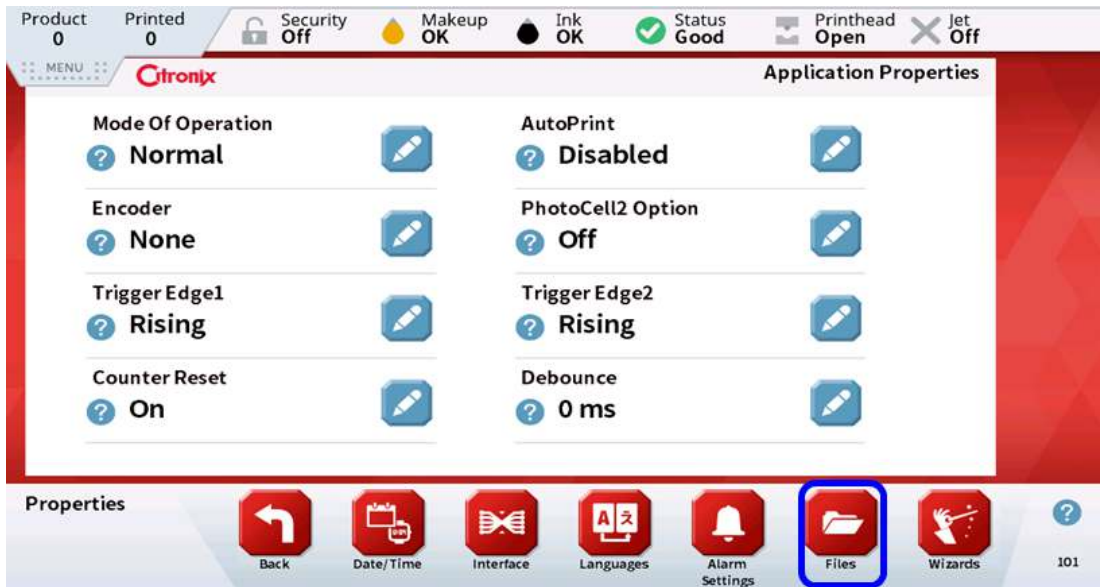

Select the [Files] icon in the Navigation Tool Bar. Press to highlight the device you want to use to save the Backup file. The example below shows the SD card is being used. The USB will show “Not Available” if one is not inserted into the USB Port on the CPU board. This indicates which device is being accessed.

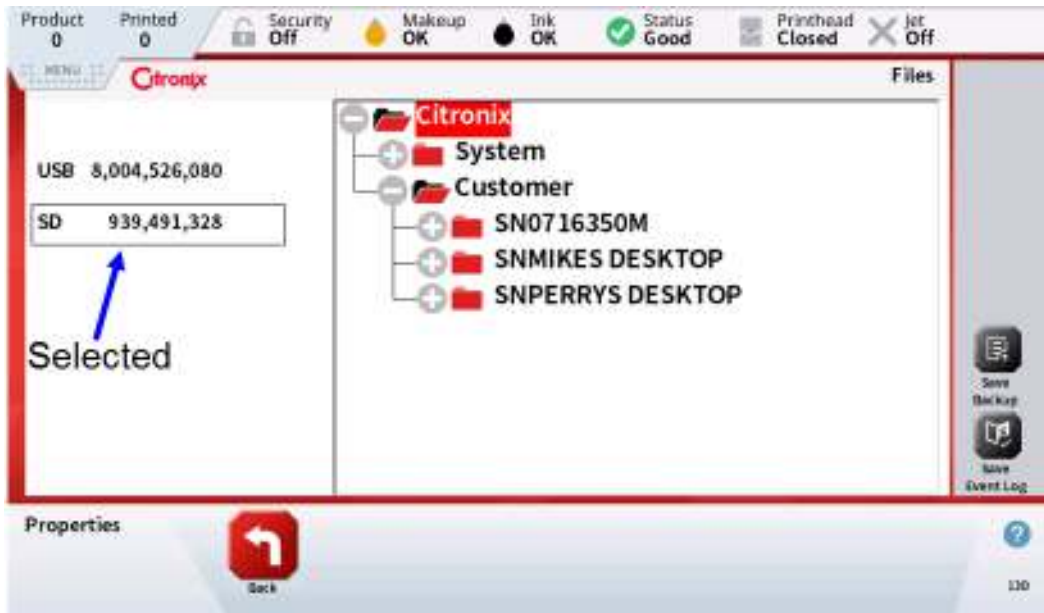

Press the [Save Backup]  button on the Functional Toolbar:

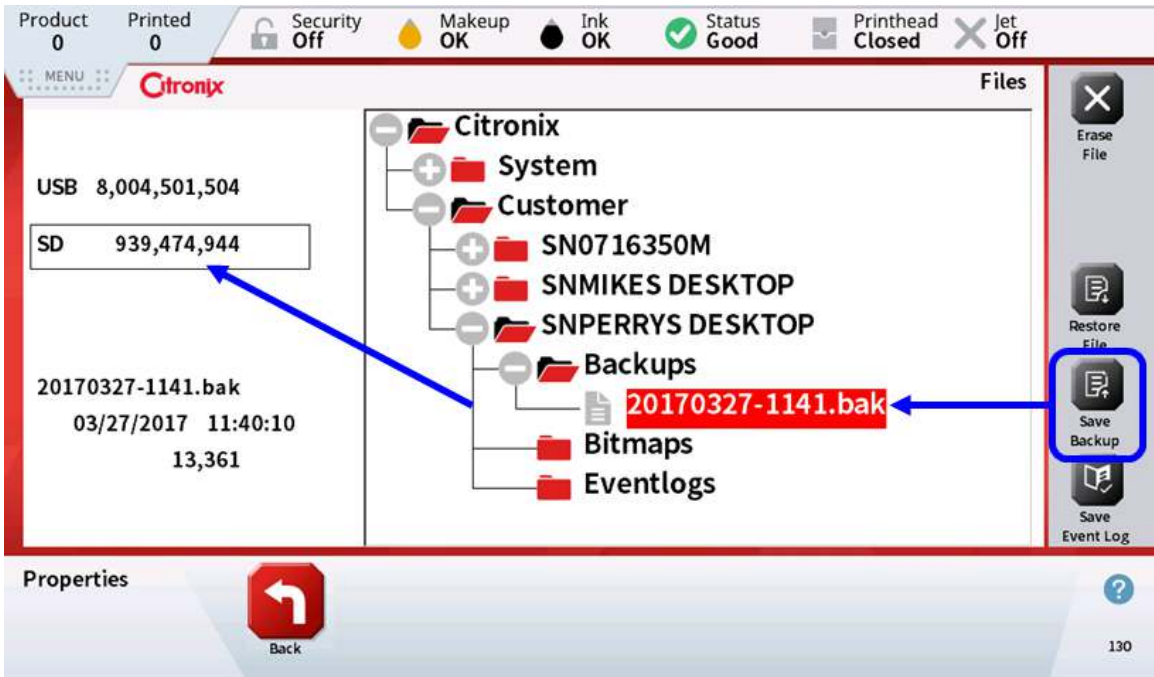

The backup file will be saved with a date and time.



***NOTE:*** Multiple Backup files can be saved to be used later.

***NOTE:*** DO NOT INSERT OR REMOVE THE SD CARD WHILE THE PRINTER IS ON. POWER MUST BE TURNED OFF!!

Once the power is off, the SD card can be removed and the files can be restored on another printer OR the card (all of the files) can be saved onto a PC.

The same procedure described above is used if selecting the USB.

### Restore Ethernet:

If the printer is connected to the same LAN as your computer, you can open a web browser and type in the IP address of the printer.

Click on the drop down box and select Restore Printer:

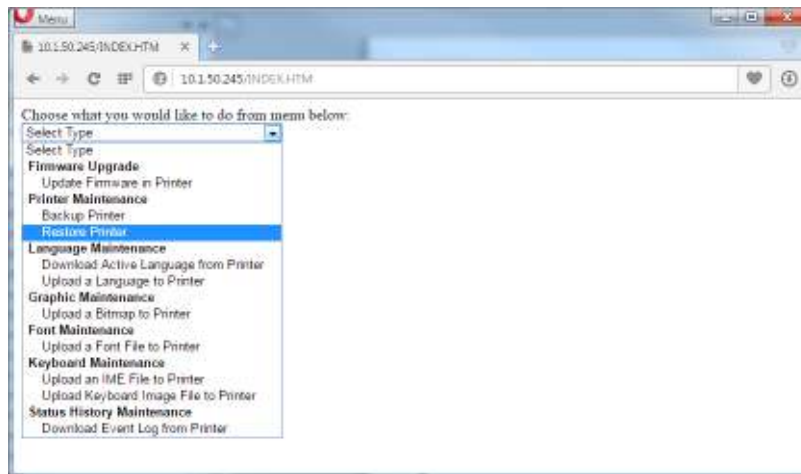

Click on Choose file and select a backup file from windows explorer window:

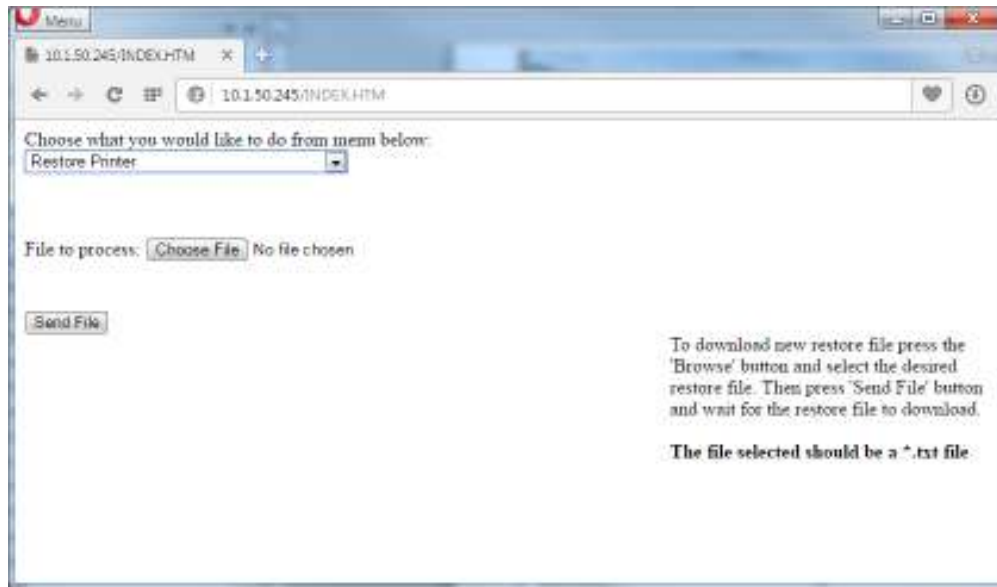

Press Send File.

### Restore from USB or SD Card:

Ensure the Power is off, then Insert the SD or USB into their respective ports, and then turn the power on.

On the [Menu Tab]  select the [Properties]  button, then select [Files] .



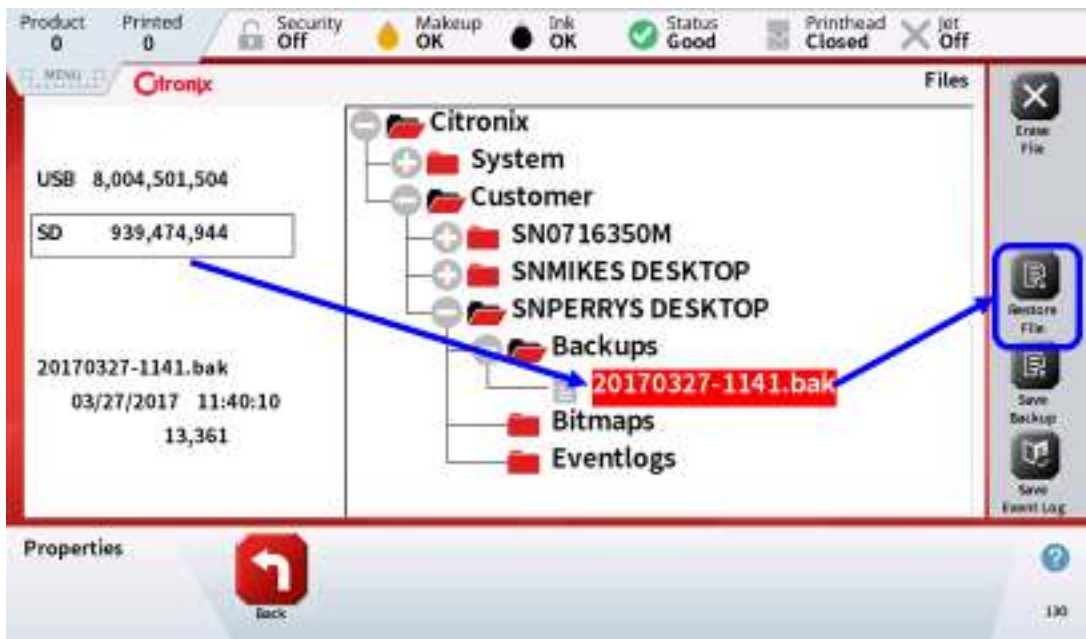

Press and highlight the device to be used (if both are installed). Touch the + symbol left of **Backups** to reveal the list of backup files. Touch to highlight the file to be used and press the [Restore File]  button.



## Firmware Updating

Updating the firmware is made easy by using the USB. The USB can be removed and installed while the power is on.

First insert the USB into the CPU board. Allow 20 seconds for the printer to recognize and download the file structure onto the USB. Then press the [Menu Tab]  select the [Properties]  button, then press the [Files]  button in the Navigation Tool Bar. Press the USB Icon on the left of the screen. If this the first time the USB is used, the printer will automatically install the File Structure onto the USB.

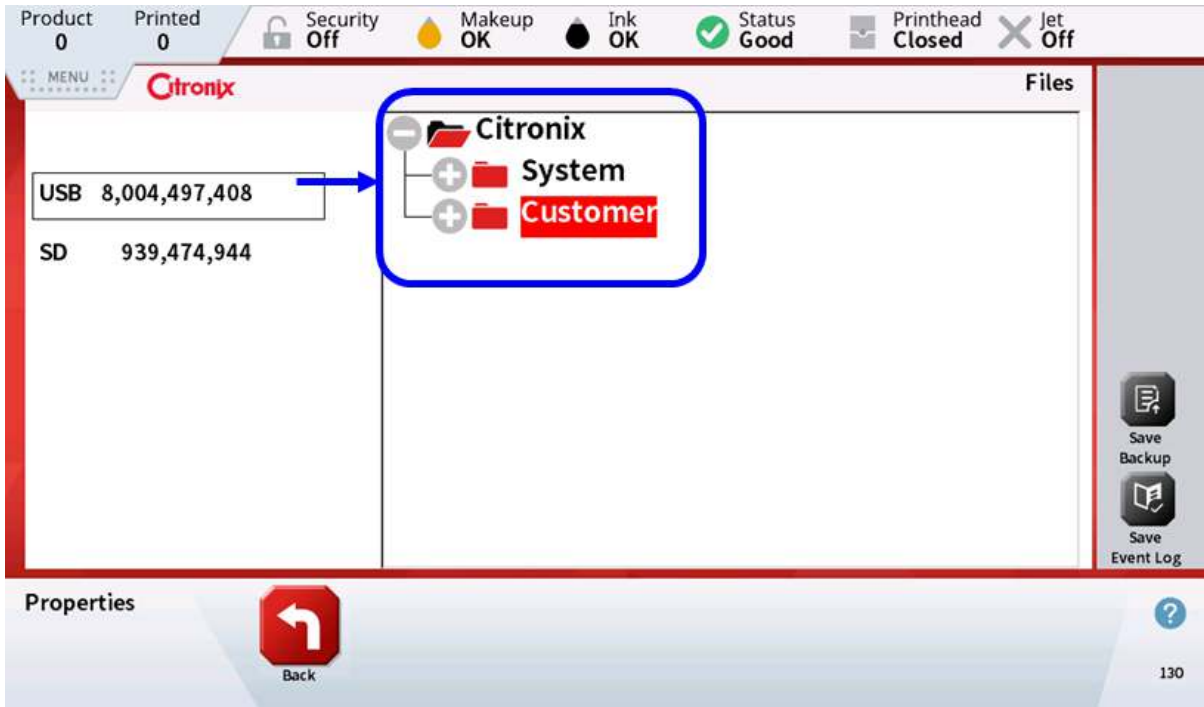

Now the USB can be removed and plugged into a computer to install the Firmware.

**Note:** *The new firmware must be loaded into the following file on the USB (Citronix/System/Firmware). Placing it in any other file or location will not be recognized by the printer.*

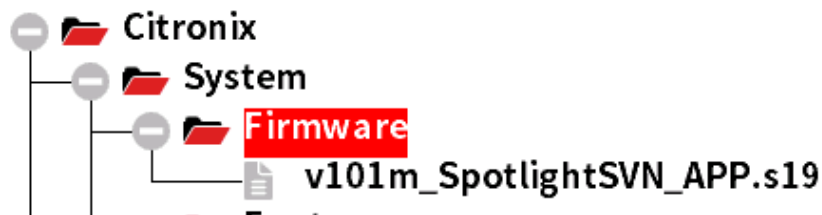

### Updating the firmware:

Once the USB is installed and the File is viewed on the screen (as seen below). Highlight the firmware and press the [Install Firmware] button in the Function Tool Bar on the right side of the screen.

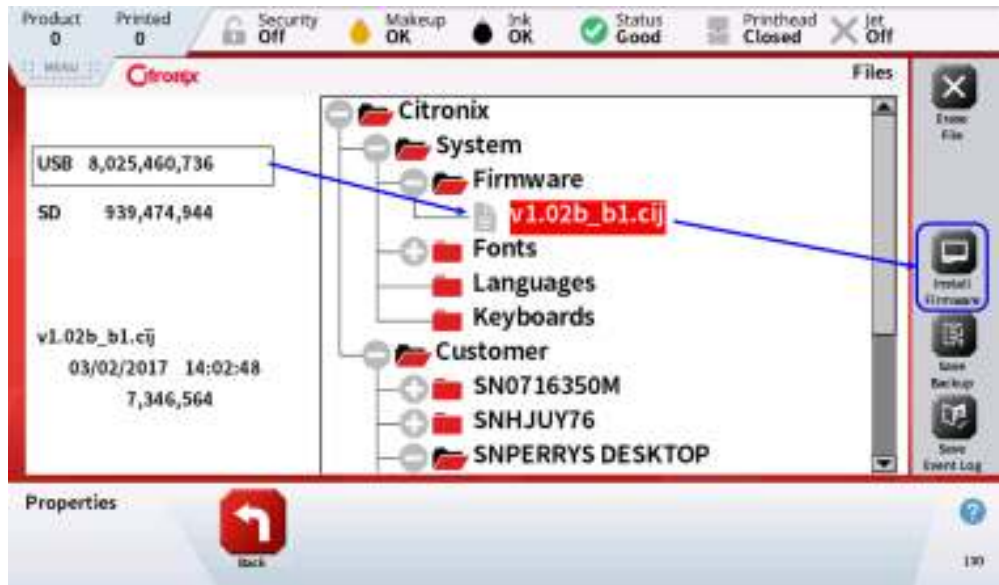

The following screen will open to confirm the updating of the firmware. Pressing [OK] will begin the installation process.

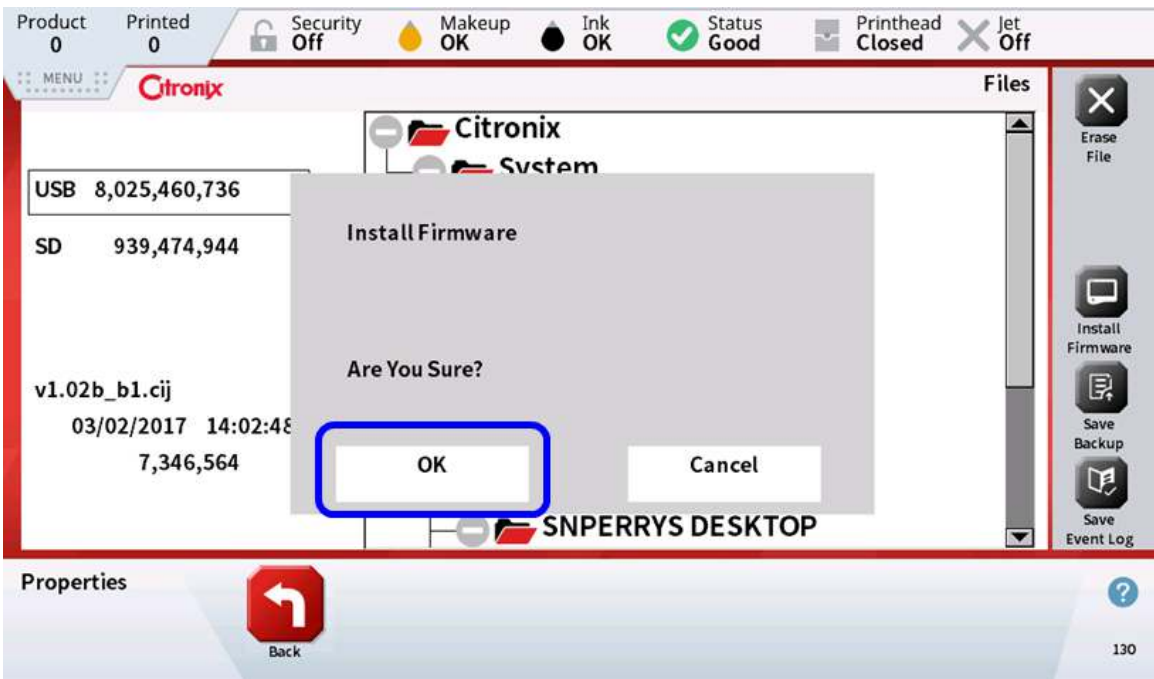

The following screen will be displayed while the firmware is being updated. Once this process is complete, the printer will reboot. After the Printer has fully rebooted, it can be used normally.

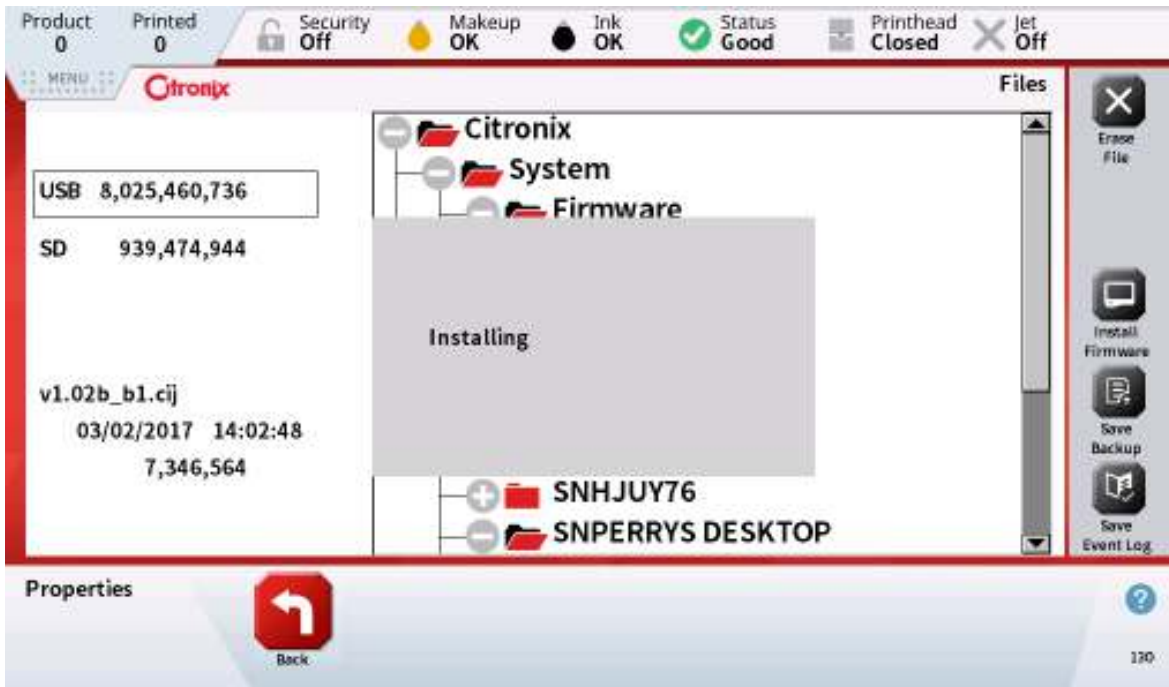

## Loading Fonts, Languages, and Keyboards

Using the same process as Updating Firmware mentioned above, install the fonts, Languages, and Keyboards onto the USB into their respective folders on the USB.

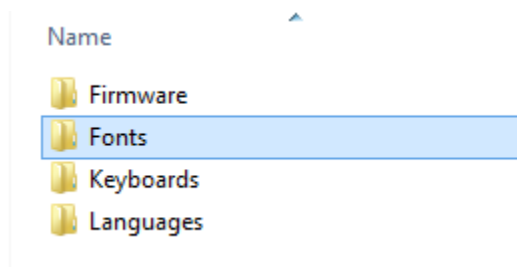

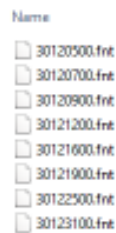

### Fonts



### Keyboards

## Name

-  ChinesePinyin.ime
-  ChineseZhuyin.ime
-  JapaneseHenkan.ime

## Languages

- Name
- Albanian\_LANGUAGE.txt
  - Arabic\_LANGUAGE.txt
  - Brazilian\_LANGUAGE.txt
  - Bulgarian\_LANGUAGE.txt
  - Chinese Trad\_LANGUAGE.txt
  - Chinese\_LANGUAGE.txt
  - Croatian\_LANGUAGE.txt
  - Czech\_LANGUAGE.txt
  - Danish\_LANGUAGE.txt
  - Dutch\_LANGUAGE.txt
  - Estonian\_LANGUAGE.txt
  - Finnish\_LANGUAGE.txt
  - French\_LANGUAGE.txt
  - German\_LANGUAGE.txt
  - Greek\_LANGUAGE.txt
  - Hebrew\_LANGUAGE.txt
  - Hungarian\_LANGUAGE.txt
  - Italian\_LANGUAGE.txt
  - Japanese\_LANGUAGE.txt
  - Korean\_LANGUAGE.txt
  - Latvian\_LANGUAGE.txt
  - Lithuanian\_LANGUAGE.txt
  - Macedonian\_LANGUAGE.txt
  - Norwegian\_LANGUAGE.txt
  - Persian\_LANGUAGE.txt
  - Polish\_LANGUAGE.txt
  - Portuguese\_LANGUAGE.txt
  - Romanian\_LANGUAGE.txt
  - Russian\_LANGUAGE.txt
  - Serbian\_LANGUAGE.txt
  - Slovak\_LANGUAGE.txt
  - Slovenian\_LANGUAGE.txt
  - Spanish\_LANGUAGE.txt
  - Swedish\_LANGUAGE.txt
  - Thai\_LANGUAGE.txt
  - Turkish\_LANGUAGE.txt
  - Vietnamese\_LANGUAGE.txt

With each (fonts, Languages, and Keyboards) you will need to load each file separately. Simply press the + symbol to the left of the file you want to install and then touch/select the file and press the install button in the Function Tool Bar on the right side of the screen.

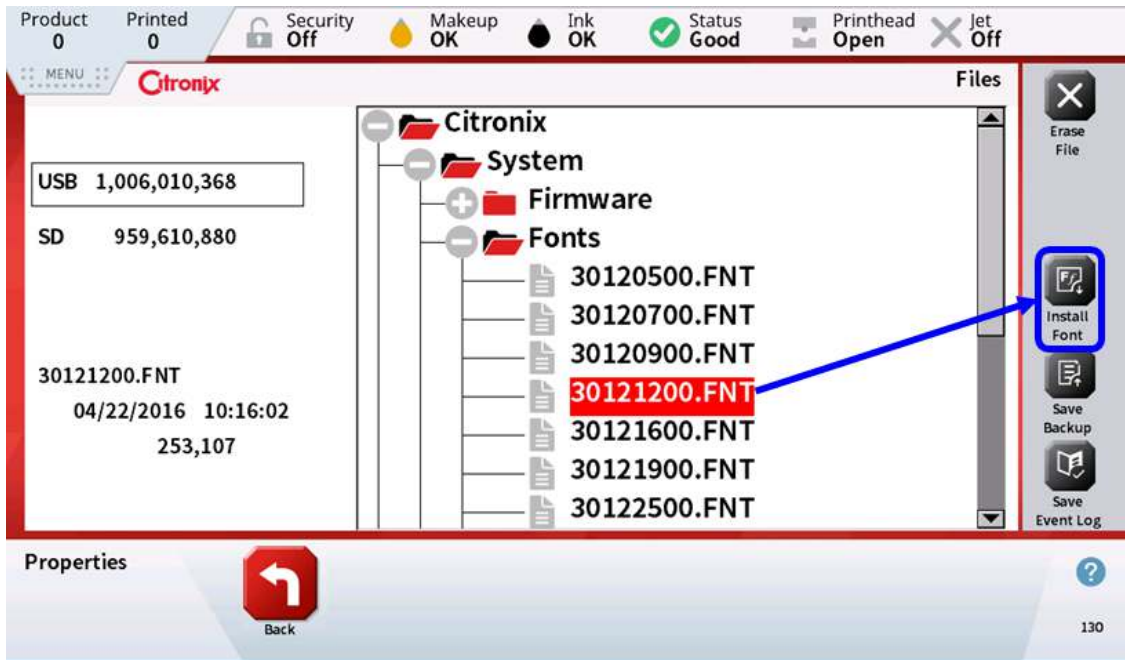

While each file is being loaded the following screen will be displayed. Wait until the screen clears before attempting to load another file.



## Uploading Graphics

Using the same process as in previous steps, load any graphic onto the USB in the following folder on the USB. Citronix/Customer/SN/Bitmaps. These files must be Monochrome Bitmaps to be used on the Citronix printer. Once the files have been loaded onto the USB and the drive plugged into the Printer's CPU board, navigate to the USB and Press the + to the left of the Bitmaps folder. This will expand the folder showing all of the graphics. Touch/highlight the graphic and press the [Install] button located in the Function Tool Bar.

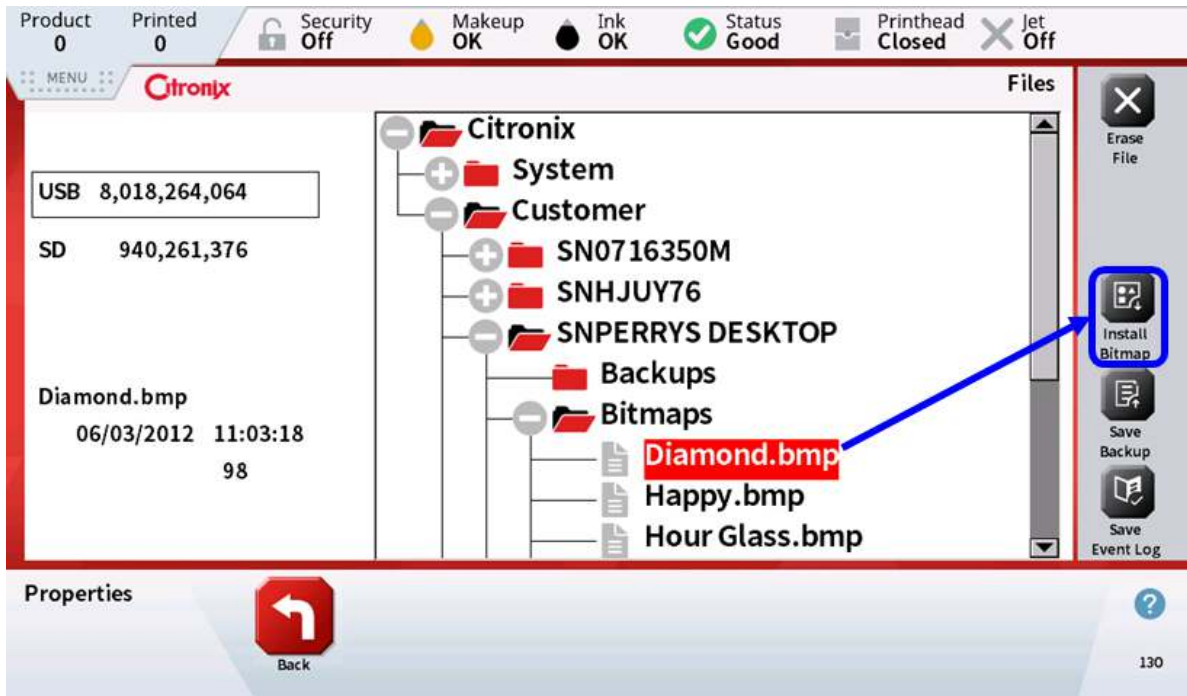

Once any/all the graphics have been loaded it will be displayed in the Graphic list, they will be ready to be inserted into any message.

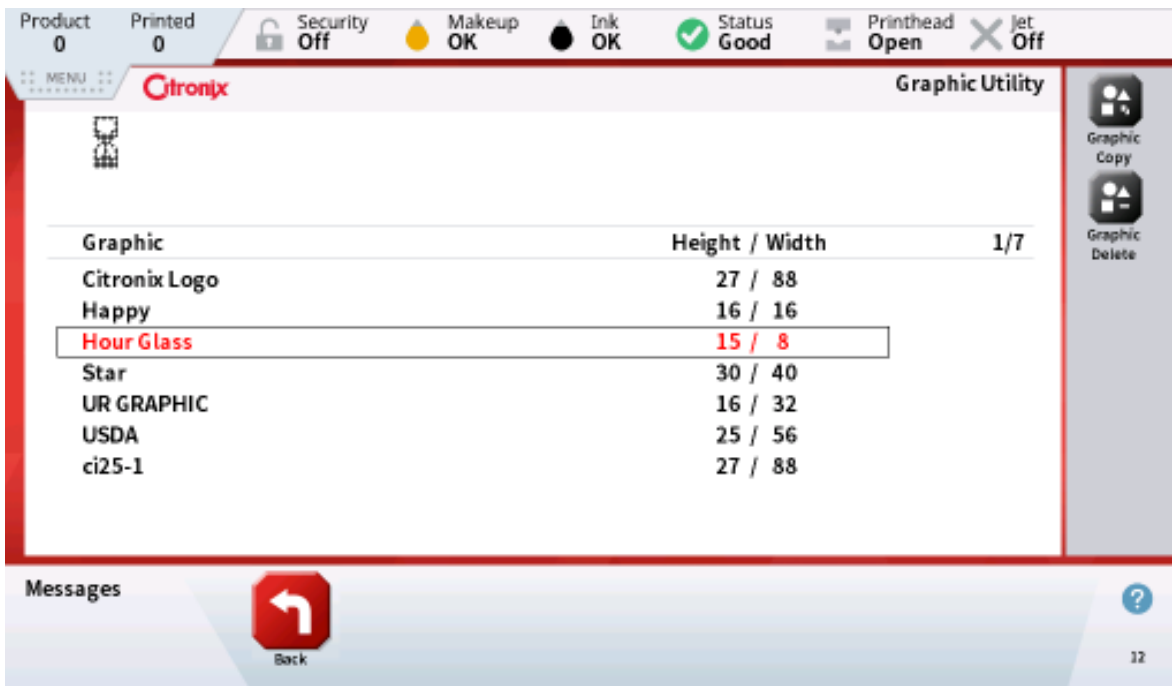

***NOTE:*** *If the graphic is not saved in the proper format, the [Install Bitmap] button will not be displayed.*

## Changing/Replacing a CPU Board

In the event that the CPU board has a catastrophic failure that cannot be resolved by rebooting the system or updating/changing the firmware the steps below will help the user to replace the CPU Board.

***NOTE:*** Always use a ground strap or wrist strap when working on or handling the CPU Board. ESD is a major contributor in many board failures!

1. Ensure the printer has been or is shut down and the power cord removed from the socket on the left side of the printer (shown below)



2. Using a 5/32 inch Allen wrench, unlock the 2 lock on the front door (tablet) assembly to gain access to the electronic section of the cabinet.



3. Unplug all of the Molex cable connections from the CPU board. (Shown below)



4. Disconnect the RFID Antenna (circled in red above) by turning the gold connector counterclockwise until the coax connector is free.
5. Carefully remove the Touch Screen's flat ribbon cable (shown below) by moving the flat black tab from the up position to the down. Then carefully pull the ribbon cable from the connector.

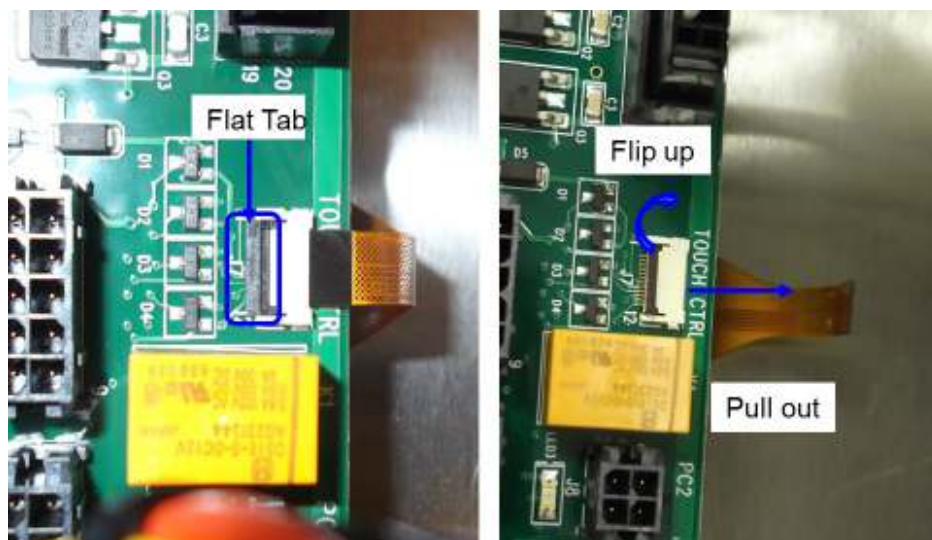

6. Now with everything unplugged from the CPU board, remove the 8 Phillips head screws from the perimeter off the board and the board will be free from the tablet door.



**NOTE:** ensure the board is place on or in an Anti-Static bag or mat to protect against ESD Damage!

7. Install the new CPU Board in the reverse order.

**NOTE:** when installing the Touch screen flat ribbon cable, take care NOT to bend or pinch the ribbon cable. (See below)

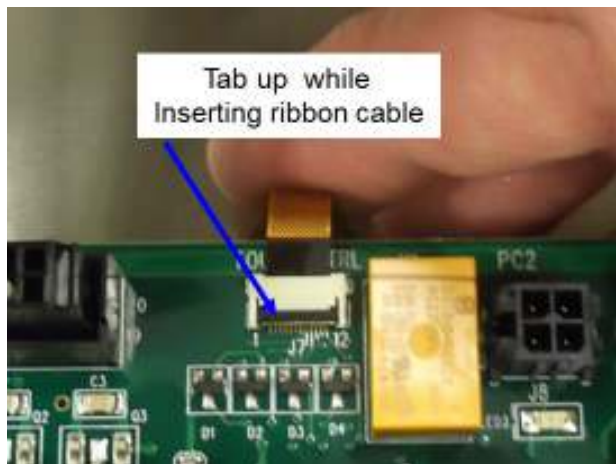

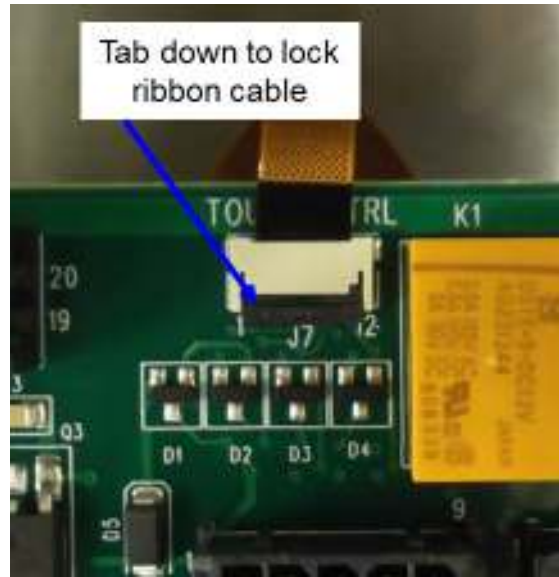

When all of the connections are fitting, reconnect the power cable into the socket.

### Changing or Cleaning a Nozzle Plate

In the event a severe clog occurs that cannot be overcome through the Printhead cleaning routine or the Backflush service routine, the Nozzle Insert may be required to be more thoroughly cleaned or replaced.

To clean or replace the Nozzle Plate:

1. Stop the Jet.
2. Release the thumbscrew securing the Printhead front cover and slide off the cover.
3. Remove the two screws that secure the Drop Generator and remove from Printhead base. This provides direct access to the Nozzle. Do not disconnect any cables.
4. Remove the two Nozzle screws that secure the Nozzle to the Drop Generator and remove the Nozzle from the Drop Generator with a gentle rotating motion back and forth until the Nozzle is free from the Drop Generator.



5. Either flush or ultrasonically clean the Nozzle or replace with new Nozzle Plate. The Nozzle Plate is replaced by simply pushing in and securing with the two Nozzle screws.
6. Reinstall the Drop Generator in the reverse order as it was removed in the previous step 3
7. Finalize the routine by following the Calibration Routine as described in Section 8

**NOTE:** A Calibration Routine is required to complete this process. See Section 9 Calibration

## Ultrasonically Clean a Nozzle Plate

An Ultrasonic Bath should be used to clean a Nozzle when a backflush does not resolve a fault with the Nozzle.

### **Tools/parts:**

- Ultrasonic Cleaner (not heated)
- Microscope (optional)
- MEK
- Ethanol
- Water
- Clean dry air (canned air recommended)

**CAUTION:** Do NOT use a heated ultrasonic bath – damage will result to Nozzle and Nozzle body.

### Stage 1:

1. Clean substantial deposits of Ink or other debris with MEK (using a squirt bottle).
2. Place the Nozzle in a small beaker of the proper solvent for your Ink type. Place the beaker in the ultrasonic bath, lightly floating in water for 3 to 6 minutes.
3. Remove the Nozzle and dry it with clean air.
4. Inspect the interior of the Nozzle using a microscope. If debris remains, continue to Stage 2.

### Stage 2:

1. Place the Nozzle in a small beaker of PHETCH (Citronix part number 016-1016-001). Place the beaker in the ultrasonic bath, lightly floating in water for a maximum of 5 minutes.

**CAUTION:** Use a clean beaker (free of MEK) for this process. Mixing of solvents and/or water may clog the Nozzle beyond recovery.

2. Remove the Nozzle and dry it with clean air.
3. Inspect the interior of the Nozzle using a microscope. If debris remains, continue to Stage 3.

### Stage 3:

- Replace the Nozzle as described in previous procedure.

## Charge Electrode Block Alignment

To align the Charge Block so that visually the ink stream is centered in the slot in the Charge Electrode.

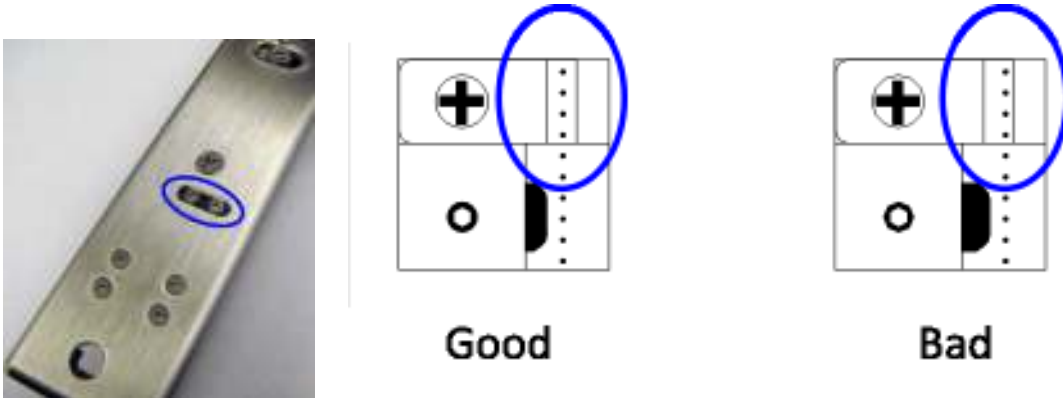

Start the Jet, ensuring the Overrides are still on. Observe the Jet's position in the charge slot and adjust the block so that the Jet is in the center of the charge slot. This adjustment may be accomplished by first loosening the mounting screws and then gently levering the Charge Block using a screwdriver. Use an eyeglass to confirm that the Jet is centered. Carefully tighten the securing screws.

### Changing Ink, Makeup or Ink, Makeup Tank (Ink Refresh)

It may be necessary to change the Ink, Makeup or their tanks for various reasons. This could be due to the machine not being used for a long period of time, expired Ink shelf life or contamination from the use of incorrect Ink. This procedure can also be used to ensure the correct viscosity of the Ink or to remove the fluid from the system prior to shipping. Follow shipping preparation guidelines prior to shipping.

**PERSONAL INJURY:** Make sure to wear proper Personal Protection Equipment (PPE) when changing Ink, Makeup, Ink Tank, or Makeup Tank.

To change Ink, Makeup or the Ink/Makeup Tank

1. Turn the power off using the appropriate shutdown routine.
2. Remove the Ink System housing cover.
3. Loosen the Ink Tank hold down screw (shown in Pic 2) or the Service Module Base (shown in Pic 3)
4. Remove the Ink fill tube by first removing the 3 screws securing the Ink Fill Port to the cabinet, then pressing the top of the quick disconnect fitting located on the top of the Ink Manifold (shown in Pic 1) and pulling the tube up and out of the Ink Manifold or the Makeup fill tube by removing the 3 screws securing the Makeup Fill Port from the cabinet then pressing the top of the quick disconnect fitting located on the top of the Makeup Manifold.
5. If the Makeup tank is being removed, swing the Service Module Base towards the Ink Manifold to allow access to the Makeup Manifold.
6. Using a 5/32" allen wrench, turn the two manifold locking cams ¼ turn counterclockwise (shown in Pic 1 for the Ink Manifold).
7. While lifting the Manifold out of the tank, carefully remove the tank out of the Ink system. Use absorbent cloths to collect excess Ink as the Ink / Makeup pickup and return lines are removed from the tank.
8. Discard Ink or Makeup in accordance with local regulations.
9. Clean the inside of either tank with the appropriate solvent for the ink type used.
10. Replace Ink or Makeup tank by reversing the above steps 3 thru7.

11. Refill the tank with new Ink or Makeup, taking care to use the correct Ink type following the Add Ink/Makeup procedure mentioned in Section 3 of this manual.
12. Refit the Ink System housing cover.

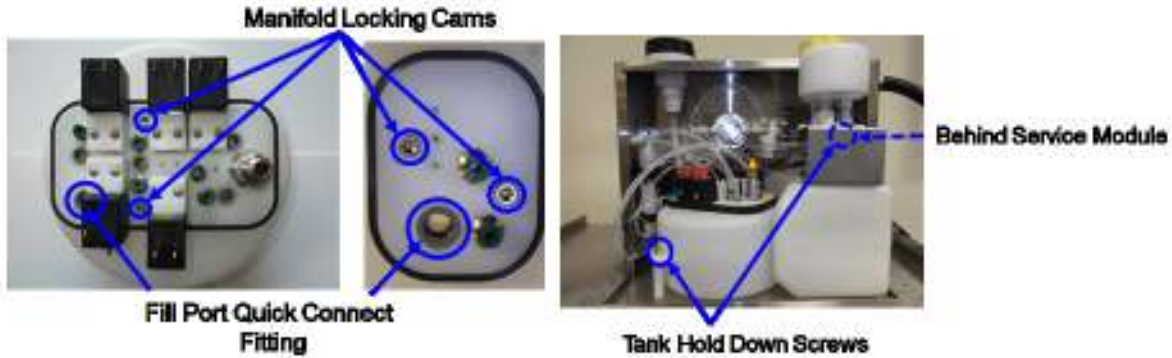
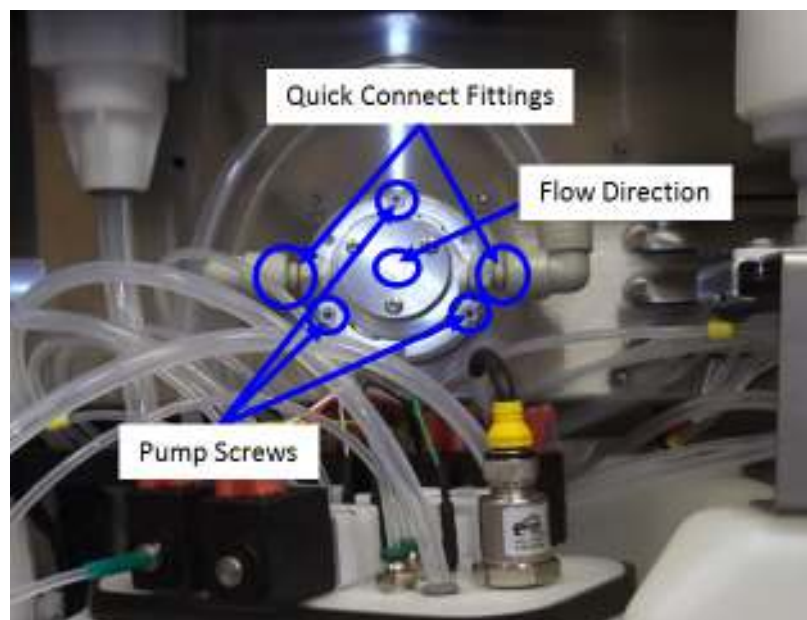

Fig 1

Fig 2

## Changing the Ink System Pump

1. Disconnect the Ink tubes from the quick disconnect fitting on each side of the pump. Place an absorbent material such as a paper towel to catch any Ink that is left in the pump head.
2. Remove the three pump screws that secure the pump to the pump motor.
3. Carefully remove the pump assembly from the motor.
4. The pump is reinstalled using the reverse procedure. Ensure that the pump flow direction is correct as shown below.



**NOTE:** *If the pump is intended to be re-used, make sure the pump is cleaned using the appropriate Cleaning Solvent for the Ink type being used. Failure to do so will result in the Ink drying in the pump gears and causing damage.*

## Changing / Cleaning an Ink System Valve and Gasket

1. Remove the Ink system housing cover.
2. Remove the Solenoid from the valve stem by removing the plastic hold-down clip on the end of the Solenoid and removing from the valve.
3. Remove the two screws securing the valve to the Ink manifold. Remove the valve from the manifold, taking care not to lose the valve gasket. Flush the valve with solvent to prevent Ink from drying in it.
4. Replace the cleaned valve, replacement valve, or replacement gasket.

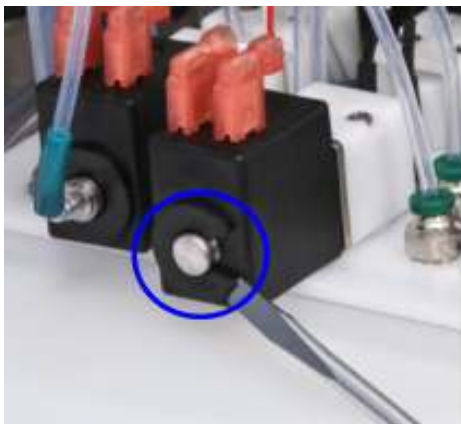

**NOTE:** *If the valve is intended to be re-used, make sure it is cleaned using the appropriate Cleaning Solvent for the Ink type being used. Failure to do so will result in the Ink drying in the valve, causing damage.*

## Changing / Removing the Pressure Transducer

1. Turn the power OFF using the appropriate shutdown routine.
2. Remove the Ink System housing cover.
3. Loosen the Ink tank hold down screw.
4. Remove the Ink fill tube by pressing the top of the quick disconnect fitting located on the top of the Ink Manifold (shown in Section 9.4 Pic 1) and pulling the tube up and out.
5. Swing the Main Ink Filter out and lift out the Ink tank from the ink cabinet.
6. Pull the Ink tank & Manifold assembly out.
7. Cut the cable ties from the Ink System cable harness.
8. From the Electronic compartment find and loosen the grommet nut on the Pressure Transducer cable and pull the Pressure Transducer cable and plug through the Ink System wall when replacing the Transducer cable. Or unplug the cable from the Transducer when replacing only the Pressure Transducer.
9. Using the appropriate wrench, unscrew the Pressure Transducer from the manifold.
10. Do not use thread tape or sealant and do not over-tighten.
11. Replace using the reverse procedure. Then ensure the cable is re-installed correctly and that the cables are secured away from the pump motor.
12. Refit the Ink System housing cover.

**CAUTION:** Do not unscrew the transducer without first pulling the cable through the Ink system wall or disconnecting the cable from the transducer. The cable will twist and damage may result.



## Changing / Cleaning the Pressure Restrictor

The Pressure Restrictor may require cleaning or replacement due to the nature of the operation and size of the opening.

The Pressure Restrictor is located behind the grub screw on the right front side (shown below in Pic 1) near Pressure Transducer side of the Manifold.



**Pic 1**



**Pic 2**

1. Loosen the Ink tank hold down screw (described above in Changing Ink, Makeup or Ink, Makeup Tank).
2. Remove the ink fill tube by pressing the top of the quick disconnect fitting located on the top of the Ink Manifold (described above in Changing Ink, Makeup or Ink, Makeup Tank) and pulling the tube up and out.
3. Use a 5/32" allen wrench, turn the two manifold locking cams ¼ turn counterclockwise (described above in Changing Ink, Makeup or Ink, Makeup Tank).
4. Lift the Manifold out of the tank and tilt it so that it sets tilted on the Ink tank.
5. Use a 1/8" allen wrench, remove the grub screw circled above in Pic 1. Clean with the proper solvent and set aside.
6. Use a 1/16" allen wrench, insert into the hole in the manifold and carefully unscrew the restrictor from the manifold.
7. Carefully rinse the hole and inspect for dirt and/or any other debris.
8. If the restrictor is clogged, simply wash with Cleaning Solvent until the clog is removed. Hold the restrictor up to the light to inspect for possible blockages.
9. Reinstall or replace the restrictor into the manifold. Screw it into the manifold 10 complete turns and refit the grub screw until the grub screw o-ring can be seen around the head of the grub screw. DO NOT overtighten as this can cause damage to the Ink Manifold.
10. Reinsert the Ink Manifold back into the Ink tank and make sure the manifold gasket seals all the way around and is flat between the tank and Manifold and secure the two manifold locking cams by turning them ¼ turn clockwise.
11. Reinsert the Ink Manifold and tank assembly back in place and secure the tank hold down screw.
12. Refit the fill tube into the quick disconnect on the manifold.
13. Refit the back cover and tighten the locking cam.

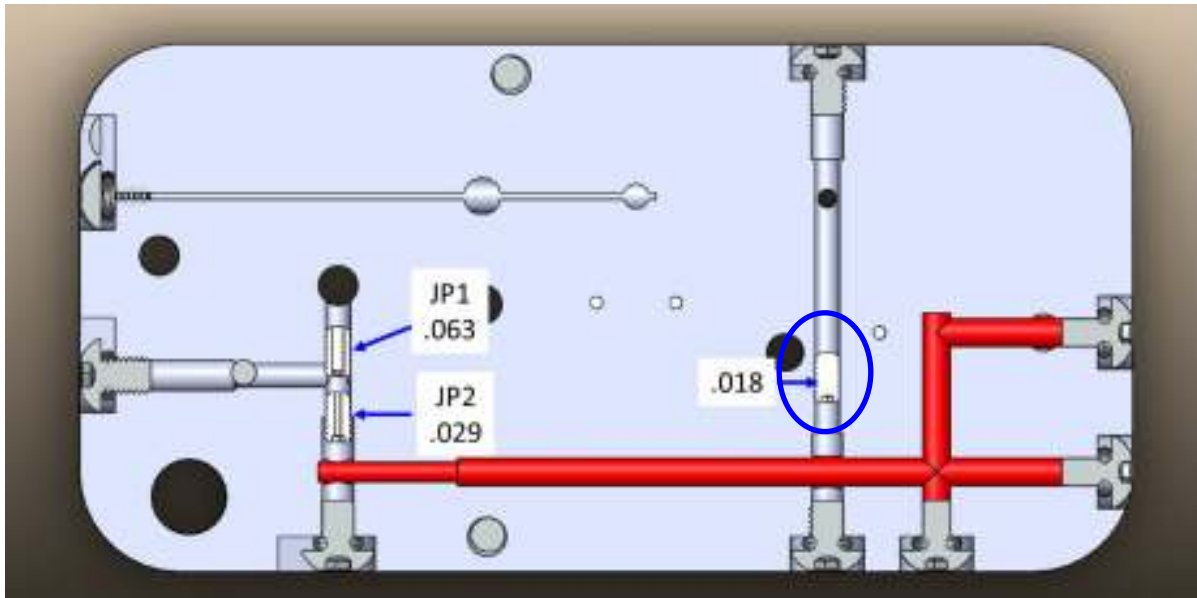

### Changing / Cleaning the Venturi Restrictors

The Venturi Restrictors may require cleaning or replacement due to the nature of the operation and size of the opening.

1. Remove the Manifold from the Ink tank as described in the previous step (Changing / Cleaning the Pressure Restrictor)
2. The Venturi Restrictors are located behind the Grub screw on the left front side of the Manifold (shown below in Pic 1). It is necessary to remove this grub screw to gain access to the restrictors. To remove the grub screw, loosen with a 1/8" allen wrench and remove.
3. Once the grub screw has been removed, use a 1/16" hex key (003-1051-001) and remove both of the Venturi restrictors.
4. The manifold is threaded only a short way. If either Venturi restrictor does not come out on the end of the hex key, turn the manifold down and gently tap it until the insert falls out.
5. Clean or replace the restrictors ensuring to replace them in the correct order (see Pic 3 below). Before reinstalling, hold them up to the light to ensure that they are clean.
6. The restrictors must be screwed into the manifold to a precise depth. This is accomplished by first removing the Vacuum valve.
7. Looking into the first hole of the valve, screw in PJ1 (.063 restrictor) until it is covering 80% of the hole with the open section closest to the back of the printer (see Pic 3 for this detail).
8. Now take JP2 (.029 restrictor) and screw in behind JP1 until it touches PJ1 then screw it back (counterclockwise) 2 ½ turns.
9. Replace the gutter valve and the Grub screw until the grub screw o-ring can be seen around the head of the grub screw. DO NOT overtighten as this can cause damage to the Ink Manifold.
10. Reinsert the Ink Manifold back into the Ink tank and make sure the manifold gasket seals all the way around and is flat between the tank and Manifold and secure the two manifold locking cams by turning them ¼ turn clockwise.
11. Reinsert the Ink Manifold and tank assembly back in place and secure the tank hold down screw.
12. Refit the fill tube into the quick disconnect on the manifold.
13. Refit the back cover and tighten the locking cam.

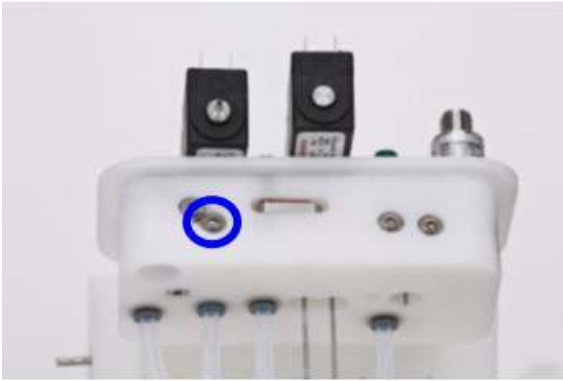

**Pic 1**



**Pic 2**

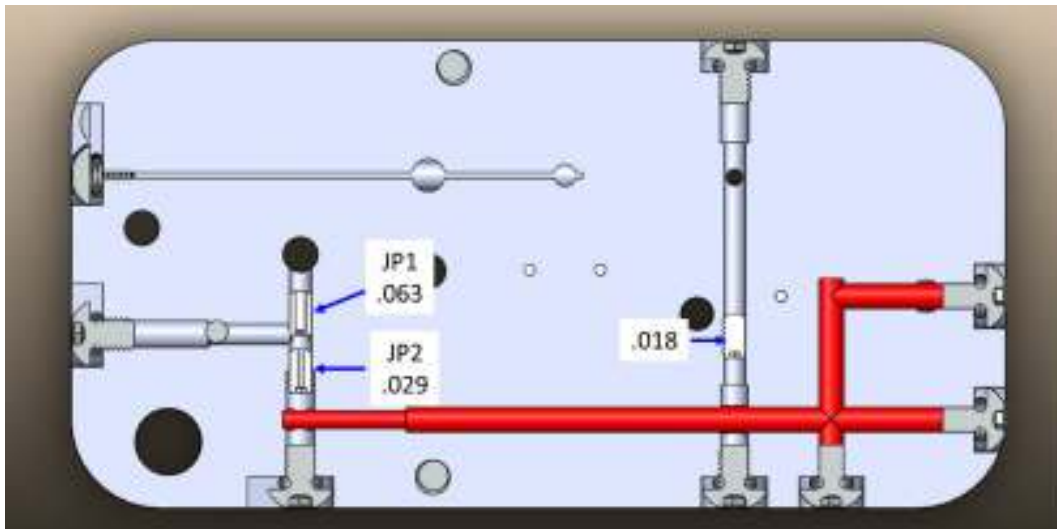

## SECTION 7: COMMUNICATIONS

### Contents

	Page
Overview .....	7-2
Serial and Ethernet.....	7-2
RS232 Port .....	7-2
RS232 Settings.....	7-3
RS232 Timings .....	7-3
Ethernet.....	7-4
Ethernet Ports.....	7-5
Ethernet Timings.....	7-5
Printer Ethernet Settings.....	7-5
Command Interface .....	7-8
Videojet Emulation .....	7-11
Acknowledgements.....	7-12
Web Browser Utility .....	7-13
Firmware Upgrade .....	7-14
Backup.....	7-15
Restore .....	7-17

## **Overview**

This section focuses on the Communications Interface for the Citronix Printer. There are two main protocols that can be used to remotely interface with the Printer: Serial and Ethernet.

The Ethernet Web interface can be used to:

- View and control the Printer via a Web interface.
- View and download event logs.
- Update firmware on the Printer.
- Backup and restore all Graphics, Messages and Properties of the Printer.
- Upload/Download Language files to the Printer.
- Upload Graphics to the Printer.
- Upload Font files to the Printer.
- Upload IME files to the Printer.
- Upload Keyboard image files to the Printer.

The Ethernet interface can be used to:

- Backup and restore all Graphics, Messages and Properties of the Printer.
- Perform commands to select messages and update text in messages.
- Perform commands to control the Printer.
- Receive acknowledgements of Photocell trigger, Print Ready and Print Complete.
- Receive warnings/errors.

The RS232 or Serial interface can be used to:

- Backup and restore all Graphics, Messages and Properties of the Printer.
- Perform commands to select messages and update text in messages.
- Perform commands to control the Printer.
- Receive acknowledgements of Photocell trigger, Print Ready and Print Complete.
- Receive warnings/errors.

## **Serial and Ethernet**

An external connection may be made to the Printer by either a RS232 serial connection or an Ethernet connection.

The Command Interface is supported on both the RS232 connection and the Ethernet connection. For ci3200 and ci3300 Printer models, the Command Interface is supported only on the RS232 User Serial Port.

### **RS232 Port**

The PC board has two serial port connectors. The User Serial Port is labeled “Serial #2” J21. “Serial #1” J20 is reserved for debugging.

The serial cable is a non-standard 10-pin ribbon connector to DB9 that is available from Citronix in lengths up to 25 feet.

If frequent connecting and disconnecting to the RS232 serial port is to be done, Citronix recommends that a short serial cable be installed on the board and through the external housing with a strain relief fitting. The end of this cable may be used for the connection.

## RS232 Settings

The default serial port settings are as follows:

- Baud Rate 115.2K
- Data Bits 8
- Stop Bits 1
- Parity None

These settings must match the serial settings at the other end of the RS232 cable.

## RS232 Timings

The Printer's RS232 interface does not use any flow control. In order to avoid buffer overflows, an external controller should pause occasionally when sending large amounts of data or sending many small commands. The pause must be 1ms after every 256 characters or less. This is done in Hyperterm by setting the line delay to 1. (Hyperterm no longer comes with Windows OS, other terminal emulators such as putty or CoolTerm are available for download.)

Internal buffer processing must also be performed. A carriage return is required at the end of every command. When sending large amounts of data for a Restore (RR) command, a Message (ME) command, or a Graphic (GR) command, a carriage return must be used every 1000 characters or less, at an appropriate spot in the data stream – not in the middle of a data field.

Open a RS232 Serial port session with putty (COM4 has a FTDI RS232 to USB converter in this example – default serial settings 115200,8,N,1).

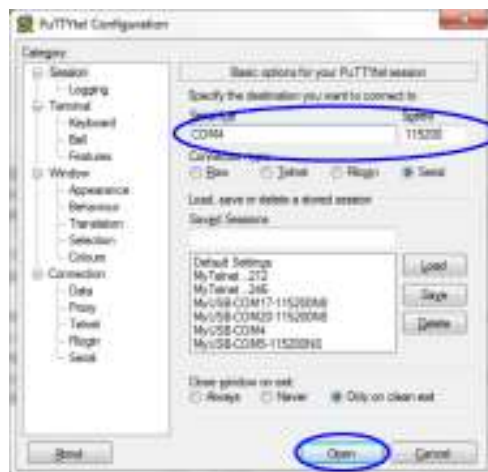

Press the “Open” button.

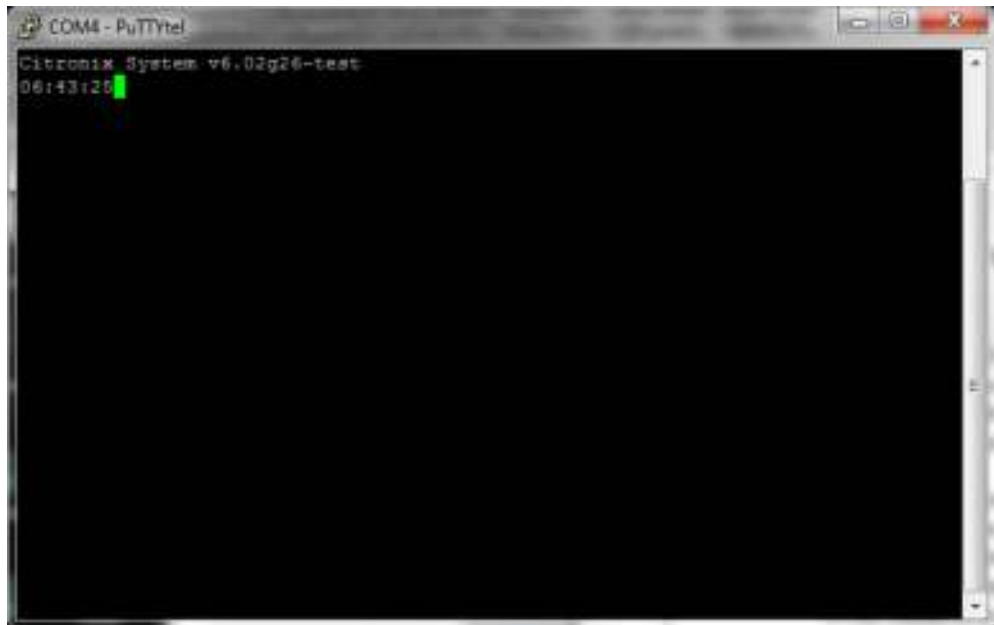

The Citronix version and time header is only displayed if a serial connection is open before the Printer is powered on; otherwise, the terminal will be blank.

Type in the "ST" command followed by a carriage return to get the Printer status.



## Ethernet

The Ethernet connection is made to the P1 connector. This is a standard RJ45 connector. If the Printer is to be directly connected to a computer, a crossover cable must be used. If the Printer is to be connected to an Ethernet hub, switch or router, a standard Ethernet cable must be used.

On the side of the electronics board, approximately 2 inches from the P1 connector are six LEDs used to monitor the Ethernet connection. If the other end of the Ethernet cable is connected to an active device whose interface is enabled, the DPX, LNK and SPD LEDs should light. The RX LED should blink in response to standard Ethernet traffic on the line. This blinking should correspond to the LED on the switch or router that it is connected to. This LED is a very low-level function and does not mean that this Printer is receiving data intended for it.

## Ethernet Ports

There are two Ethernet TCP/IP ports used by the remote command interface. Both ports process all commands identically. Each port may have only one connection at a time.

A connection to Port 23 (Telnet port) will receive a transmission that indicates that a good connection was made. It denotes the version of the firmware. Port 23 will also receive asynchronous messages about warnings and errors and the acknowledgements generated as a result of configuration properties. The warning and error messages may be turned on or off by the Error Property on the Host Interface screen. Port 23 was developed to be used by a person using a terminal emulator.

Port 3028 was developed to be used by a remote computer. There is no welcome greeting or asynchronous messages. The only responses are the result of commands.

## Ethernet Timings

The Ethernet ports do not need flow control.

Internal buffer processing must be performed. A carriage return is required at the end of every command. When sending large amounts of data for a Restore (RR) command, a Message (ME) command, or a Graphic (GR) command, a carriage return must be used every 1000 characters or less, at an appropriate spot in the data stream – not in the middle of a data field.

## Printer Ethernet Settings

If the Printer is directly connected to a computer, a crossover Ethernet cable must be used. A normal Ethernet cable will not work. The Printer must be assigned an Internet address and a subnet mask. Typical values for these are 10.1.1.11 and 255.255.255.0. The connected computer is assigned 10.1.1.10 and 255.255.255.0.

If the connected computer is normally connected to a LAN, it would have been assigned an Internet address on that LAN. If this address can be determined, the computer address and other connection information can be left without modification and the Printer Internet address and subnet mask assigned to be compatible.

The Printer does not use DHCP to assign a dynamic Internet address. A static Internet address must be assigned to the Printer by the IT administrator of the company in which the Printer is installed. This assigned Internet address and the subnet mask must then be entered.

This Internet address should be entered into the Printer before the Ethernet cable is plugged into the Printer. If the current Internet information in the Printer is not correct for the LAN, it may cause LAN problems with other Internet devices.

The Printer may be assigned an Internet nickname. The Printer supports the protocols to announce its name and to respond to name inquiries.

The naming rules are that the Internet nickname:

- Is limited to 15 characters
- Has only UPPERCASE letters, digits and a hyphen
- Must start with a letter
- Must not end with a hyphen

Examples of valid names are PRINTER2, BOTTLER03, and FILLER-LINE-4.

This Internet nickname may be used by any software that supports WINS or DNS name resolution. To test the connection, the name may be used in the ping command. The name may be used in a Web browser to look at the display screen. On a Printer, the Printer keyboard is displayed in the Web browser and may be used for full remote control of the Printer.

Open a Telnet session with putty.

Enter the IP address of the Printer (example IP 10.1.50.226).

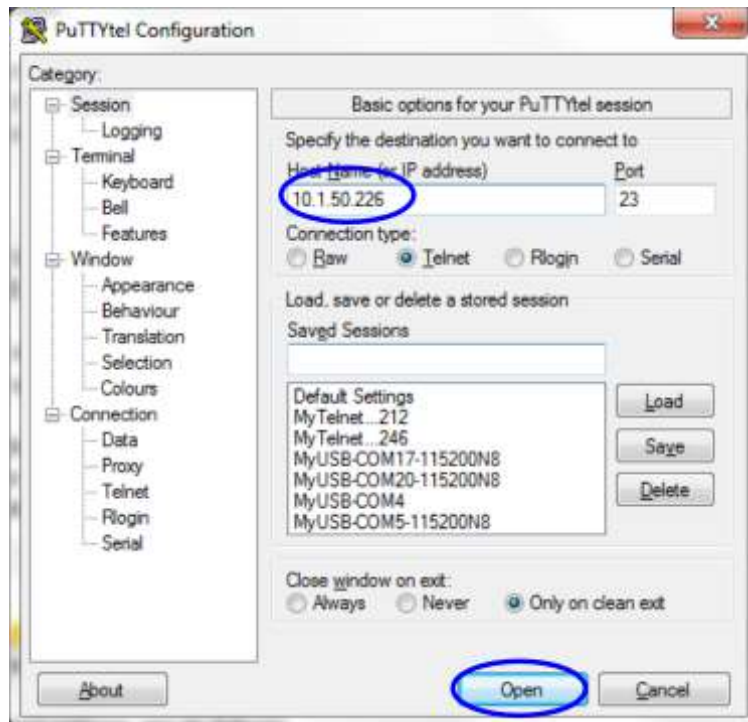

Press the “Open” button.

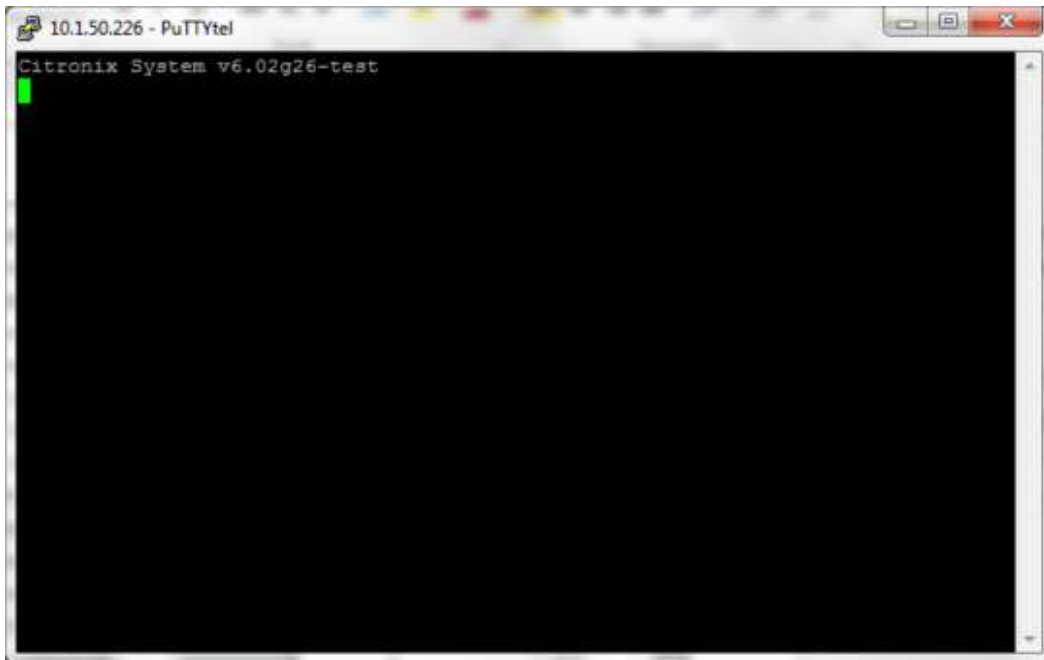

Type in the "ST" command followed by a carriage return to get the Printer status.

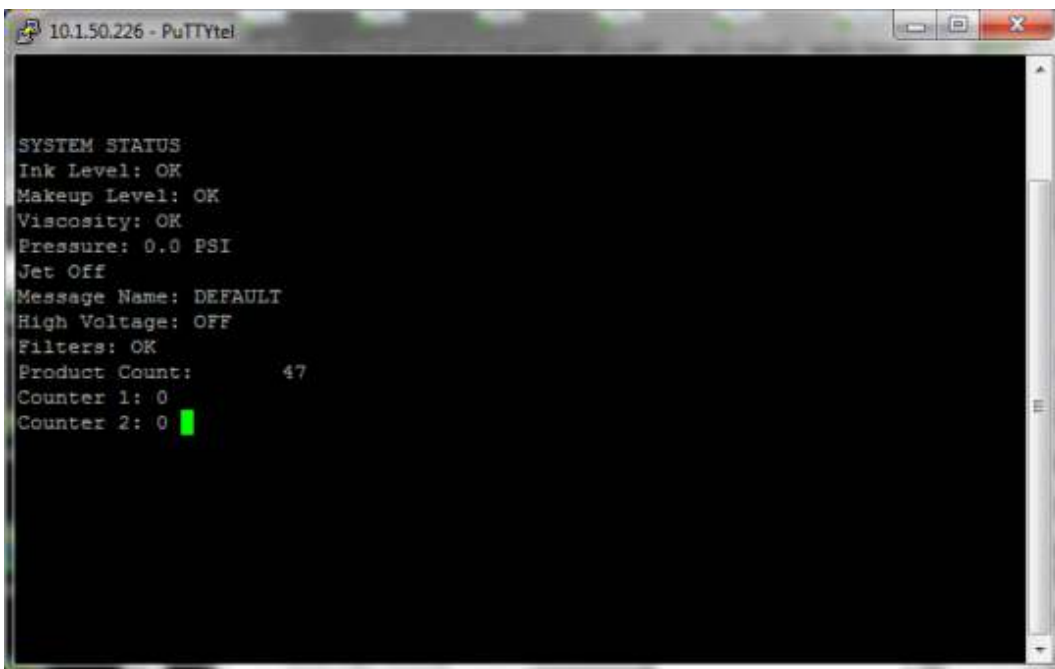

## Windows Settings

The Windows networking information must be updated to work with the Printer. These are accessed through Control Panel -> Network Connections -> Local Area Connections -> Properties -> Internet Protocol (TCP/IP). Some Internet knowledge is required. All features and options cannot be covered here.

No change should be necessary if the Printer and the computer are both properly connected to the LAN, the Internet address or Printer nickname.

## Command Interface

The following table lists the commands processed by the remote communications interface. The commands are not case-sensitive.

In all the examples, <CR> will indicate the carriage return character, hex 0D, decimal 13.

Command	Example String	Name	Options	Description
AC	ACY<CR>	Acknowledge Ready	Y/N	Will send "X" when print buffer is created
AU	AUY<CR>	AutoPrint	Y/N	Automatic Print Signal Generation
BB	BB<CR>	Backup	None	Backs up all system and message settings
BO	BO1<CR>	Bold	0-9	Inputs bold type of character in message defaults
C1	C1<CR>	Counter Value	None	Displays Counter 1 current counter value
C2	C2<CR>	Counter Value	None	Displays Counter 2 current counter value
CL	CLY<CR>	Clear Buffer	Y/N	Clears current print buffer (to generate a new one)
CM	CM<CR>	Clean Messages	None	Clears message storage (deletes all messages)
CO	See attached	Counter	See below	Set up sequential counting of products.
CP	CP<CR>	Product Count	None	Displays current product count.
CR	CR<CR>	Counter Reset	None	Allows reset of the Product Counter.
CS	CS<CR>	Count Status	None	Continuous display of counters.
DA	DA12232003<CR>	Date	MMDDYY	Sets system date.
DE	DE1500<CR>	Delay	0-999999	Delay between product and printing.
EN	ENY<CR>	Encoder	Y/N	Select an external shaft encoder.
EX	EX30<CR>	Expiration Date	0-9999	Number of days past current date.
GA	GA<CR>	Gap	0-9	Inputs a space between characters in message defaults.
GL	GLY<CR>	Global Lock	Y/N	Set message settings format, Y = Global basis, N = Message basis
HE	HE<CH>	Height	120-255	Input height of character in message defaults.
LE	LE<CR>	Error Log	None	Displays error log.
LF	LF<CR>	Log Off	None	Logs off the current user

LN	LNBOB,BOB	Log On	LNname, password	Logs on a user
MD	See below	Message Data	See below	Download data to existing fields in message.
ME	See below	Message	See below	Allows creation, and editing of messages.
ML	ML<CR>	Message List	See below	Sends a list of messages to host port.
MR	MR<CR>	Message Buffer Reset	None	Clears current print buffer (to generate new one).
MS	MSUSCS<CR>	Measurement System	USCS/METRIC	Sets Measurement System.
MT	MT<CR>	Manual Trigger	None	Same as a Photocell Trigger Edge
OR	ORUU<CR>	Orientation	UU, UD, MU, MD	Selects orientation of printed characters in message defaults.
PE	PEY	Printer Enable	Y/N	Enable or Disable printing
QS	QS<CR>	Quick Start	None	Enables or disables Jet Flush or Smart Clean.
RO	RO0345<CR>	Rollover	Any time	Time when system date is advanced.
RR	RR<CR>	Restore	Restore file	Restores all system and message settings.
RS	RS<CR>	Restart or Reboot	None	Performs a soft reset of Printer.
SH	See below	Shift Set	See below	Input shifts to allow printing of shift codes in message defaults.
SI	Select Interpreter	Message List and Select	See below	Provides the ability to receive list of messages and select a message for printing.
SJ	SJ<CR>	Start/Stop Jet	Y/N/None	Start or Stop, or change the Jet.
SM	SM(MSG)<CR>	Select Message	See below	Select stored message for printing.
SS	SS<CR>	Status	None	Retrieves status and auto updates every second. Use SS to disable if enabled.
ST	ST<CR>	Status	None	Retrieves status information.
TI	TI023400<CR>	Time	Any time	Sets system time.
TR	TRR<CR>	Trigger Edge	R/F	Sets edge of photocell signal to trigger print.
WI	WI5<CR>	Width	0-255	Sets Print width (print resolution) in message defaults.

This command provides access to multiple fields:

- Current: 00000050 (interim start value)
- Upper: 99999999 (enter upper limit value)
- Lower: 00000000 (enter lower limit value)
- Increment: 999 (enter increment value)
- Repeat: 001 (enter repeat value)
- Print Leading Zeros: Y (enter Yes or No)
- Number of Digits: 6

*Example string: CO0,0,10000,000,001,Y,6<CR>*

**MD (Message Data)**

This command provides the ability to download data to a pre-existing message selected for printing. Each data field is entered and separated by a comma. The data is loaded in the order of which the data fields were created. The comma after the MD and the comma before the <CR> are optional. To use a comma as data, a TAB character (decimal 9) may be used as the field separator. To use one data field with a comma as data, a TAB must be used after the MD.

*Example string: MD,xxxxxxx,iiiiiiiiiiii,nnnnnnnnnn,bbbbbbbbbbb,<CR>*

Explanation:

- x = Field 1 Data
- i = Field 2 Data
- n = Field 3 Data
- b = Field 4 Data

\*Additional fields can be added by using the “,” as the separator.

**ME (Message Command)**

This command enables the ability to create a message externally.

**ML (Message List)**

This command allows the list of messages to be delivered from the ci5000 Series Printer to the host device.

*Example output:*

Available Messages:

Date	Time	Name
11/29/2020	12:16	1
11/29/2020	12:16	2
12/5/2020	12:24	*Test
00/00/0000	0:00	DEFAULT

**SH (Shift Set)**

This command provides access to the following fields:

- Shifts: 2 (enter value 1, 2 or 3 dependent on time values to use)
- Shift 1: HH MM SS (enter start time for beginning of shift 2)
- Code: XXX (enter up to three character code for shift 1)

Shift 2: HH MM SS (enter start time for beginning of shift 2)  
Code: XXX (enter up to three character code for shift 2)  
Shift 3: HH MM SS (enter start time for beginning for shift 3)  
Code: XXX (enter up to three character code for shift 3)

*Example string:*

`SHn,bbbbbb,xxx,eeeeee,xxx,cccccc,xxx<CR>`

**Explanation:**

n = SHIFT number

bbbbbb = Shift 1 BEGIN time in HHMMSS format

xxx = Shift 1 code (any three characters)

eeeeee = Shift 2 BEGIN time in HHMMSS format

xxx = Shift 2 code (any three characters)

cccccc = Shift 3 BEGIN time in HHMMSS format.

xxx = Shift 3 code (any three characters)

### SI (Select Interactively)

This command allows selection of a Message after the list of messages have been delivered to the host device via number of messages in the list.

*Example output:*

Available Messages (left column number)

sel	Date	Time	Name
1	11/29/2020	12:16	1
2	11/29/2020	12:16	2
3	12/5/2020	12:24	*Test
4	00/00/0000	0:00	DEFAULT

Enter Selection->(x to exit)

### SM (Select Message)

This command allows selection of a Message for printing remotely by Message name or Message number.

Example string: SMmessagenam<CR>

***NOTE:*** *If the name is not found, the Printer will list all the messages in the Printer.*

### Videojet Emulation

When operating in One-For-One mode, the Printer requires new data for each printed message. The normal format of this data is the MD (Message Data) command.

The Printer also supports three modes of emulation for VideoJet (VJ) data. The VJ Emulation Interface Property can be set to:

- YES – The Printer reads two lines of data and combines them into one MD command (MDline1,line2<CR>).
- CC1LINE – The Printer reads one line of data and converts it into one MD command (MDline1<CR>).
- CC2LINE – The Printer reads one line of data, splits off every other character into two lines and combines them into one MD command (MDline1,line2<CR>). For example, if “A1B2C3D4” is received, it makes one MD command (MDABCD,1234<CR>).

**WARNING:** *The Printer supports the emulation of VJ data transmissions. The Printer may have some problems with VJ timing. The Printer requires 20 - 40 milliseconds to make a print buffer, depending on the complexity of the message. The Photocell Trigger to print the message must not arrive before the print buffer is ready.*

**WARNING:** *When in VJ emulation mode, all input is read as VJ data. The Printer will not process any input as Citronix commands.*

**WARNING:** *When connected to an external controller that is transmitting VJ data, the emulation mode should NOT be turned off. Doing so will return to the normal interface mode in which the Printer expects Citronix commands. Some VJ data could look like a Citronix command and cause unpredictable results such as starting or stopping the Printer. The interface cable should first be disconnected from the Printer before turning off the VJ emulation.*

## Acknowledgements

To assist in the control and timing of remote communication applications, the Printer has three Acknowledgement options. These Acknowledgements may be used at any time and for any reason such as performance evaluation or data logging. Their use is not restricted to the original mode for which they were designed.

The Acknowledgements will be sent on the Serial Port and on Ethernet Port 23. They will not be sent on Ethernet port 3028.

### Acknowledgement Ready

Acknowledgement Ready will signal an external computer that a print buffer has been created and is ready for printing. This Acknowledgement has an option either to transmit a single character “X,” or, if in One-For-One mode, to transmit back the MD command as a confirmation of the new data that was inserted into the message. The “X” is transmitted by itself; the MD command will end with a <CR>.

Acknowledgement Ready will be transmitted whenever a new print buffer is created – whether requested by the external computer, or whether built by the Printer.

The Printer will build a new print buffer under the following circumstances, as well as others that are not documented here:

- If the message contains an Autocode to print the seconds, and the current buffer is more than 1 second old.
- If the current buffer is more than 1 minute old.

- If any System Property is changed that may affect the message.
- If the Print Adjust screen is used to change certain Properties.

## Acknowledgement Complete

Acknowledgement Complete will transmit to an external computer that a print buffer has completed printing. This Acknowledgement has an option to transmit a single character “C,” or to transmit the text from every field in the message. The “C” is transmitted by itself; the field data will end with a <CR>.

The field data is transmitted as comma-delimited fields, plus two additional fields for date and time stamps. This data can be placed into a log as a record of every message printed. The field data is built up as the fields are processed in the message; the fields will appear in the order that they were added to the message, not in the order that they appear in the message.

## Acknowledgement Photocell

The Acknowledgement Photocell will transmit to an external computer whenever the Photocell Trigger is sensed. This Acknowledgement will transmit a single character “P.”

The Acknowledgement Photocell will be transmitted at every Photocell Trigger, whether the Jet is on or off, and whether the Printer is ready to print or not.

## Web Browser Utility

The 5000 Series printer uses the web browser as a method to update the printer’s firmware, perform Backup and Restore, download graphics, fonts and language files without the need of other programs.

Using the printer’s Ethernet connection port on the CPU board for this process. A standard Ethernet cable can be used when connecting thru a hub, switch, or router. An Ethernet Crossover Cable must be used when connecting directly from a computer to the printer.

Open a web browser and type in the IP address assigned and entered into the printer. (example <http://192.168.1.250>)

The browser will display a dropdown menu (as shown below)

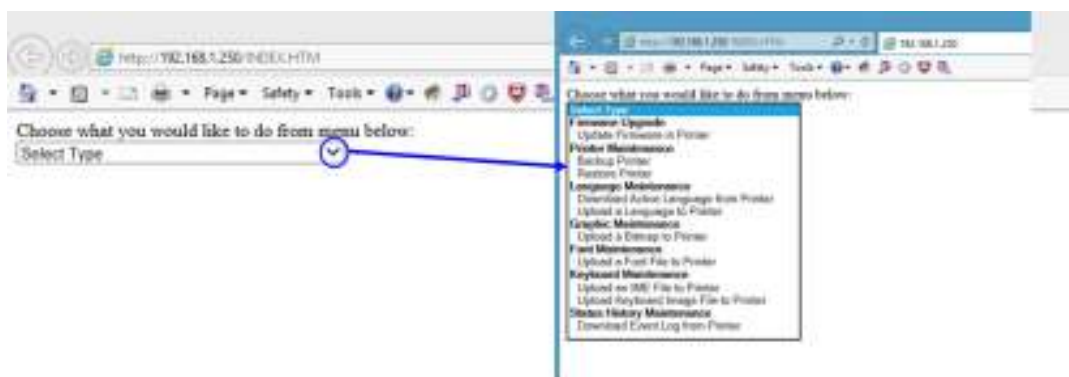

## Firmware Upgrade

To upgrade the firmware, simply click on the “Update Firmware in Printer” from the dropdown menu.



The page below will open. Click the “Browse...” button and navigate to the location you have the firmware store on the computer.

Choose what you would like to do from menu below:

File to process:  v101q05\_APP.s19  
 Reboot after programming  
 Update Date/Time  
 ←

Curent System Date/Time:

**Note:** *the firmware selected will be displayed.*

Ensure the “Reboot after programming” box is checked. If the time need to be updated, check the box for “Update Date/Time”. Then click “Send File”.

**Note:** this process can take several minutes. Do not select the Back Button

The Printer will reboot and the browser screen will display the following when the printer has been successfully reprogrammed.

Found first record  
File platforms match  
Beginning to process application file  
Processing  
Processing  
Processing  
Processing  
Writing Firmware

File update complete  
Printer will complete reboot in 45 seconds  
To load the main web page click [here](#) after printer reboots

## Backup

Clicking on the Backup Printer from the dropdown menu will open a separate window displaying the Backup file data as shown below.

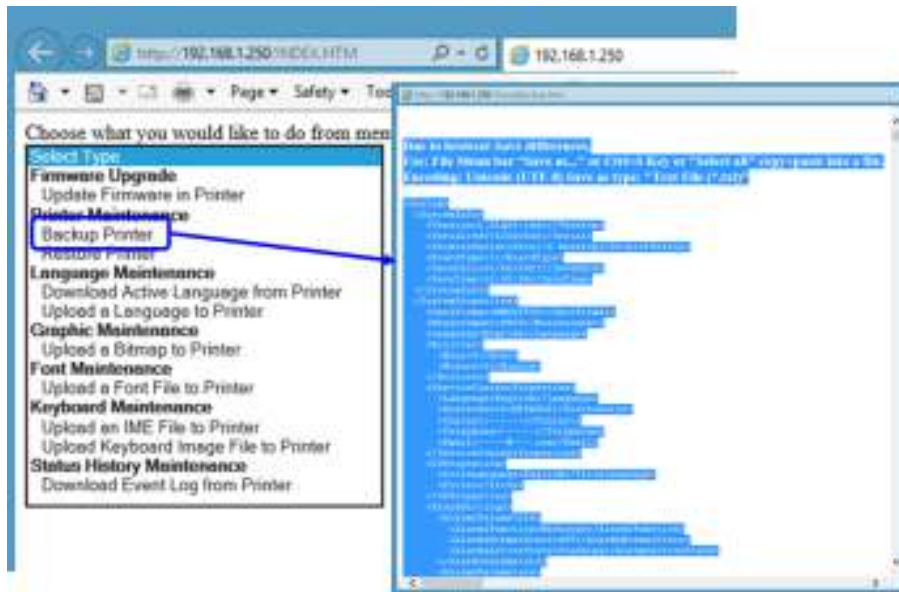

Due to the differences in the way browsers save, make sure to use: File Menu bar "Save as..." or Ctrl+S Key or "Select all" then copy and paste into a file. The file must be saved with Save as type: "Text File (\*.txt)" file Encoding: Unicode (UTF-8).



Highlight and copy all:

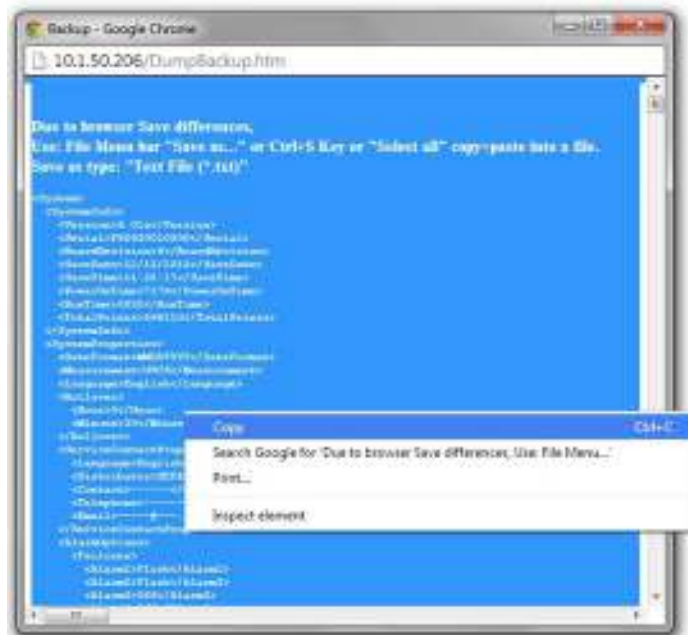

After highlighting the information, scroll down to the bottom of the highlighted file and verify that the highlighted area includes `</Graphics>` as the last tag of the last line. This ensures that all of the data has been captured before copy and paste.

Paste the text in Notepad and save as a .txt file. Name the file as the Printer, line, or serial number so you will know which Printer it was from.

**NOTE:** When saving a backup file, it is **IMPORTANT** to note the encoding must be UTF-8 (see picture below). The restore file must be encoded UTF-8. If it is not saved this way, Unicode characters (example: Chinese, Japanese, etc.) will not restore correctly.

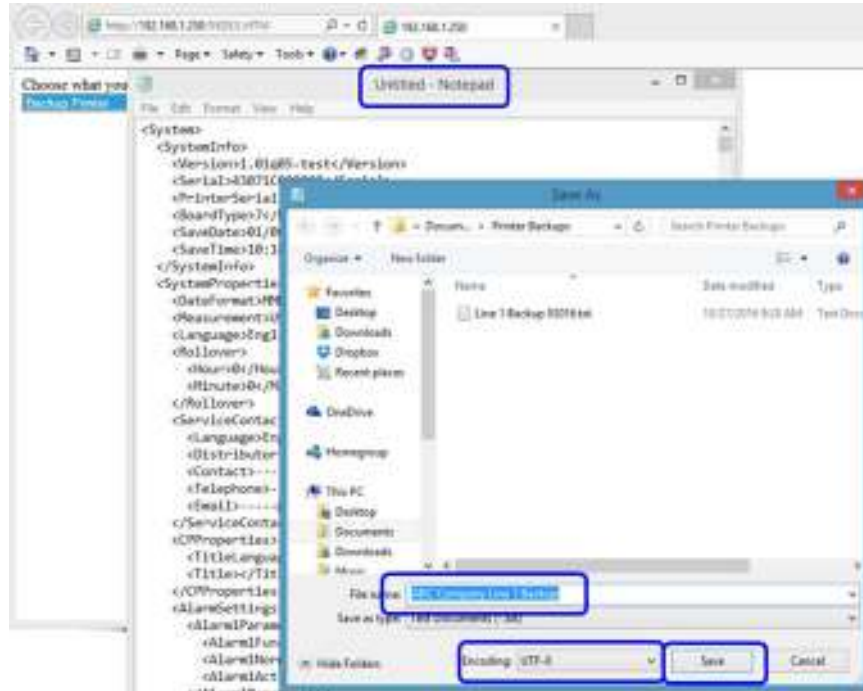

## Restore

In this option, you can use a Backup file to restore any corrupt data on a Printer. If a Backup file is used on the same CPU board, all the Message Settings, Message, Service Setting, etc. will be restored. If a Backup file is not used on the same CPU board, all non-hardware settings will be restored. This can be used to “clone” Printers.

To restore a Printer:

Click on “Restore Printer” and the screen will display as below:

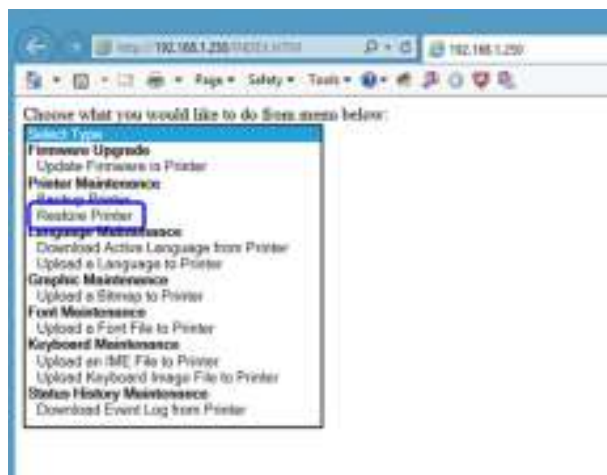

Click the “Browse...” button and navigate to the location you have saved the Backup file you are using to restore. Select the file and press “Open.”

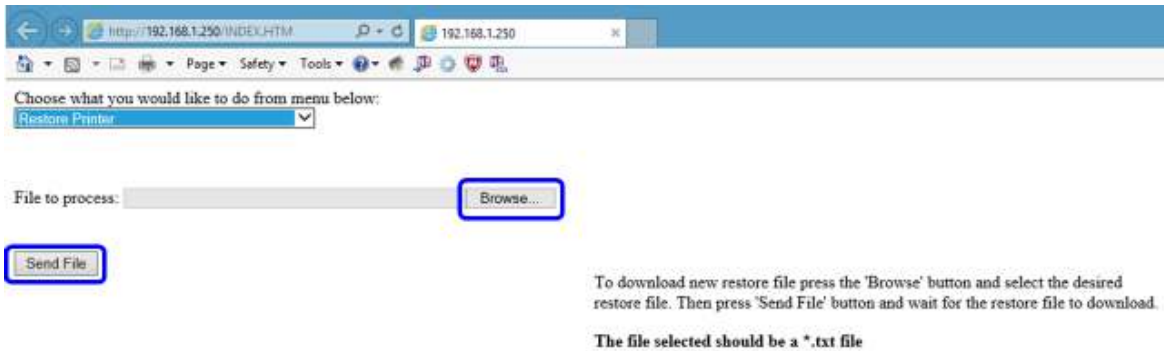

During the Restore process the printer will indicate a Restore is in progress.



When the restore is complete the Web Browser will display the following and the Printer screen will return to the Home screen.

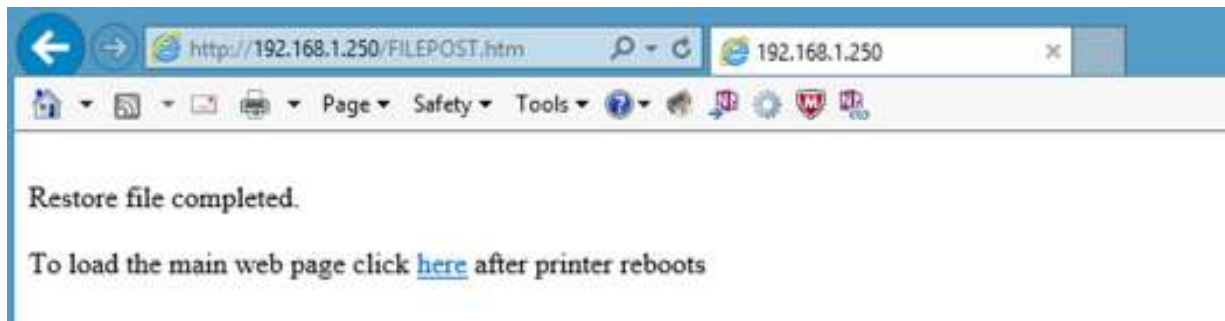

## SECTION 8: SPARES & ACCESSORIES

### Contents



	Page
Cabinet.....	8-2
Electronics .....	8-2
Hydraulics .....	8-4
Printhead .....	8-10
Spares & Tools.....	8-16
Consumables.....	8-16
Level 1 (End Users) Spares .....	8-17
Level 2 (Service Engineers) Spares.....	8-18
Tools.....	8-18
Options and Accessories.....	8-19
Photocell / Encoder.....	8-19
Alarm Beacons .....	8-21
Stands & Holders .....	8-21

## Cabinet

### Electronics

Image	Part Number Description
	110-0018-001 PCB, CPU Tested (Rev5) <i>Specify machine type when ordering</i>
	004-1005-001 Power Switch Assembly
	004-1108-001 IEC/EMI Power Plug
	002-2018-001 Front Tablet with touchscreen, Stainless
	004-2019-001 Front Tablet with touchscreen, Black

	<p>022-2003-001 Cable Assy, Encoder (3 pin)</p>
	<p>022-2004-001 Cable Assy, Photocell (4 pin)</p>
	<p>022-2005-001 Cable Assy, Beaconl (7 pin)</p>
	<p><b>022-1057-001</b> Power Cord, India <b>022-1058-001</b> Power Cord, USA <b>022-1059-001</b> Power Cord, China <b>022-1060-001</b> Power Cord, EURO <b>022-1061-001</b> Power Cord, UK</p>
	<p><b>022-1022-001</b> Cable Assy, Level Detect</p>

	<p><b>004-1001-003</b> Fan, Cooling</p>
	<p><b>004-1028-001</b> Guard, Fan</p>
	<p><b>004-1047-004</b> Cover, Air Filter</p>
	<p><b>004-1002-001</b> PSU, High Voltage</p>
	<p><b>004-1029-001</b> Power Supply, DC</p>

## Hydraulics

Image	Part Number Description
-------	----------------------------

	<p><b>003-2055-001</b> Viscometer Assembly, <i>(specify ink type when ordering)</i></p>
	<p><b>003-1235-001</b> Adapter, Viscometer, 6mm to 1/4inch</p>
	<p><b>003-1228-001</b> Viscometer Bracket</p>
	<p><b>003-1231-001</b> Strap, Viscometer</p>
	<p><b>003-1229-001</b> Service Module Base Unit</p>
	<p><b>003-1233-001</b> Service Module Bracket</p>

	<p><b>003-1243-001</b> Fitting, Union Elbow, 0.25OD</p>
	<p><b>003-1244-001</b> Ferrule, Flangeless 1/8in yellow</p>
	<p><b>003-1245-001</b> Nut, Flangeless Polypropylene 1/8in</p>
	<p><b>003-1246-001</b> Feed Damper</p>
	<p><b>003-2060-001</b> Printer Service Kit, ci5000, 8,000 hours</p> <p>Includes:</p> <ul style="list-style-type: none"><li>- 1 x 003-1230-001</li><li>- 1 x 004-1015-003</li></ul>

	<p><b>003-1230-001</b> Service Module ci5000</p>
	<p><b>003-1005-001</b> Pump, Head</p>
	<p><b>003-1155-001</b> Pump, Head Heavy Pigment (Only for Heavy Pigment Printer)</p>
	<p><b>003-1006-001</b> Pump, Motor</p>
	<p><b>003-2047-001</b> Restrictor, Kit</p>

	<p><b>003-1202-001</b> Fitting, 90 degree push to connect</p>
	<p><b>003-1190-001</b> Cap, Ink Fill (Black)</p>
	<p><b>003-1191-001</b> Cap, Makeup Fill (Yellow)</p>
	<p><b>003-1023-001</b> Valve, Ink Manifold 2 Way</p>
	<p><b>003-1024-001</b> Valve, Ink Manifold 3 Way</p>

	<p><b>003-1199-001</b> Fitting, 0.125 push to connect</p>
	<p><b>003-1200-001</b> Fitting, .25, push to connect</p>
	<p><b>003-1201-001</b> Fitting, .375, push to connect</p>
	<p><b>003-1042-002</b> O-ring, Pressure Transducer</p>
	<p><b>003-1020-002</b> Pressure Transducer</p>

	<p><b>003-2051-001</b> Assembly, Ink Tank Manifold</p>
	<p><b>003-2050-001</b> Assembly, Makeup Tank Manifold</p>
	<p><b>003-1014-002</b> Tank, Ink</p>
	<p><b>003-1014-003</b> Tank, Makeup</p>
	<p><b>019-1088-001</b> Screw, hex head, SS 2.75in (holds down ink tank)</p>

**Printhead**

Image	Part Number Description
-------	----------------------------

	<p><b>002-1002-004</b> Bracket, Drop Generator 2003-2006</p> <p><b>002-1002-005</b> Bracket, Drop Generator 2007</p> <p><b>002-1002-006</b> Bracket, Drop Generator 2008</p>
	<p><b>002-1008-006</b> Electrode, Charge</p>
	<p><b>002-1073-002</b> PCB, Phase Amplifier/Sensor Assy</p>
	<p><b>002-2012-002</b> Cover, Printhead Front</p>
	<p><b>002-1011-004</b> Cover, Printhead Back</p>

	<p><b>002-1012-003</b>  <b>Plate, Deflector GND</b></p> <p><b>002-1091-001</b>  <b>Plate, Deflector GND (Micro Only)</b></p>
	<p><b>002-2005-002</b>  <b>Assy, Deflector Plate Angled+</b></p> <p><b>002-2022-001</b>  <b>Assy, Deflector Plate (Micro Only)</b></p>
	<p><b>019-1501-001</b>  <b>Screw, Thumb Printhead 2007</b></p>
	<p><b>002-2025-002</b>  <b>Nozzle, Plate 65 2008</b></p> <p><b>002-2026-002</b>  <b>Nozzle, Plate 40 2008 (Micro Only)</b></p> <p><b>002-2027-002</b>  <b>Nozzle, Plate 50 2008 (HS50 Only)</b></p>
	<p><b>002-2013-002</b>  <b>Assy, Resonator Probe with o-ring, 2013</b></p>

	<p><b>002-1017-001</b> <b>Fitting, Gutter, Barb</b></p>
	<p><b>002-1013-003</b> <b>Block, Gutter</b></p>
	<p><b>002-2007-001</b> <b>Sensor, Gutter</b></p>
	<p><b>002-1098-001</b> <b>Connector, IDC Printhead Wires</b></p>
	<p><b>002-1118-002</b> <b>Cam, Jet Alignment 2008</b></p>

	<p><b>003-1025-001</b> <b>Valve, Printhead</b></p>
	<p><b>002-1003-003</b> <b>Manifold, Printhead Valve</b></p>
	<p><b>002-1029-001</b> <b>Gasket, Printhead Valve</b></p>
	<p><b>002-2008-002</b> <b>Assy, Strobe Block</b></p>
	<p><b>002-2008-003</b> <b>Assy, Strobe Block (Micro Only)</b></p>

	<p><b>002-2014-003</b>  <b>Drop Generator Block, Hybrid</b></p>
	<p><b>002-2002-001</b>  <b>Assy, Drop Generator 2003-2007</b>                  Only for sale with ci580, ci700, ci1000, ci2000 (Printer sold between 2003 – 2007)</p> <p><b>002-2002-003</b>  <b>Assy, Drop Generator 2008 (nozzle and calibration included)</b></p>
	<p><b>002-1100-003</b>  <b>O-Ring, Resonator Probe 2008</b></p>
	<p><b>002-2009-001</b>  <b>Assembly, Lid Switch</b></p>
	<p><b>002-2024-001</b>  <b>HV Resistor, Kit Printhead (includes resistor, heat shrink)</b></p>

	<p><b>002-1033-001</b>  <b>Contact, Solder Charge Cable</b></p>
	<p><b>004-1012-001</b>  <b>Connector, Conduit Straight</b></p>
	<p><b>004-1070-001</b>  <b>Connector, Conduit 90 Degree</b></p>

## Spares & Tools

### Consumables

Image	Part Number Description
	<p><b>016-6009-001</b>  <b>Hand Cleaner, Reduran</b></p>

	<b>016-6013-001</b> <b>Wipes, Blue Shop Paper Roll</b>
	<b>014-1041-001</b> <b>Funnel, Filling Clean Solution</b>
	<b>016-6014-001</b> <b>Cleaner, Stainless Steel</b>
	<b>016-1016-001</b> <b>Solution, Nozzle Cleaning, 4 oz.(Phetch)</b>

### Level 1 (End Users) Spares

Spares recommended for end users are as follows:



Part Number	Description	Quantity
004-1059-001	Fuse, Mains 5x20 3.15amp	2
004-1061-001	Battery, 3V Backup Lithium	1
002-1083-003	Nozzle, Printhead 65 2003-2007	1
003-1230-001	Service Module ci5000	1
004-1015-003	Filter, Air	1

## Level 2 (Service Engineers) Spares

Part Number	Description	Quantity
100-0011-004a	PCB, CPU Tested (Rev 4) **Specify machine type at ordering	1
004-1002-001	PSU, High Voltage	1
004-1029-001	Power Supply, DC	1
004-1001-003	Fan, Cooling	1
004-2012-002	Display Assy, w/ LED Backlight, Qtr VGA	1
003-1005-001	Pump, Head	1
003-1006-001	Pump, Motor	1
003-1023-001	Valve, Ink Manifold 2 Way	1
003-1024-001	Valve, Ink Manifold 3 Way	1
002-1073-002	PCB, Phase Amp/Sensor Assy	1
003-1025-001	Valve, PH 3 way	1
002-2002-003	Assy, Drop Generator 2008	1
002-1012-003	Plate, Deflector GND	1
002-2005-002	Assy, Deflector Plate Angled +	1
014-1032-001	Loupe, Eye Piece	1
014-1051-001	Wrench, Allen Key 1/16 inch	1
014-1078-001	Wrench, Allen Key 1/32 inch	1
014-1067-001	Wrench, Allen Key 3/16 inch	1
014-1066-001	Wrench, Allen Key 5/32 inch	1
014-1074-001	Screwdriver, Slotted 1/8 inch	1
014-1075-001	Screwdriver, Phillips #0	1
014-1080-001	Cutter, Side Cutters	1
014-1052-001	Cutter, Tubing	1
014-1076-001	Flashlight, Service	1
014-1040-001	Pliers, Flat Nose	1
014-1085-001	Wrist Strap, ESD	1

## Tools

Image	Part Number Description
-------	----------------------------

	<p><b>014-2001-005</b>          Kit, ciSeries, Specialized Tool          Included specialty tools:</p> <ul style="list-style-type: none"> <li>- 014-1032-001 Loupe, Eye Piece</li> <li>- 014-1051-001 Wrench, Allen Key 1/16 inch</li> <li>- 014-1078-001 Wrench, Allen Key 1/32 inch</li> <li>- 014-1067-001 Wrench, Allen Key 3/16 inch</li> <li>- 014-1066-001 Wrench, Allen Key 5/32 inch</li> <li>- 014-1074-001 Screwdriver, Slotted 1/8 inch</li> <li>- 014-1075-001 Screwdriver, Phillips # 0</li> <li>- 014-1080-001 Cutter, Side Cutters</li> <li>- 014-1052-001 Cutter, Tubing</li> <li>- 014-1076-001 Flashlight, Service</li> <li>- 014-1040-001 Pliers, Flat Nose</li> <li>- 014-1085-001 Wrist Strap, ESD</li> </ul>
	<p><b>014-1012-001</b>          Squirt Bottle, MEK Wash</p> <p><b>014-1013-001</b>          Squirt Bottle, Ethanol/Food Grade Wash</p> <p><b>014-1081-001</b>          Squirt Bottle, Acetone Wash</p>

**NOTE:** Tools can be sold separately using the part numbers listed in column 2

## Options and Accessories



### Photocell / Encoder

Image	Part Number Description
	<p><b>015-2020-001</b>          Photocell, Fiber Optic Proximity Diffuse (IP65 Connector)</p>

	<p><b>015-2021-001</b> Photocell, Fiber Optic Through Beam Opposing (IP65 Connector)</p>
	<p><b>015-2022-001</b> Photocell, Proximity Diffuse (IP65 Connector) Includes</p> <ul style="list-style-type: none"> <li>- Banner N6/IP67</li> <li>- 15ft (4.5M) Cable</li> <li>- Bracket &amp; screws</li> <li>- NPN Open Collector Output</li> </ul>
	<p><b>015-2023-001</b> Photocell, Retroreflective (IP65 Connector) Includes</p> <ul style="list-style-type: none"> <li>- Banner N6/IP67</li> <li>- 15ft (4.5M) Cable</li> <li>- Bracket &amp; screws</li> <li>- NPN Open Collector Output</li> <li>- LED Status Indicator</li> </ul>
	<p><b>015-2024-001</b> Cable, Photocell (IP65 Connector)</p>
	<p><b>015-2006-003</b> Encoder Kit, Shaft (IP65 Connector) Includes:</p> <ul style="list-style-type: none"> <li>- 9ft (3M) Cable</li> <li>- IP65</li> <li>- Spring Bracket</li> </ul>
	<p><b>020-1083-001</b> Connector, External 3-pin male, encoder <b>020-1085-001</b> Connector, External 4-pin male, photocell <b>020-1087-001</b> Connector, External 7-pin male, beacon</p>

--	--





### Alarm Beacons





Image	Part Number Description
	<p>015-2026-001 Beacon, Alarm, Single Stage (IP65 Connector)</p> <p>Includes:</p> <ul style="list-style-type: none"> <li>- Warning light(s)</li> <li>- 9ft (3M) Cable</li> <li>- Stand Mount Kit</li> </ul>
	<p>015-2027-001 Beacon, Alarm Dual Stage (IP65 Connector)</p> <p>Includes:</p> <ul style="list-style-type: none"> <li>- Warning light(s)</li> <li>- 9ft (3M) Cable</li> <li>- Stand Mount Kit</li> </ul>
	<p>015-2011-003 Beacon, Alarm 3 Stage (IP65 Connector)</p> <p>Includes:</p> <ul style="list-style-type: none"> <li>- Warning light(s)</li> <li>- 9ft (3M) Cable</li> <li>- Stand Mount Kit</li> </ul>

### Stands & Holders

Image	Part Number Description
-------	----------------------------

	<p><b>005-2008-003</b> Mounting Kit, Printhead Floor</p>
	<p><b>005-2010-003</b> Mounting Kit, Conveyor Side</p>
	<p><b>005-1044-001</b> Bracket, Cap 2" Post</p>
	<p><b>005-1081-002</b> Bracket, Printhead Clamp</p>
	<p><b>005-1082-001</b> Bracket, Photocell Mount</p>

	<p><b>005-1080-001</b> Bracket, Crossblock 2" x .5"</p>
	<p><b>005-1026-001</b> Bracket, Flange 2"</p>
	<p><b>005-1083-001</b> Bracket, Rod Cross Arm, Printhead</p>
	<p><b>005-1506-001</b> End Cap, Printhead Arm</p>
	<p><b>005-1502-001</b> Bracket, Rod Handle, 1" shaft</p>

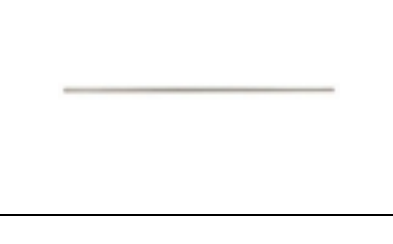
	<p><b>005-1503-001</b> Bracket, Printhead Handle, 1 9/16" shaft</p>
	<p><b>005-1075-001</b> Bracket, Alarm Beacon</p>
	<p><b>005-1028-001</b> Bracket, Leveling Feet</p>
	<p><b>005-1069-001</b> Bracket, Conveyor Mount 2"</p>
	<p><b>005-1027-001</b> Bracket, Post 2" x 5 FT</p>
	<p><b>005-1070-001</b> Bracket, Post 2" x 2 FT</p>



	<p><b>015-1021-002</b> Bracket, Fiber Optic</p>
---	---

Image	Part Number Description
	<p><b>022-1014-001</b> Cable, Shielded RS232 10 feet</p> <p><b>022-1015-001</b> Cable, Shielded RS232 25 feet</p> <p><b>022-1016-001</b> Cable, Shielded RS232 50 feet</p>
	<p><b>022-1017-001</b> Cable, Cat 5 Ethernet Patch 10 feet</p> <p><b>022-1018-001</b> Cable, Cat 5 Ethernet Patch 25 feet</p> <p><b>022-1019-001</b> Cable, Cat 5 Ethernet Patch 50 feet</p>

## SECTION 9: CALIBRATION

### CONTENTS

	Page
Calibration .....	9-2
Printhead Alignment.....	9-2
Band Adjustment (to be completed for each drop size) .....	9-7
Modulation Adjustment .....	9-9
Charge Adjustment .....	9-10

## Calibration

Calibration is needed to ensure the printer is printing at the most optimum level and print properly at any stage of operation.

Calibration includes 4 main parts. They are;

- Printhead alignment
- Band
- Modulation
- Charge level

A calibration needed whenever a part is changed on the printhead, like a Nozzle Plate, Resonator Probe, Drop Generator, and/or the Deflector Plate. It is also good practice to perform a Calibration after a Preventative Maintenance or whenever the print quality is not consistent. The following will be a guide to help any user to perform the correct Calibration process.

### Printhead Alignment





Proper printhead alignment starts from the bottom up.



1. Align the ink stream (jet) to the gutter. This is completed by the following;
  - Stop the Jet by pressing the [Jet Stop]  button. Allow the jet to complete the shutdown (Flush) procedure.

- Release the thumbscrew securing the Printhead front cover and slide off the cover. (as shown below)



- Press the [Menu Tab Bar]  and press the [Service]  button. Then press the [Override]  button in the Navigation Tool Bar. Select the Charge, Phase, and Gutter Fault overrides and then press the [Back]  button (as shown below). This will allow the ink stream (jet) to run while alignment be performed without disrupting the procedure with one of these faults.

**NOTE:** *At each power-off/on, the Overrides will default not selected.*



- Next place a beaker or paper towel underneath the printhead in case the jet misses the gutter and then press the [Jet Start]  button and observe the location of the Jet.
- Loosen the top securing screw shown in Fig 1 found on the back of the printhead chassis.



Fig 1

- Using the Adjustment (shown in Fig 2) adjust the horizontal alignment to 80% to the left of the gutter hole (shown in Fig 3). When the adjustment is complete tighten the securing screw



Fig 2

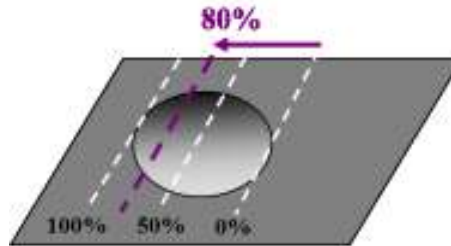

Fig 3

- Next loosen the top securing screw shown in Fig 4 found on the right side of the Drop Generator Mounting bracket.



Fig 4

- Using the Adjustment cam (shown in Fig 4) adjust the vertical alignment to center of the gutter hole (shown in Fig 5). When the adjustment is complete tighten the securing screw

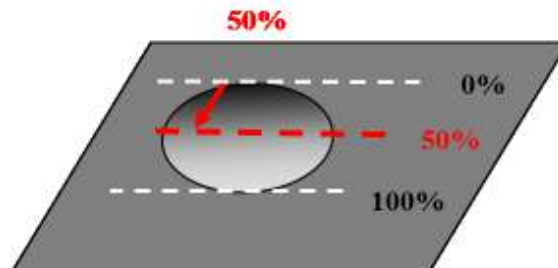
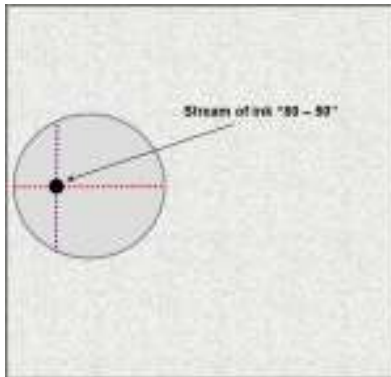
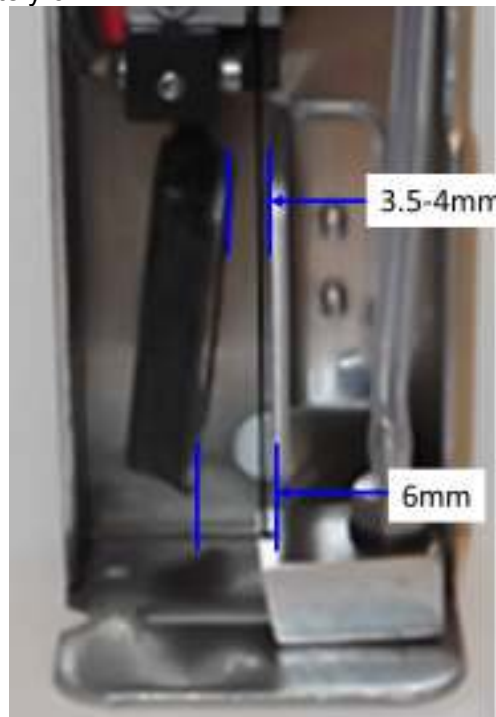

Fig 5

- The jet should now be in the proper position in the gutter block as seen below



2. Next align the Ground Deflector Plate so that it is parallel to the ink stream (shown in Fig 6)
3. Adjust the Positive HV Plate so that the distance between the plates are (shown in Fig 6)
  - o Top to 3.5 to 4mm
  - o Bottom is approximately 6mm



4. Adjust the Phase Detector until 100% Phase Quality is seen in the [Status] Screen
  - o Rule to use is align with left edge of Charge Electrode Slot

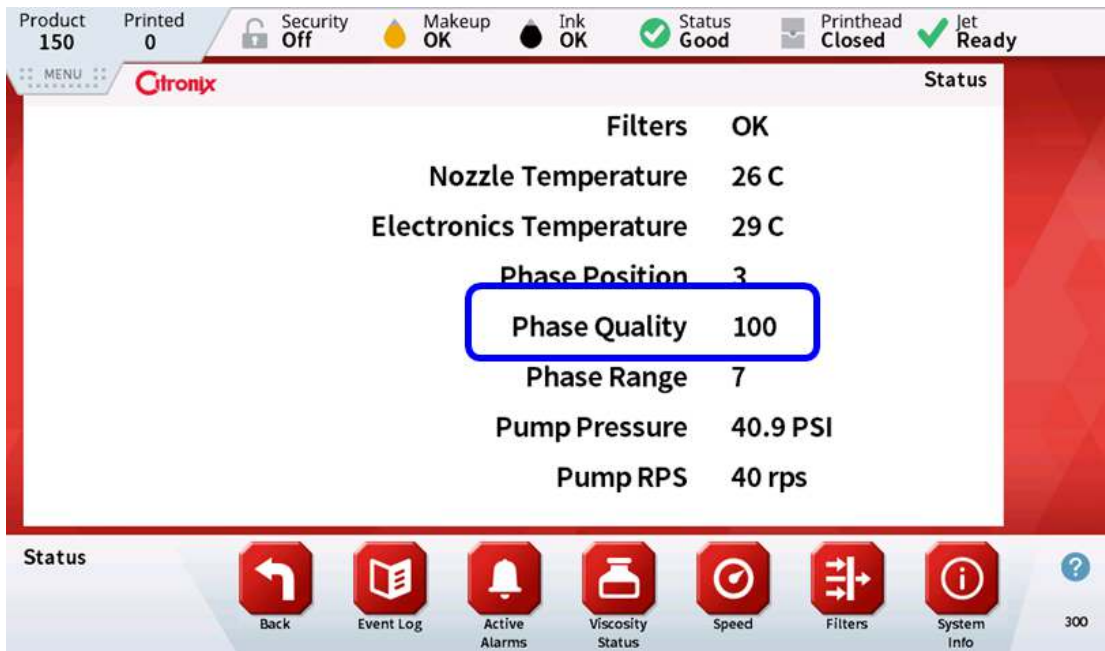
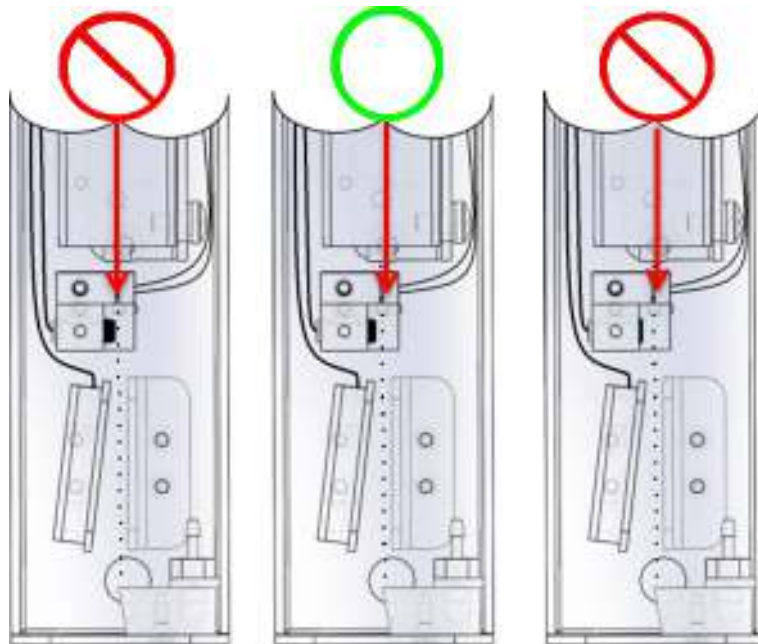

5. Align the Charge Electrode so that the ink stream is centered in the slot. This adjustment may be accomplished by first loosening the mounting screws and then gently levering the Charge Block using a screwdriver.



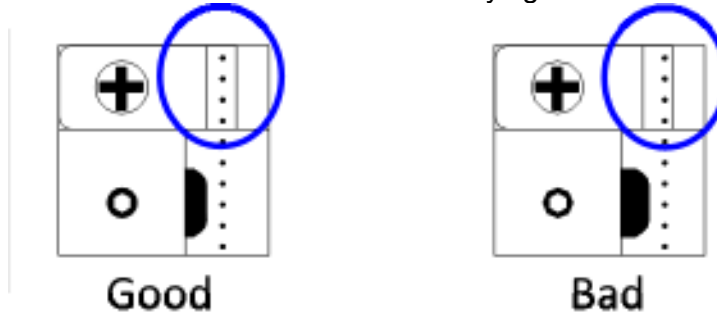

Use an eyeglass to confirm that the Jet is centered. Carefully tighten the securing screws.





### Band Adjustment (to be completed for each drop size)

Press the [Menu Tab Bar]  and press the [Service]  button.

1. Set the Charge to 72 by pressing the [Edit]  button and using the keypad enter 72 then press the [Save]  button.





2. Ensure or set the Pressure to 40psi by pressing the [Edit]  button to the right of Pressure. Using the keypad enter 40 and press the [Save]  button.

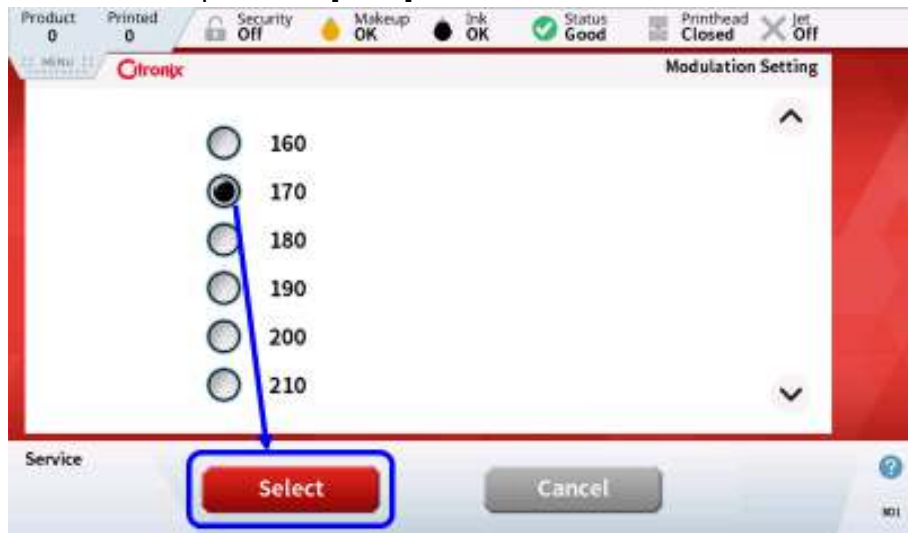

3. Set the Modulation to 170 by pressing the [Edit]  button to the right of Modulation. Select 170 from the list and press the [Save]  button.





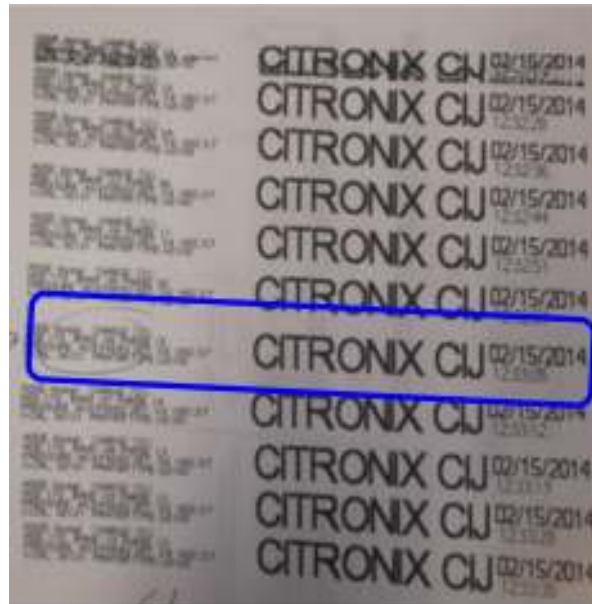

***NOTE:*** there are multiple screens. Use the up and down arrows to scroll thru the screens to find the setting.

4. Using the [Edit]  Button to the right of Band, select Band 0 from the list and press [Save] . Take a print sample by pressing the [Print Trigger]  button in the Function Tool Bar on the right edge of the screen. (The Bands range is from -10 to +10) Advance the Band by 1, wait 5 seconds, then take a print sample after each adjustment. (Use both + and -ranges).
- Inspect each sample at each Band setting for print defects and select the best print quality band to make your final set point.

***NOTE:*** Multiple good bands are possible to be found.



## Modulation Adjustment

1. Leave the Charge at 72 from the previous (Band) steps
2. Leave the Pressure at 40 from the previous (Band) steps
3. Using the [Edit]  button set the Band to new setting (found in the Band Adjustment sets)
4. Start at a Modulation of 240 by using the [Edit]  button to the right of Modulation and selecting from the list and pressing [Save] . Take a print sample as described in the previous step by pressing the [Print Trigger]  button in the Function Tool Bar. Advance the Modulation down to the next selection, wait 5 seconds, then take a print sample after each adjustment. Inspect each sample at each Modulation setting looking for print defects.  
***NOTE: A 100 volt window is the minimum acceptable range (example 240-140)***
5. If achieved, use the middle adjustment as the set point.
6. If not achieved, change the band setting (up or down) by 1 and retest.

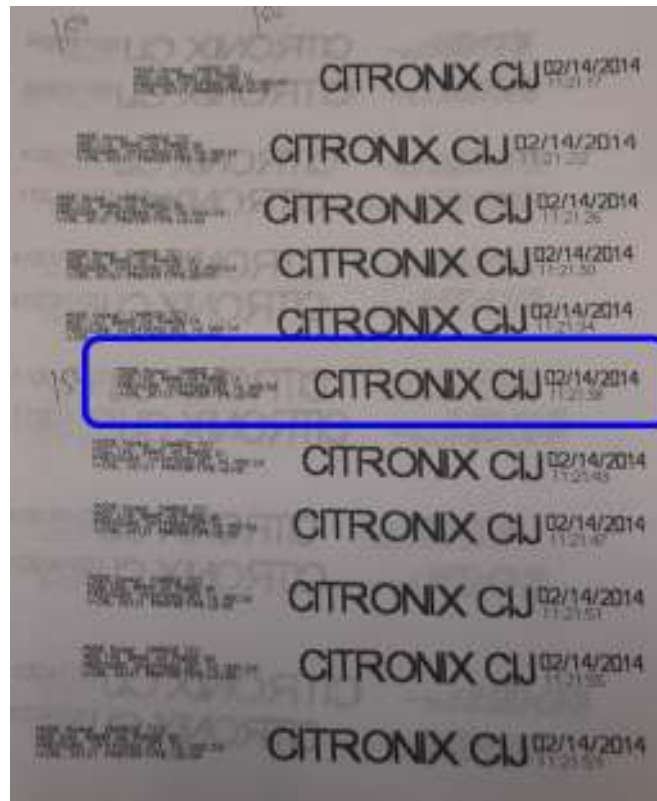

## Charge Adjustment

1. Leave the Charge at 72 from the 2 previous steps
2. Leave the Pressure at 40 from the 2 previous steps
3. Leave the Modulation at the new set point found in the previous step.
4. Set the Charge setting at 68, 72, & 76 by using the [Edit]  button as described in the first step, taking a print sample after each change.  
Inspect each sample at each Charge setting looking for print defects.  
The Charge setting is not fixed and if necessary, can be set to alternative levels.  
A 9% total Charge window is the acceptable scope range of this test
5. If achieved, use the middle adjustment as the set point
6. If not achieved, change slightly to achieve the desired range



**NOTE:** Pressure can also be adjusted slightly to allow for additional Print Quality. This should not be set outside 35-45psi for both normal and Macro drop sizes, 45-55 for HS50 and Micro drop sizes.

## SECTION 10: **ci5650 AIR SYSTEM**

### CONTENTS

	Page
ci5650 Air Handling System Overview .....	10-2
Principle of Operation .....	10-2
Components .....	10-3
Parts List.....	10-4

## **ci5650 Air Handling System Overview**

The Citronix ci5650 Continuous Ink Jet Printer is designed to IP65 rating for harsh (dusty) environments. This Printer utilizes plant air to cool and pressurize the Printer cabinet and to supply positive air to the Printhead.

### **Principle of Operation**

A factory air supply with a minimum of 25 psi (1.7 bar) air should be supplied to the air system mounted to the right-hand side of the ci3650 Printer. The air system will regulate the pressure to 15 psi (1 bar), separate out the moisture and filter the air.

Please note this is a manual adjustment and excessive air pressure will affect print quality due to air turbulence in the Printhead.

The clean/dry air is processed through the Printer to both the cabinet and the Printhead. The positive pressure within the Printer cabinet and Printhead prevents harmful dust or vapors from entering the Printer. An opening at the bottom of the hydraulic section of the cabinet allows the air to exhaust from the Printer. The positive air pressure prevents contaminants entering the cabinet and the air flow prevents the possibility of Ink vapor build-up.

Air is also used to provide clean dry air to the Printhead at 2.2 liters per minute (15 psi or 1 bar). This air is fed along the air line to the Printhead. An excessive air pressure will interfere with the Ink Jet and cause deterioration in print quality.

Before switching on power to the Printer:

1. Connect the factory air supply to the input Festo (or QCD) on the regulator (see Picture 1 in Section "Components" below).
2. Turn on the air supply and check that there are no leaks, then switch the Printer on.

The Printer can now be used.

## Components

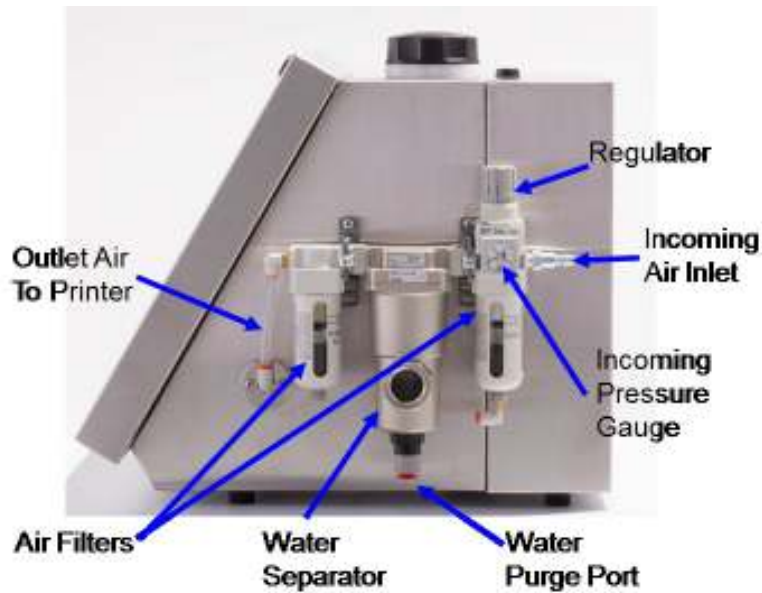

**Regulator/Filter Bowl System**

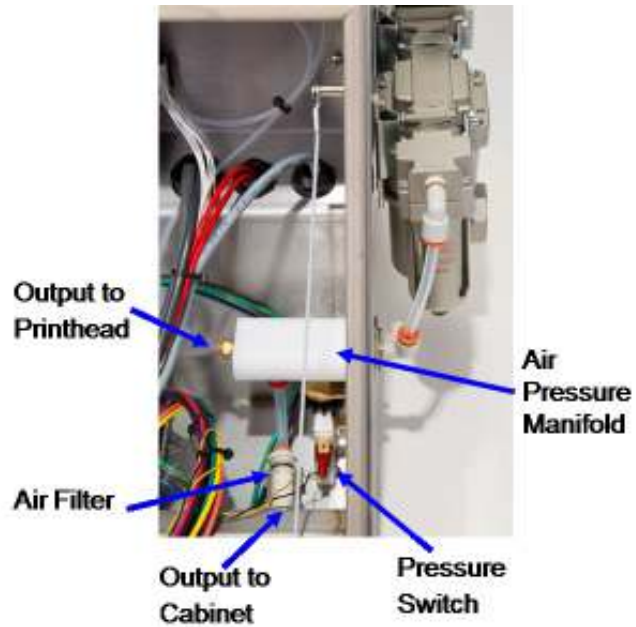

**Internal Components**

Pressure Switch plugs into the Fan connection (J25)



### Pressure Switch Connection

### Parts List

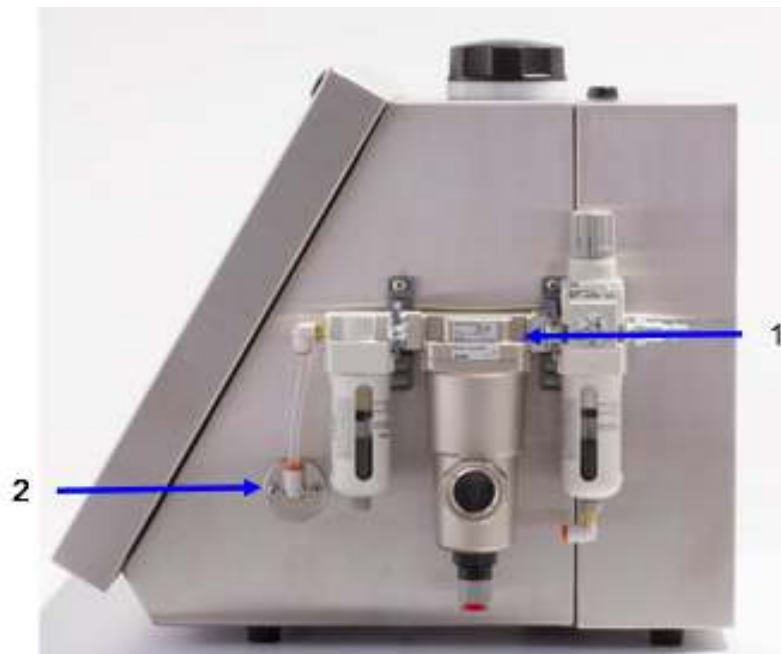

- |    |              |                                |
|----|--------------|--------------------------------|
| 1. | 004-1088-001 | Regulator/Filter Bowl Assembly |
| 2. | 004-1079-001 | Blanking Plate                 |

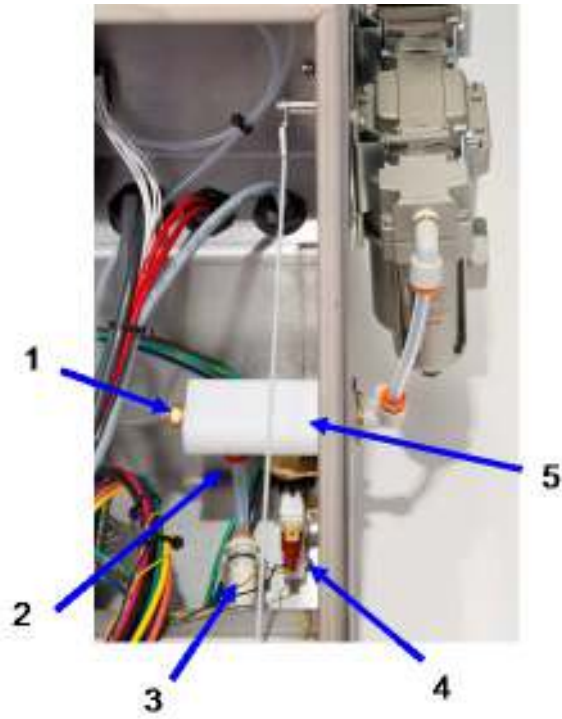

- |    |              |                     |
|----|--------------|---------------------|
| 1. | 004-1090-001 | 1/8" Tube fitting   |
| 2. | 004-1089-001 | 1/4" Tube fitting   |
| 3. | 004-1084-001 | Internal Air Filter |
| 4. | 004-1085-001 | Pressure Switch     |
| 5. | 004-1078-001 | Air Adapter         |

## SECTION 11: REFERENCE

### CONTENTS

	Page
Glossary Of Terms .....	11-2
Schematics .....	11-4
Display & Touch Connections .....	11-4
Electrical Connections .....	11-5
Fluids Connections .....	11-6
Menu Map .....	11-7

## Glossary Of Terms

Alphanumeric	Letter or number characters.
Attribute	A characteristic or distinctive feature.
Backlash	The ability to detect direction of line travel, enabling the print to be suspended when travelling in opposite direction and restart at the appropriate place.
BUJ	Break up point, below nozzle plate and within charge electrode, where jet breaks into drops.
CIJ	Continuous Ink Jet
Compact Flash	This is a memory card used to store vital printer information. It is located on the SBC.
DHCP	Dynamic Host Configuration Protocol. A protocol used to assign dynamic IP addresses on a dynamic network.
DNS	Domain Name System. This system converts domain names into IP addresses.
Drop	Ink drop. Also used as a unit of measurement in measuring character or font height.
Element	(Relating to Barcodes) Is any individual bar or space
Ethernet	This is the LAN (Local Area Network) technology used to connect the printer to other devices.
MSDS	Material Safety Data Sheet
PPR	Pulses Per Revolution. Number of pulses for 1 complete revolution of a shaft encoder.
Print Trigger	The internal trigger signal to initiate printing
Product Detect	The signal received from either an external device (product sensor) or internally, to start the printing process. i.e. if no delays or offsets are set, this will generate the print trigger signal immediately.
Range	Information presented by the printer - the range between which the value should appear.
Raster	The set of charge voltages that create a print stroke. Rasters are specifically designed to accommodate drop size characteristics, number of lines of print and the required print quality.

---

Select	Information to be put into the printer - use the keyboard <> keys to choose the option required. Then use the <i>Select</i> key to insert or open.
SDS	Safety Data Sheet
Shaft Encoder	A mechanical device that emits X amount of pulsed signals per revolution of the shaft. This is typically attached to a production line to ensure that the print width is kept constant to varying line speeds.
Sequencing	Application of an automatic sequence of actions, such as used to start up or shut down the printer.
Soft Key	Key having its function controlled by software. The key can, therefore, be expected to have different functions at different points in printer operation.
Status	Information presented by the printer - the current value, setting or adjustment in the printer.
Stroke	The adjacent lines of ink drops making up the character drop matrix. The distance between strokes is sometimes used as a unit of measurement in spacing or delays.
USB	Universal Serial Bus. This is defined as a “plug and play” device that can be fitted into the printer. In the ci5000 series printers a USB socket is provided to enable a USB mass storage device to be inserted, this can contain information that the printer can use to restore, or can be used to create back-ups etc.
Unicode	An international coding scheme for written characters and text, each of which is identified by a 16-bit code between 0000 and FFFF. The code conforms to a Standard maintained by the Unicode Consortium and ISO organization.
Web server	A Web server is a program that allows users to view information on the printer from a remote connection using a web browser such as Internet Explorer.

# Schematics

## Display & Touch Connections

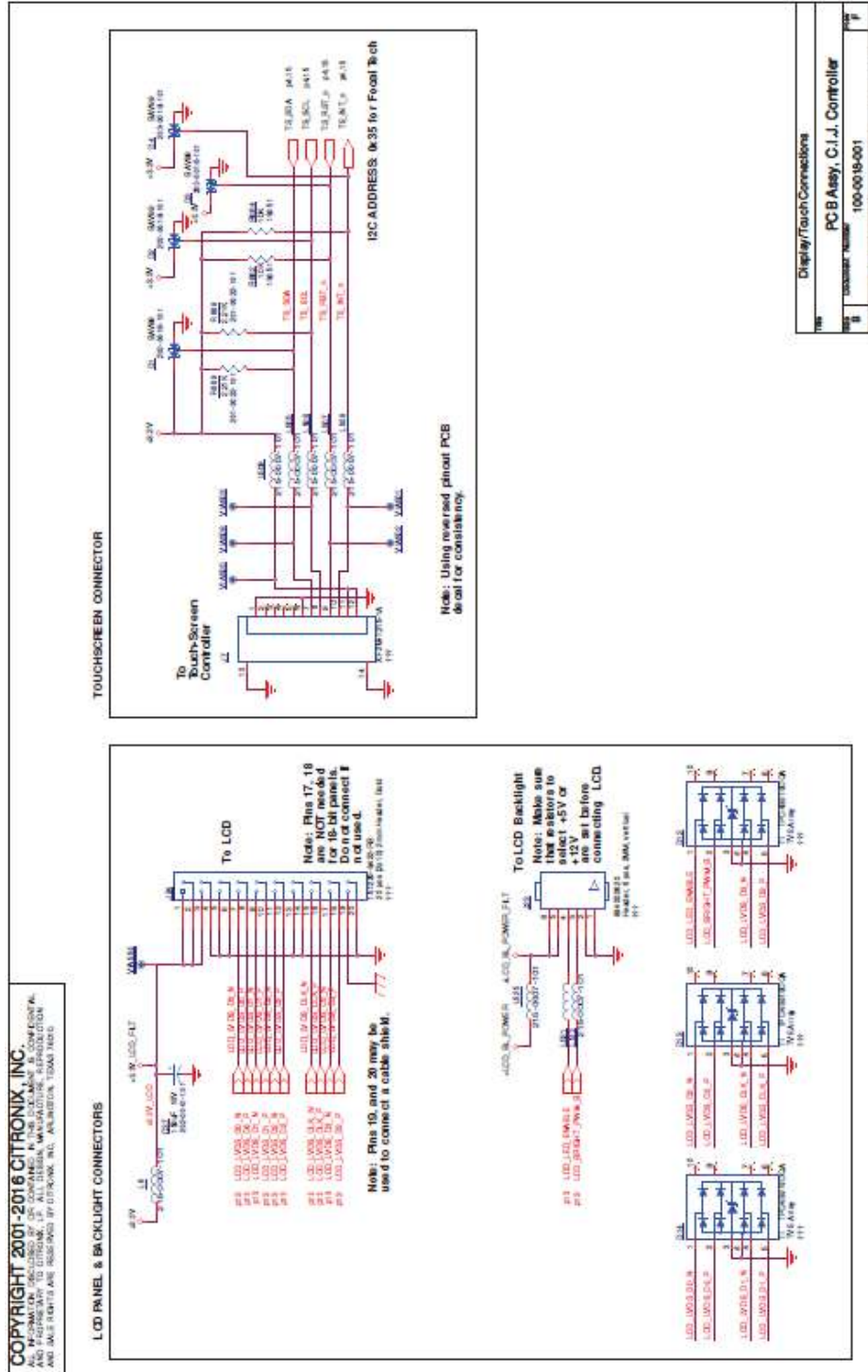



Fluids Connections

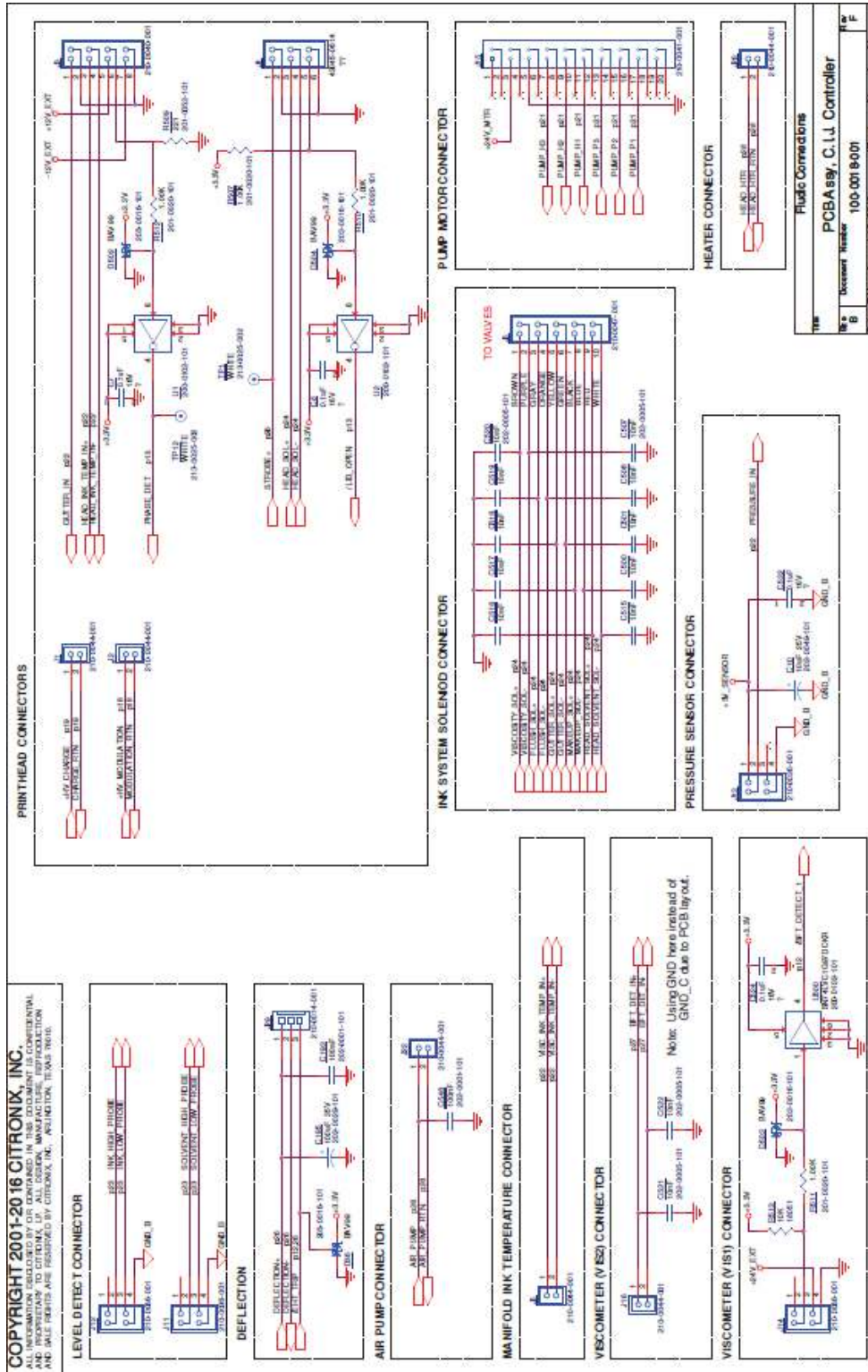

# Menu Map

